

**ALTERATION OF VASOMOTOR RESPONSES OF ARMS AND
LEGS BY EXERCISE STIMULATION IN AEROBIC AND
ANAEROBIC ATHLETES**



UNGSUMALIN PHUMCHAI

**A THESIS SUBMITTED IN PARTIAL FULFILLMENT
OF THE REQUIREMENTS FOR
THE DEGREE OF MASTER OF SCIENCE
(SPORTS SCIENCE)
FACULTY OF GRADUATE STUDIES
MAHIDOL UNIVERSITY
2004**

**ISBN 974-04-5235-3
COPYRIGHT OF MAHIDOL UNIVERSITY**

Thesis
Entitled

**ALTERATION OF VASOMOTOR RESPONSES OF ARMS AND
LEGS BY EXERCISE STIMULATION IN AEROBIC AND
ANAEROBIC ATHLETES**



Ungsumalin Phumchai

.....
Mrs. Ungsumalin Phumchai
Candidate

Thyon Chentanez

.....
Assoc.Prof.Thyon Chentanez,
Ph.D. (Neuroscience)
Major-Advisor

P. Kaimuk M.D.

.....
Assoc.Prof.Dr.Panya Kaimuk,
M.D. (Board of Orthopedic Surgery)
Co-Advisor

Thavorn Kamutsri

.....
Asst.Prof.Thavorn Kamutsri,
M.Sc. (Sports Science)
Co-Advisor

Rassmidara Hoonsawat

.....
Assoc.Prof.Rassmidara Hoonsawat,
Ph.D.
Dean
Faculty of Graduate Studies

P. Kaimuk M.D.

.....
Assoc.Prof.Dr.Panya Kaimuk,
M.D. (Board of Orthopedic Surgery)
Chairman
Master of Science Programme in
Sports Science
College of Sports Science and
Technology

Thesis
Entitled

**ALTERATION OF VASOMOTOR RESPONSES OF ARMS AND
LEGS BY EXERCISE STIMULATION IN AEROBIC AND
ANAEROBIC ATHLETES**

was submitted to the Faculty of Graduate Studies, Mahidol University
for the degree of Master of Science (Sports Science)

on
September 24, 2004



Mrs. Ungsumalin Phumchai
Candidate



Assoc.Prof.Thyon Chentanez,
Ph.D. (Neuroscience)
Chairman



Assoc.Prof.Dr.Panya Kaimuk,
M.D. (Board of Orthopedic Surgery)
Member



Asst.Prof.Wattana Jalayondeja,
Ph.D. (Ergonomics/Biomechanics)
Member



Asst.Prof.Thavorn Kamutsri,
M.Sc. (Sports Science)
Member



Assoc.Prof.Rassmidara Hoonsawat,
Ph.D.
Dean
Faculty of Graduate Studies
Mahidol University



Assoc.Prof.Dr.Panya Kaimuk,
M.D. (Board of Orthopedic Surgery)
Direction
College of Sports Science and Technology
Mahidol University

ACKNOWLEDGEMENTS

This dissertation would not have been successful without the kind assistance and extensive support from several mentors. First, I would like to express my deepest gratitude and sincere appreciation to my principal advisor, Assoc.Prof.Thyon Chentanez, for his guidance, excellent supervision, valuable advice, financial support and comment. My grateful appreciation is also extended to all of my co-advisors and the examination committee, Assoc.Prof.Dr.Panya Kaimuk, Asst.Prof.Thavorn Kamutsri, and Asst.Prof.Wattana Jalayondeja, for their kindness, extremely valuable advices, suggestions, and corrections of this dissertation

Special thanks for all volunteers who participated as a subject in this study, Mr.Pessayun Thipparos; Vice President of Student Council, Rajabhat Loei University ,Mr.Nopporn Keawmark; Dean of Education Faculty, Rajabhat Loei University ,Mr.Worapot Asarat; Head of Sports Science Program and Physical Education Program, Rajabhat Loei University and all the staff of Sports Science Program, Rajabhat Loei University, for their help in every way they could and support the subjects in this study. I would like to thank the Rajabhat Loei University for the permission to use the instruments and laboratory.

I am grateful to all the lecturers, staffs members and my friends from the Sports Science Program, College of Sports Science and Technology, Mahidol University for their support and inspiration.

Finally, I am extremely grateful to my parents, my husband and everybody in my family for their love, care, understanding, financial support, encouragement and mental support. I am equally grateful to Loei Hospital for giving the chance of my graduation.

Ungsumalin Phumchai

ALTERATION OF VASOMOTOR RESPONSES OF ARMS AND LEGS BY
EXERCISE STIMULATION IN AEROBIC AND ANAEROBIC ATHLETES

UNGSUMALIN PHUMCHAI 4537283 SPSS/M

M.Sc. (SPORTS SCIENCE)

THESIS ADVISORS: THYON CHENTANEZ Ph.D. (NEUROSCIENCE), PANYA
KAIMUK M.D. (ORTHOPEDIC SURGERY), THAVORN KAMUTSRI M.Sc.
(SPORTS SCIENCE)

ABSTRACT

The purpose of this study was to investigate vasomotor adaptations to 8 weeks prolonged aerobic and anaerobic exercise training. Investigation of changes in vasomotor responses to acute exercise stimulation of the arms and legs of trained aerobic, anaerobic and sedentary subjects were carried out. In addition, I studied changes in volume of the vasomotor when exercise stimulation was applied to upper and lower extremities by different exercises. An aerobic group, an anaerobic group and a control group consisting of sedentary people were on average aged 19-22 years old, weight about 50-78.2 Kg, and BMI from 18.33-28.65. The volume of changes in the vasomotor at different exercise situations was determined using a volumeter and the heart rate was also monitored. With an inflated blood pressure cuff on the left arm, there was no significant change in the heart rate and values of the left arm volume of the three groups of subjects. With an inflated blood pressure cuff on the right arm, the anaerobic group showed a significantly increased heart rate and values of the left arm volume compared to the control group. In pulling the pulley with the left hand with 15% MVC conditions, there was a significant increase in heart rate of the aerobic and anaerobic groups but there was no significant change in the values of the left arm volume for either group. In pulling the pulley with the right hand with 15% MVC conditions, there was a significant increase in heart rate of the anaerobic group but there was no significant change in the values of the left arm volume of either group. In Vo₂max test conditions, there was a significant increase in heart rate of the anaerobic and control groups but there was no significant change in the values of the upper and lower extremities volume at the same time. In Wingate test conditions, it was also found that the lower extremities of the aerobic group had a greater degree of vasodilatation than the control group. These results may suggest that aerobic athletes have greater stability of the vascular system in the leg than sedentary people. Explanations of these changes to the general public could suggest good exercise routines to lower blood pressure.

KEY WORDS: EXERCISE / VASODILATATION / VASOCONSTRICTION /
EXERCISE STIMULATION / VOLUMETER

143 pp. ISBN 974-04-5235-3

ผลของการออกกำลังกายระยะยาวต่อการเปลี่ยนแปลงของเส้นเลือดจากการใช้กล้ามเนื้อในระยะสั้น
(ALTERATION OF VASOMOTOR RESPONSES OF ARMS AND LEGS BY EXERCISE STIMULATION IN AEROBIC AND ANAEROBIC ATHLETES)

อังศุมาลิน ภูมิชัย 4537283 SPSS/M

วท.ม. (วิทยาศาสตร์การกีฬา)

คณะกรรมการควบคุมวิทยานิพนธ์: ไถ่ออน ชินธเนศ Ph.D. (Neuroscience), ปัญญา ไข่มุก M.D. (Orthopedic Surgery), ถาวร กมุตศรี M.Sc. (Sports Science)

บทคัดย่อ

การศึกษานี้มีวัตถุประสงค์เพื่อศึกษาผลของการออกกำลังกายระยะยาวต่อการเปลี่ยนแปลงขนาดของเส้นเลือดจากการใช้กล้ามเนื้อในระยะสั้นแบบต่างๆของแขนและขาในนักกีฬาที่ฝึกแบบใช้พลังงานแบบใช้ออกซิเจน, ไม่ใช้ออกซิเจน และผู้ไม่ออกกำลังกาย ทั้งสามกลุ่มมีอายุ (21.14 ± 0.77 , 20.79 ± 0.70 , 19.42 ± 0.52) น้ำหนัก (62.46 ± 7.70 , 61.84 ± 5.96 , 60.25 ± 6.78) และดัชนีมวลกาย (21.72 ± 2.36 , 21.04 ± 1.68 , 21.71 ± 2.92) ตามลำดับใกล้เคียงกัน โดยศึกษาการเปลี่ยนแปลงปริมาตรของแขนขาทั้ง 4 ปลายค์ โดยการกระตุ้นจากการใช้กล้ามเนื้อในระยะสั้นในแบบต่างๆด้วยวิธีการแทนที่ด้วยน้ำ เพื่อนำไปอธิบายถึงการเปลี่ยนแปลงของเส้นเลือด

ผลการศึกษาพบว่าการกระตุ้นแบบขัดขวางการไหลเวียนของเส้นเลือดในแขนซ้ายพบว่าทั้งอัตราการเต้นของหัวใจและปริมาตรของแขนซ้ายไม่แตกต่างกันมีนัยสำคัญทั้งสามกลุ่ม, ในการกระตุ้นแบบขัดขวางการไหลเวียนของเส้นเลือดในแขนขวาพบว่าในนักกีฬาที่ฝึกแบบใช้พลังงานแบบไม่ใช้ออกซิเจนมีการเพิ่มของอัตราการเต้นของหัวใจและปริมาตรของแขนซ้ายอย่างมีนัยสำคัญทางสถิติเมื่อเทียบกับกลุ่มที่ไม่ออกกำลังกาย, การกระตุ้นด้วยการดึงรอกด้วยมือซ้ายและมือขวาที่น้ำหนัก 15% ของน้ำหนักที่ยกได้สูงสุด และในการกระตุ้นด้วยการปั่นจักรยานเพื่อหาค่าการใช้ ออกซิเจนสูงสุด พบว่ามีอัตราการเต้นของหัวใจเพิ่มขึ้นอย่างมีนัยสำคัญทางสถิติในกลุ่มนักกีฬาที่ฝึกแบบใช้พลังงานแบบไม่ใช้ออกซิเจน แต่ปริมาตรของแขนซ้ายไม่แตกต่างกัน ในการทดลองปั่นจักรยานโดยใช้หลักการทดสอบการไม่ใช้ออกซิเจนพบว่านักกีฬาที่ฝึกแบบใช้พลังงานแบบใช้ออกซิเจนมีการขยายตัวของเส้นเลือดของขา มากกว่าผู้ไม่ออกกำลังกาย อย่างมีนัยสำคัญทางสถิติ ผลการศึกษานี้แสดงให้เห็นว่านักกีฬาที่ฝึกแบบใช้พลังงานแบบใช้ออกซิเจน (8 สัปดาห์) มีการพัฒนาการตอบสนองของเซลล์กล้ามเนื้อเรียบที่ควบคุมขนาดเส้นเลือดต่อระบบประสาทอัตโนมัติไม่ต่างไปจากนักกีฬาที่ฝึกแบบใช้พลังงานแบบไม่ใช้ออกซิเจน (8 สัปดาห์) ขณะเดียวกันค่อนข้างต่างไปจากผู้ไม่ออกกำลังกาย นักกีฬาที่ฝึกแบบใช้พลังงานแบบใช้ออกซิเจนมีการพัฒนาทางระบบหลอดเลือดที่มีคุณสมบัติค่อนข้างดีกว่านักกีฬาที่ใช้พลังงานแบบไม่ใช้ออกซิเจน

143 หน้า ISBN 974-04-5235-3

CONTENTS

	Page
ACKNOWLEDGEMENTS	iii
ABSTRACT	iv
LIST OF TABLES	vii
LIST OF FIGURES	ix
LIST OF ABBREVIATIONS	xiv
CHAPTER	
1 INTRODUCTION	1
2 LITERATURE REVIEW	
1. EXERCISE	4
2. AEROBIC TRAINING	7
3. ANAEROBIC TRAINING	13
4. VASOMOTOR	15
3 MATERIALS AND METHODS	25
4 RESULTS	34
5 DISCUSSION	67
6 CONCLUSION	78
REFERENCES	79
APPENDIX A	90
APPENDIX B	96
APPENDIX C	141
APPENDIX D	142
BIOGRAPHY	143

LIST OF TABLES

TABLE	PAGE
1. Characteristics of the three systems by which ATP is formed	5
2. General Characteristics of control subjects, aerobic athletes and anaerobic athletes used in this study	37
3. Arm volume of individual subject in control group	96
4. Arm volume of individual subject in control group	97
5. Arm volume of individual subject in control group	98
6. Arm volume of individual subject in control group	99
7. Leg volume of individual subject in control group	100
8. Leg volume of individual subject in control group	101
9. Arm volume of individual subject in aerobic group	102
10. Arm volume of individual subject in aerobic group	103
11. Arm volume of individual subject in aerobic group	104
12. Arm volume of individual subject in aerobic group	105
13. Leg volume of individual subject in aerobic group	106
14. Leg volume of individual subject in aerobic group	107
15. Arm volume of individual subject in anaerobic group	108
16. Arm volume of individual subject in anaerobic group	109
17. Arm volume of individual subject in anaerobic group	110
18. Arm volume of individual subject in anaerobic group	111
19. Leg volume of individual subject in anaerobic group	112
20. Leg volume of individual subject in anaerobic group	113
21. Arm volume per body weight of individual subject in control group	114
22. Arm volume per body weight of individual subject in control group	115
23. Arm volume per body weight of individual subject in control group	116
24. Arm volume per body weight of individual subject in control group	117
25. Leg volume per body weight of individual subject in control group	118

LIST OF TABLES (CONTS.)

TABLE	PAGE
26. Leg volume per body weight of individual subject in control group	119
27. Arm volume per body weight of individual subject in aerobic group	120
28. Arm volume per body weight of individual subject in aerobic group	121
29. Arm volume per body weight of individual subject in aerobic group	122
30. Arm volume per body weight of individual subject in aerobic group	123
31. Leg volume per body weight of individual subject in aerobic group	124
32. Leg volume per body weight of individual subject in aerobic group	125
33. Arm volume per body weight of individual subject in anaerobic group	126
34. Arm volume per body weight of individual subject in anaerobic group	127
35. Arm volume per body weight of individual subject in anaerobic group	128
36. Arm volume per body weight of individual subject in anaerobic group	129
37. Leg volume per body weight of individual subject in anaerobic group	130
38. Leg volume per body weight of individual subject in anaerobic group	131
39. Heart rate of individual subject in control group	132
40. Heart rate of individual subject in control group	133
41. Heart rate of individual subject in control group	134
42. Heart rate of individual subject in aerobic group	135
43. Heart rate of individual subject in aerobic group	136
44. Heart rate of individual subject in aerobic group	137
45. Heart rate of individual subject in anaerobic group	138
46. Heart rate of individual subject in anaerobic group	139
47. Heart rate of individual subject in anaerobic group	140
48. Aeorbic and Anaerobic training Program	142

LIST OF FIGURES

FIGURE	PAGE
1. A Comparison of left arm volume per body weight and left arm pre and post volume per body weight in inflated blood pressure cuff at left upper arm condition	38
B Comparison of left arm percent volume change per body weight and left arm pre and post percent volume change per body weight in inflated blood pressure cuff at left upper arm condition	
2. A Comparison of left arm volume per body weight and left arm pre and post volume per body weight in inflated blood pressure cuff at right upper arm condition	39
B Comparison of left arm percent volume change per body weight and left arm pre and post percent volume change per body weight in inflated blood pressure cuff at right upper arm condition	
3. A Comparison of left arm volume per body weight and left arm pre and post volume per body weight in pull pulley left hand with resistance 15% maximal voluntary contraction(MVC)condition	40
B Comparison of left arm percent volume change per body weight and left arm pre and post percent volume change per body weight in pull pulley left hand with resistance 15% maximal voluntary contraction(MVC)condition	
4. A Comparison of left arm volume per body weight and left arm pre and post volume per body weight in pull pulley right hand with resistance 15% maximal voluntary contraction(MVC)condition	41
B Comparison of left arm percent volume change per body weight and left arm pre and post percent volume change per body weight in pull pulley right hand with resistance 15% maximal voluntary contraction(MVC)condition	

LIST OF FIGURES (CONTS.)

FIGURE	PAGE
5. A Comparison of left arm volume per body weight and left arm pre and post volume per body weight in VO ₂ max test (Astrand- rhyming test) condition	42
B Comparison of left arm percent volume change per body weight and left arm pre and post percent volume change per body weight in VO ₂ max test (Astrand- rhyming test) condition	
6. A Comparison of right arm volume per body weight and right arm pre and post volume per Body weight in VO ₂ max test (Astrand- rhyming test) condition	43
B Comparison of right arm percent volume change per body weight and right arm pre and post percent volume change per body wieght in VO ₂ max test (Astrand- rhyming test) condition	
7. A Comparison of left leg volume per body weight and left leg pre and post volume per body weight in VO ₂ max test (Astrand- rhyming test) condition	44
B Comparison of left leg percent volume change per body weight and left leg pre and post percent volume change per body weight in VO ₂ max test (Astrand- rhyming test) condition	
8. A Comparison of right leg volume per body weight and right leg pre and post volume per body weight in VO ₂ max test (Astrand- rhyming test) condition	45
B Comparison of right leg percent volume change per body weight and right leg pre and post percent volume change per body weight in VO ₂ max test (Astrand- rhyming test) condition	
9. A Comparison of left arm volume per body weight and left arm pre and post .olume per body weight in wingate test condition	46

LIST OF FIGURES (CONTS.)

FIGURE	PAGE
B Comparison of left arm percent volume change per body weight and left arm pre and post percent volume change per body weight in wingate test condition	
10. A Comparison of right arm volume per body weight and right arm pre and post volume per body weight in wingate test condition	47
B Comparison of right arm percent volume change per body weight and right arm pre and post percent volume change per body weight in wingate test condition	
11. A Comparison of left leg volume per body weight and left leg pre and post volume per body weight in wingate test condition	48
B Comparison of left leg percent volume change per body weight and left leg pre and post percent volume change per body weight in wingate test condition	
12. A Comparison of right leg volume per body weight and right leg pre and post volume per body weight in wingate test condition	49
B Comparison of right leg percent volume change per body weight and right leg pre and post percent volume change per body weight in wingate test condition	
13. A Comparison of heart rate and pre and post heart rate in inflated blood pressure cuff at left upper arm condition	58
B Comparison of percent change of HR and percent change of HR pre-post test in inflated blood pressure cuff at left upper arm condition	
14. A Comparison of heart rate and pre and post heart rate in inflated blood pressure cuff at right upper arm condition	59
B Comparison of percent change of heart rate and percent change of heart rate pre-post test in inflated blood pressure cuff at right upper arm condition	

LIST OF FIGURES (CONTS.)

FIGURE	PAGE
15. A Comparison of heart rate and pre and post heart rate in pull pulley left hand with resistance 15% maximal voluntary contraction (MVC) condition	60
B Comparison of percent change of heart rate and percent change of heart rate pre-post test in pull pulley left hand with resistance 15% maximal voluntary contraction (MVC) condition	
16. A Comparison of heart rate and pre and post heart rate in pull pulley right hand with resistance 15% maximal voluntary contraction (MVC) condition	61
B Comparison of percent change of heart rate and percent change of heart rate pre-post test in pull pulley right hand with resistance 15% maximal voluntary contraction (MVC) condition	
17. A Comparison of heart rate and pre and post heart rate in VO ₂ max test (Astrand- rhyming test) condition	62
B Comparison of percent change of heart rate and percent change of heart rate pre-post test in VO ₂ max test (Astrand- rhyming test) condition	
18. A Comparison of heart rate and pre and post heart rate in wingate test condition	63
B Comparison of percent change of heart rate and percent change of heart rate pre-post test in wingate test condition	
19. A Technical data of flow rate /20 sec, period = 120 sec, normal collection, H ₂ O 1000 ml = 992 g	95
B Technical data of flow rate /20 sec, period at 40 to 120 sec, normal collection, H ₂ O 1000 ml = 992 g	
20. Digital weight machine (AD-6201, Japan)	90
21. Skinfold Caliper (F-LSC, England)	90
22. Hand Grip and Back-Leg Dynamometer (Takei & Company, Japan)	91
23. Wingate test machine set	91

LIST OF FIGURES (CONTS.)

FIGURE	PAGE
24. Polar (F-PLC, Finland)	92
25. Sit and reach box (Sports Science Program, Rajabhat Loei University)	92
26. Volumeter (Biomedical Equipment technology, Mahidol University) side view	93
27. Volumeter (Biomedical Equipment technology, Mahidol University) front view	94

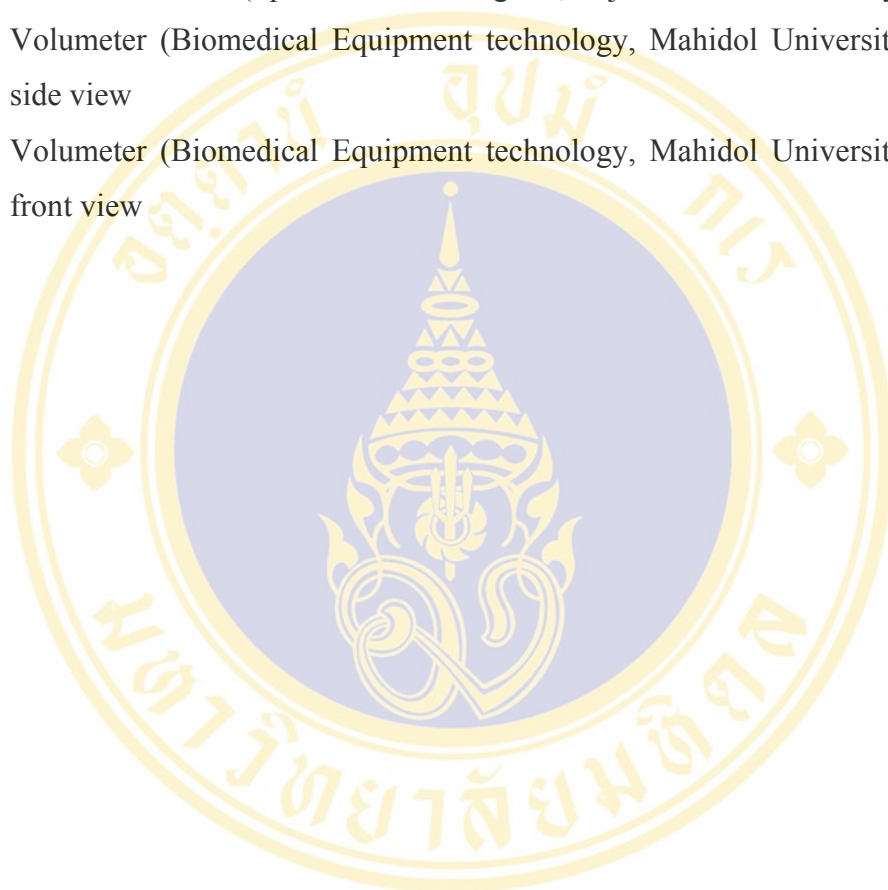

LIST OF ABBRIVIATIONS



BMI	body mass index
BW	body weight
cm	centimeters
HR	heart rate
Ht	body height
MVC	Maximum voluntary contraction
g	gram
Kg	Kilogram
l	liter
m	meter
max	maximum, maximal
min	minute
ml	milliliter
SD	standard deviation
sec	second
SEM	standard error of mean
yr	year

CHAPTER 1

INTRODUCTION

During exercise there is a redistribution of blood flow so that the metabolically more active skeletal muscles receive the greatest proportion of the cardiac output (33, 88,89,90). The redistribution of blood flow during exercise result from vasoconstriction of the larger arterioles supplying the metabolically more active skeletal muscles (104).

The vasodilation of arterioles and metarterioles and increase in blood flow (exercise hyperemia) that occur in active skeletal muscle is due, in part, to the following 1) a local effect caused by an increase in temperature, CO₂, potassium ions, hydrogen ions, and adenosine and lactic acid levels and a decrease in O₂ (48). 2) the release of vasodilatory substance called endothelial-derived relaxing factors (the most studied of which is nitric oxide, NO) from the innermost layer of smooth muscle cells of an arterial blood vessel, the intima (9,17,30,80,48,65,67). 3) an initial sympathetic cholinergic reflex response in the arterioles of active muscles (83).

Several studies involving effect of different exercise in vasodilation, Tschakovsky and co-worker (1996) reported that a functional muscle pump does exist in the human forearm in vivo, but that a rapid vasodilation detectable within 2 s also contributes to the early exercise hyperemia (100). Chauyng and co-worker (2000) have reported that exercise training increase agonist-stimulated nitric oxide, NO release and enhances endothelium-dependent vasodilation in vessels obtained from normal or hypertensive animals. Chauyng and co-worker (2002) found that chronic exercise partially reduces vascular structural changes, impairs EC [Ca²⁺]_i signaling and vasodilation in hypercholesterolemic rabbit femoral artery (10). Timothy Musch and co-worker (2003) found similar increases in total hindlimb blood flow in young and old rats during submaximal exercise (99). Cheriff (2003) found that hindlimb blood flow changes directly with speed (when vasodilation caused by changes

in speed and grade oscillations out of phase (slow uphill, fast downhill)) indicates that there is a direct coupling of stride frequency and hindlimb blood flow (i.e, muscle pumping)(18). Michael and co-worker (2003) found that increasing muscle contraction frequency, which alters the duty cycle and metabolic rate, would increase the contribution of the contractile phase to mean venous blood flow in isolated skeletal muscle during rhythmic contractions(77). Calbet and co-worker (2003) found that during the Wingate test in normoxia, sprint cyclists relied more on anaerobic energy sources than endurance cyclist. Sprint cyclist achieved higher peak and mean power output, and 33% larger oxygen deficit than endurance cyclist (7).

Short running is the sports that muscle strength plays an important role. The training for short runners is extremely specialized and specific to the movement involved and obviously concentrates mainly on developing maximum strength (Elliott, 1989). Energy supply for short runners was mainly from anaerobic system from glycogen in muscles. Anaerobic sources supply most of the energy for rapid movements, or during increased resistance to movement at a given speed. When movement begins at either fast or slow speed, the high energy phosphates provide immediate anaerobic energy for muscle actions. After a few seconds, the glycolytic pathway generates an increasingly greater proportion of energy for ATP resynthesis. When intense exercise continues beyond 30 seconds, a progressively greater demand is placed on the relatively slower aerobic energy metabolism of the stored macronutrients (22).

Long running is the sports that endurance of body systems plays an important role. The training for long runners is extremely specialized and specific to the tolerance of musculoskeletal and cardiopulmonary system. Energy supply for long runners was applied from aerobic system that need oxygen support to the biochemical reactions. Aerobic sources supply most of the energy for long time movements. Energy was produced from chemical reaction with oxygen system. The oxygen system is used during low intensity, long duration exercise (22).

Therefore, it could be hypothesized that there should be differences in vasodilational response in athlete trained by different metabolic energy systems. Since there are differences in detailed motor unit activation during their exercise training and

there should be differences in patterns of autonomic nervous system activations. In addition, the kinetics of smooth muscle responses in the muscles to exercise should be different.

Objectives:

1. To determine alterations of vasomotor responses to exercise stimulation of arms and legs of trained aerobic and anaerobic subjects of vasomotor response mechanism to prolonged exercise training.
2. To determine extremity's volume changes resulted by exercise stimulation.
3. To correlate the heart rate alterations monitored simultaneously during above treatments with alterations of the vasomotor parameters.
4. To compare differences in response of upper and lower extremities to the same stimulus used mentioned above.

CHAPTER 2

LITERATURE REVIEW

Exercise

Exercise was defined as structured physical activity which focuses on the intent to improve one or a combination of the basic element of fitness: cardiovascular endurance, muscular endurance, muscular strength and muscular and joint flexibility (47). Lennart Jungrsten and co-worker (1997) showed that both physical fitness and acute exercise can regulate nitric oxide formation on endothelium of vessels in healthy humans. They concluded that physical fitness and formation of nitric oxide on endothelium of vessels at rest are positively linked to each other, a single session of exercise elicits an acute elevation of nitric oxide formation. The observed positive relation between physical exercise and nitric oxide formation may help to explain the beneficial effects of physical exercise on cardiovascular health (63). Some physical activities rely predominantly on a single system of energy transfer, whereas more than one energy system energizes most physical activities, depending on their intensity, duration, frequency, and nutritional status. In 2002, Robert Carter III and co-worker presented effects of mode of exercise recovery on thermoregulatory and cardiovascular response in eight healthy men, these data suggest that skin blood flow and sweat rate during recovery from exercise may be modulated by nonthermoregulatory mechanisms and that sustained elevations in skin blood flow and sweat rate during mild active recovery may be important for postexertional heat dissipation (86). Therefore aerobic and anaerobic exercise provide a generalized overview of the relative contribution to energy metabolism of nutrition for adequate nourished individuals during rest and various exercise intensities (70).

Energy supply processes for muscular work needs are met by the transformation of potential energy in chemical bonds to mechanical energy for work. Muscular contraction can only proceed via the breakdown of adenosine triphosphate (ATP),

which is an energy rich molecule in short supply in the human body. ATP is the body's basic energy currency and thus, must be replenished for muscular contraction to continue. Fortunately, this can occur via anaerobic metabolism (without the presence of oxygen) as well as through aerobic metabolism (in the presence of oxygen) (102). There are three common energy processes for the production of ATP: 1) ATP-PC (Phosphagen system) 2) Anaerobic glycolysis (lactic acid system) 3) Aerobic system (oxygen system)

Table 1 General Characteristics of the three systems by which ATP is formed

System	Fuel	O ₂ required	Speed	Relative ATP production
Anaerobic				
ATP-CP system	Phosphocreatine	No	Fastest	Few;limited
Lactic acid system	Glycogen (glucose)	No	Fast	Few;limited
Aerobic				
Oxygen system	Glycogen, fats, proteins	Yes	Slow	Many;unlimited

(Edward Fox, Richard Bowers, Merle Foss; The Physiological Basic for Exercise and Sport; 5th edition; 31, 1993)

Two of three metabolic systems involved in ATP resynthesis mentioned previously, the ATP-PC (phosphagen system) and anaerobic glycolysis (lactic acid system) are anaerobic. Anaerobic means without oxygen and metabolism refers to the various series of chemical reactions that take place within the body. The ATP-PC (phosphagen system) included adenosine triphosphate (ATP) and phosphocreatine (PC) that both of it contain phosphate groups. The end products of this breakdown are creatine (C) and inorganic phosphate (Pi). The energy is immediately available and is biochemically coupled to the synthesis of ATP. As rapid as ATP is broken down during muscular contraction, it is continuously re-form from ADP and Pi by the energy liberated during breakdown of the stored PC. The important of the phosphagen system to athletics found in the powerful, quick start of sprinters, high jumper and by similar activities that required only a few seconds to complete. The phosphagen system represents the most rapidly available source of ATP for use by the muscle.

Some of the reason for this is 1) it does not depend on a long series of chemical reactions. 2) It does not depend on transporting the oxygen we breathe to the working muscle. 3) Both ATP and PC are stored directly within the contractile mechanism of the muscle. The other anaerobic system in which ATP is resynthesized within the muscle, anaerobic glycolysis; involves an incomplete breakdown of carbohydrate to lactic acid. In the body, all carbohydrates are converted to the simple sugar glucose, which can either be immediately used in that form or stored in the liver and muscle as glycogen for later use. Lactic acid is a product of anaerobic glycolysis. Glycogen is chemically broken down into lactic acid by a series of reaction. During this breakdown, energy is released and, though coupled reaction, it is used to resynthesized ATP. Anaerobic glycolysis, like the phosphagen system, is extremely important to us during exercise primarily because it also provides a relatively rapid supply of ATP. Lactic acid is produced and tolerated so that a precious few additional ATPs can be generated. Albeit, not many, but a few more until the cells become so acidic that they cannot effectively function. This ability to continue to generate some ATP and tolerate the buildup of lactic acid and compromised muscle function may have important implications for survival in life threatening situations. The most rapidly accumulated and highest lactic acid levels are reached during exercise that can be sustained for 60-80 seconds. (21)

The another one common energy processes is aerobic system (oxygen system). In the presence of oxygen, When 1 mole of glucose from glycogen is completely broken down to carbon dioxide (CO_2) and water, releasing sufficient energy to resynthesize 39 moles of ATP. There are many steps of reactions of the aerobic system which can be divided into three main series: first, aerobic glycolysis; the first series of reaction involved in the aerobic break down of glycogen to CO_2 and H_2O is glycolysis. Oxygen does this by diverting the majority of the lactic acid precursor (pyruvic acid), into the aerobic system. Second, the Krebs cycle; the pyruvic acid formed during aerobic glycolysis passes into the mitochondria and continues to be broken down in a series of reactions. A number of significant events occur during the cycle, carbon dioxide and ATP is produced, oxidation occur. Last; continuing in the breakdown of glycogen, the end product, H_2O , is formed from the hydrogen ions and electron that are removed in

the Krebs cycle. In this reaction 39 moles of ATP are generated per 1 mole of glucose (21).

Aerobic Training

There are two important factors in formulating an aerobic training program. For one thing, the training must be geared to provide a sufficient cardiovascular overload to stimulate increase in stroke volume and cardiac output. This central overload should be accomplished with the appropriate muscle groups to concurrently enhance the local circulation and metabolic machinery within the specific muscle. This essentially embodies the specific principle as applied to aerobic training. Simply stated, runners should run, cyclists should bicycle, and swimmers should swim. Brief bouts of repeated exercise (interval training) as well as continuous, long-duration work (continuous training) enhance aerobic capacity, if the exercise is sufficiently intense to overload aerobic system. Interval training, continuous training, and Fartlek training are three common methods to improve aerobic fitness (71).

Interval training: Many elite athletes attribute their success to interval training (29). With the correct spacing of exercise and rest periods, a tremendous amount of work can be accomplished that would not normally be completed in a workout in which the exercise was performed continuously. Repeated exercise bouts (with rest periods or relief intervals) can vary from a few seconds to several minutes or more depending on the desired outcome (14). The interval training prescription can be modified in terms of intensity and duration of the exercise interval, the length and type of relief interval, the number of work intervals (repetition), and the number of repetition blocks (sets) per workout. Adjustment of any or all of these can easily be made to meet the specific requirements for different performances. This offers flexible options for developing the anaerobic and aerobic energy transfer systems. A longer work interval engages the aerobic system, whereas shorter exercise intervals place greater overload on the anaerobic energy system. One value of interval training is that it permits high intensity, intermittent exercise for a relatively long period. In essence, a person can reach max VO_2 repeatedly in a training session. For example, few people can maintain a 4 minute mile pace for longer than a minute, let alone complete a mile within 4 minutes. If running interval, however, were limited to only 15 seconds

followed by 30 seconds of recovery, it would not be exceedingly difficult to maintain these exercise-rest intervals and complete the mile in 4 minutes of actual running. Although this dose not suggest a world class performance, the point is that a significant quantity of normally exhausting work at high levels of both aerobic and anaerobic metabolism can be achieved with the proper spacing of rest and work intervals (71).

In the example of a continuous run at a 4 mile pace, a large portion of energy would be supplied through anaerobic glycolysis. Within a minute or two, lactic acid levels would rise precipitously and the runner would become exhausted. With interval training, repeated work bouts of about 15 seconds would permit a severe load to be imposed on the aerobic energy system of specific muscles without an appreciable buildup of lactic acid. Fatigue incurred during the work interval would be minor and recovery could take place quickly. The work interval could then begin after only brief rest period, and a high level of aerobic metabolism would be sustained. For training the long term aerobic energy system, the work-recovery interval ratio is usually 1 to 1 or 1 to 1.5. During a 60 to 90 second exercise interval, for example, oxygen consumption is insufficient to meet the energy requirements of the exercise. The recommended recovery interval enables the succeeding exercise interval to begin before recovery is complete. This ensures that the circulatory an aerobic metabolic stress reach near peak levels even though the exercise are interval relatively short. With longer periods of intermittent exercise there is sufficient time for metabolic and circulatory adjustments, thus, the duration of the rest interval is not as crucial (71).

Continuous Training: continuous or long slow distance training involves steady-paced exercise performed at either moderate or high aerobic intensity (60 to 80 % max VO_2) for sustain duration. The exact pace can vary, but it must be sufficient threshold intensity to ensure physiologic adaptation. The method to establish this threshold so that the person might exercise in the “training-sensitive zone” was outlined previously. Continuous training for an hour or longer is popular among joggers and other fitness enthusiasts as well as competitive endurance athletes. It is not common for distance runners to train twice a day on a yearly basic and run between 100 to 150 miles each week. By its nature, continuous exercise training is submaximum and, therefore, can be engaged in for considerable time to relative comfort. Because of the potential

hazards of high intensity interval training for coronary-prone individuals, continuous training is particularly suitable for those just beginning an exercise program. When applied in athletic training, continuous training is really over-distance training, with most athletes covering between two to five times the actual distances of their racing event. It is believed that over-distance training produces the largest aerobic adaptations in both the central circulation and peripheral tissues. Overload is generally accomplished by increase exercise duration, although the work rate increase progressively as training improvements are achieved. One of the advantages of continuous training is that it permits training at nearly the same intensity as actual competition. Because the recruitment of appropriate motor units depends on work rate, continuous training may be best suited for the endurance athlete in term of adaptations at the cellular level (28).

Fartlek Training: fartlek or speed play training is a relatively unscientific adaptation of interval and continuous training that is well suited for exercising to of doors over natural terrain. With this system, alternate running is done at both fast and slow speeds on both a level and hilly course. In contrast to the precise exercise prescription in interval training, fartlek training dose not require systematic manipulation of the work and relief intervals. Instead, the performer determines the training scheme based on “how it feels” at the time. If done properly, this system develops one or all of the energy system. An added advantage is the flexibility it affords in determining the extent of training. Although lacking the systematic and quantified base of interval and continuous training, fartlek training is ideally suited for general conditioning or off-season training and for maintaining a certain freedom and variety in workouts (71).

Aerobic overload training significantly improves a variety of functional capacities related to oxygen transport and use (40). The most notable adaptations accompanying aerobic training include the following: (72)

1. Mitochondria from trained skeletal muscle have a greatly increased capacity to generate ATP aerobically by oxidative phosphorylation.
2. Associated with the increased capacity for mitochondria oxygen uptake is an increase in both the size and number of mitochondria and a potential twofolds increase in the level of aerobic system enzymes.

3. Skeletal muscle myoglobin content of animals increase by as much as 80%.

4. There is an increase in the trained muscle's capacity to mobilize and oxidize fat. This occurs by an increase in blood flow within muscle and in the activity of fat mobilizing and fat metabolizing enzymes. At any submaximum work rate, a trained person uses more free fatty acids for energy than an untrained counterpart. This is beneficial to endurance athletes because it conserves the carbohydrate stores so important in prolonged exercise.

5. Trained muscle exhibits a greater capability to oxidize carbohydrate. Consequently, large quantities of pyruvic acid move through the aerobic energy pathways. This is consistent with the increase in oxidative capacity of mitochondria and increase glycogen storage within the trained muscle. In 1996, M.A. Febbraio and co-worker study examined the effects of elevated muscle temperature on muscle metabolism during exercise in seven active men. It is concluded that an elevated muscle temperature per se increase muscle glycogenolysis, glycolysis, and high energy phosphate degradation during exercise. These alterations may be the result of an increased rate of ATP turnover associated with the exercise and/or changes in the anaerobic/aerobic contribution to ATP resynthesis (26).

6. Aerobic training produces metabolic adaptations in the different types of muscle fibers.

7. There may also be selective hypertrophy of different muscle fibers to specific overload training. Highly trained endurance athletes show larger slow-twitch fibers than fast twitch fibers in the same muscle.

8. Body heat transfer: well-hydrated, trained individuals exercise more comfortably in hot environments because of a larger blood volume and a more responsive heat regulatory mechanism. Trained individuals dissipate heat faster and more economically and thereby cool the body more effectively. This means that the metabolic heat generated by exercise causes less heat strain and thus prolongs exercise tolerance. In 1976, Erika Baum and co-worker study in seven long distance runners the thermoregulatory response to acute external cooling and heating under resting conditions. They found the runners thus behaved as if the set point of their thermoregulatory system had been reset to a lower level, the shift is quantitatively comparable to that found in heat adaptation as for the sweating threshold. The

described modifications in long distance runners would prolong the time period until a dangerous body temperature (23). In 1991, Dean L. Kellogg, Jr. and co-worker studied control of internal temperature threshold for active cutaneous vasodilation by dynamic exercise, it is concluded that reflexes associated with exercise cause elevation vasodilator threshold by delaying activation of the active vasodilator system during exercise, rather than through the adrenergic vasoconstrictor system (15).

9. Related cardiovascular and respiratory change: the cardiovascular and respiratory system are intimately linked with aerobic processes, related changes occur that are both functional and dimensional:

a. Heart size: the weight and volume of the heart generally increase with long term aerobic training (81). A mild cardiac hypertrophy is a normal training adaptation characterized by an increase in the size of the left ventricular cavity as well as by a thickening of its walls. This cardiac enlargement return to control level with reduced training intensity.

b. Blood volume: plasma volume and total hemoglobin tend to increase with endurance training. This adaptation may enhance circulatory and thermoregulatory dynamics to facilitate oxygen delivery capacity during exercise. In 1983, S.M. Fortney and co-worker presented effect of blood volume on forearm venous and cardiac stroke volume during exercise in five healthy men exercised at 65-70% of VO_2 max in 30 minutes. The patterns of stroke volume over the course of exercise indicates that pooling of blood in veins may be quantitatively more important than plasma water loss in reducing cardiac filling pressure in the heat (27). In 1984, H.J. Green and co-worker investigate the role of high intensity intermittent exercise on adaptations in blood volume and selected hematological measurement, the findings of this study suggest that exercise intensity is a major factor in promoting exercise induced hypervolemia and that rapid elevations in plasma volume can be induced early in training (32). In 1990, B. Nielsen and co-worker study the effect of heat stress on blood flow and metabolism in an exercising leg in seven subjects walking uphill for 90 minutes. They concluded that a flow limitation to the exercising muscle, and subsequent altered metabolism, is not what makes it impossible to continue the exercise in the heat in the present circumstances, it may be that the high core

temperature has an effect on the central nervous system in reducing mental drive for motor performance (82).

c. Heart rate: resting and submaximal exercise heart rate decrease during aerobic training, especially for previously sedentary individuals. Consequently, heart rate changes provide a convenient index to measure training improvement (71).

d. Stroke volume: the heart's stroke volume increase significantly at rest and during exercise. Large stroke volumes are evident among endurance athletes and generally result from a large ventricular volume accompanied by enhanced myocardial contractility (71).

e. Cardiac output: the most significant change in cardiovascular function with aerobic training is the increase in maximum cardiac output. Because the maximal heart rate may even decrease slightly. The heart's increased outflow capacity results directly from improved stroke volume. A large cardiac output is a major factor that distinguishes champion endurance athletes from well-trained and untrained individuals (71).

f. Oxygen extraction: training produces significant increases in the amount the oxygen extracted from the circulating blood. And increase in the arteriovenous oxygen difference results from a more effective distribution of the cardiac output to working muscles, as well as of enhanced capacity of the trained muscle cells to extract and utilize oxygen. In 1994, B. Falk and co-worker determine whether age related differences in the response to cold exposure are due to aging per se or are caused by a reduced maximal oxygen uptake. They concluded that older age per se, are not the cause that reduced VO_2 max, is responsible for the age related difference in responses to rest and exercise in the cold (25).

g. Blood flow and distribution: there is some indication that trained individuals perform submaximal exercise with a relatively lower cardiac output than untrained counterparts. Aerobic training causes large increase in total muscle blood flow during maximal exercise due to: improvements in maximal cardiac output, and redistribution of blood from nonworking areas that temporarily compromise their blood flow in response to all-out effort. In 1975, John M. Johnson and Loring B. Rowell determine the cutaneous and resting skeletal muscle vascular responses to prolonged leg exercise in man, the results suggest that the progressive decrements in

central venous pressure, stroke volume, and arterial pressure previously seen during prolonged exercise are due in part to progressive increments in cutaneous blood flow and volume (43). In 1991, C.G. Tankersley and co-worker study sweating and skin blood flow during exercise: effects of age and maximal oxygen uptake, these findings suggest that during a short exercise bout there is no primary effect of aging on heat loss responses but, rather, changes are associated with the age-related decrease in VO_2 max or the decline in heat loss responses due to aging may be masked by repeated exercise training (96). In 1991, Takashi Nishiyasu and co-worker determine the influence of hypovolemia on the control of forearm vascular resistance during dynamic exercise in five active men. They concluded that reduced blood flow to the periphery during exercise in the hypovolemic condition was caused entirely by an increase in vascular resistance, thereby preserving arterial blood pressure and adequate perfusion to the organs requiring increased flow (94).

h. Blood pressure: regular aerobic training tends to reduce both systolic and diastolic blood pressure during rest and submaximal exercise. The largest decrease occurs in systolic blood pressure and are most apparent in hypertensive subjects (71).

i. Respiratory function: increased breathing volumes accompany improvements in max VO_2 . Higher maximum ventilation is due to increases in both tidal volumes and breathing frequency. This adaptation should be helpful in prolonged exercise because increased ventilatory economy means more oxygen availability to the working muscles (71).

Anaerobic Training

The capacity to perform and maintain in all out exercise for brief periods of time up to 60 seconds is largely dependent on ATP generated by the immediate and short term anaerobic energy system. Methods of anaerobic training had common objective to develop phosphagen used to generate energy in athletes.

The phosphate pool: sports such as weightlifting and various other brief sprint activities rely almost exclusively on energy derived from the muscle's phosphate pool. The phosphate pool can be overloaded by engaging specific muscles in repeated maximum bursts of effort for 5 to 10 seconds. Because the high energy phosphate supply energy for intense, intermittent exercise, only small amounts of lactic acid are

produced and recovery is rapid. Thus, a subsequent exercise bout can begin after a 30 to 60 second rest period. This use of brief all out work periods interspersed with recovery represents a specific application of interval training, a technique useful for anaerobic conditioning. In training to enhance the ATP-CP energy capacity of specific muscles, the activities selected must engage the muscles at the appropriate speed of movement for which the athlete desires improved anaerobic power. Not only does this enhance the anaerobic metabolic capacity of the specifically trained muscle fibers, but it also facilitates the recruitment of the appropriate motor units used in the actual movement.

Lactic acid: as the duration of all out effort extends beyond 10 seconds, dependence on anaerobic energy from the phosphates decreases while the quantity of anaerobic energy generated in glycolysis increases. To improve capability for anaerobic energy release via the short term lactic acid energy system, the physiologic conditioning program must overload this aspect of energy metabolism. Heavy anaerobic training is psychologically taxing and requires considerable motivation. Repeat bouts of up to 1 minute of maximum running, swimming, or cycling stopped about 30 seconds before subjective feeling of exhaustion, cause lactic acid to increase to near maximum levels. Each exercise bout should be repeated after 3 to 5 minutes of recovery. Several repeats cause a lactate stacking that result in higher levels of lactic acid than just one bout of all out effort to the point of voluntary exhaustion. Of course, it is critical to use the specific muscle groups the require this enhance anaerobic capacity. The time necessary for recovery can be considerable when exercise involves a significant anaerobic component. Anaerobic power training should occur at the end of conditioning session. Otherwise, fatigue would carry over and perhaps hinder the efficiency of subsequent aerobic training (71).

In keeping with the concept of specificity of training, activities that demand a high level of anaerobic metabolism bring about specific changes in the immediate and short term energy system, without a concomitant increase in aerobic functions. Specifically, the metabolic changes that occur with sprint and power type training include:

1. Increases in resting levels of anaerobic substrates: as determined from muscle biopsies taken before and after resistance training 28% improvement in strength was

accompanied by significant increases in the muscle's resting levels of ATP, CP, free creatine, and glycogen (41, 74).

2. Increases in the quantity and activity of key enzymes that control the anaerobic phase of glucose breakdown: these changes are not of the magnitude observed for oxidative enzymes with aerobic training. The most dramatic alteration in anaerobic enzyme function and increase in fiber size occur in the fast twitch muscle fibers.

Increases in capacity for levels of blood lactate during all out exercise that follow anaerobic training: this is probably due to enhanced levels of glycogen and glycolytic enzyme, as well as to improved motivation and pain tolerance to fatiguing exercise. Increased anaerobic exercise capacity is also observed concurrent with metabolic adaptation (73). In 1979, McMurray, R.G. and co-worker presents thermoregulation in six trained swimmers and five runners to cold and heat were evaluated during 30 minutes of exercise. They found runners were able to attain higher sweat rates than swimmers in 35°C water. Swimmers had significantly greater tissue conductance values in the 35°C exposure. Swimmers thermoregulated were better in 20°C water than runners. Physical training in water does not improve heat acclimatization to the extent of training in air, but does improve cold tolerance (75).

Vasomotor

The main function of the vasculature is to deliver metabolic requirements to the tissue of the body. Some tissues have a greater need than others depending on their functions at a given time (e.g. muscles in exercise). Some tissues can survive without these substrates longer than others e.g. muscle cells can survive hypoxia for hours, whereas the brain will die within minutes in similar hypoxia (87).

Control of blood vessels

Local control mechanism: this is a main control mechanism in skin. High temperature causes vasodilation in skin arterioles and veins. At temperatures of 12-15°C, vasoconstriction of skin vessels occurs. This appears to be caused by noradrenergic stimulation of α_2 -adrenoceptors. Below 12°C, paradoxical cold vasodilation occurs caused by neurotransmitter release impairment and the vasodilator substances e.g. prostaglandins are released. In most other tissues, vasodilation

occurs in response to cold. This is probably related to the predominance of α_1 -receptors in other tissues compared with α_2 -receptors in the skin. In 1976, John M. Johnson and co-worker presented interactions between local and reflex influences on human forearm skin blood flow. They concluded that local and reflex influences to skin interact so as to modify the degree but not the pattern of skin vasomotor response (45). Cleroux and co-worker presents baroreflex regulation of forearm vascular resistance after exercise in hypertensive and normotensive humans in 1992. They suggested that the after effects of exercise could not be attributed to changes in cutaneous blood flow (42). Transmural pressure: This is the pressure across the wall of the vessel and can be affected by external and internal pressures: External pressure, blood flow is impaired by a high external pressure outside the vessel e.g. when muscle is contracting or when sitting or kneeling. Internal pressure, initially, raised blood pressure causes the vessel to distend briefly. This causes the smooth muscle to be stretch, producing flow within the vessel. This is termed the myogenic response and is a mechanism of autoregulation. In 1992, Carten Stick and co-worker study investigates whether walking or running prevents the formation of edema in the lower leg. The experimental results prove that walking prevents dependent edema formation, however, cannot be fully explained by the lowered venous pressures (8). Local metabolites: many metabolites cause vasodilatation and increase perfusion of the tissue. These include: hypoxia (decrease pO_2), acidosis (causes by CO_2 and lactate), adenosine triphosphate (ATP) breakdown products, K^+ from contracting muscle and brain neurons, increase in osmolarity. Different tissues are influenced to varying degrees by these factors; for example, coronary vessels react mainly to hypoxia and adenosine whereas cerebral vessels are influenced by K^+ and H^+ (87).

Cytokines are chemical substances that can produced and secreted locally and act locally as local hormones, producing local responses e.g. inflammation. They include (87):

1. Histamine: This is an inflammatory mediator that causes arteriolar vasodilatation (H_1 -receptor mediated). In veins, it causes vasoconstriction and increases permeability (H_2 -receptor mediated) (87).

2. Bradykinin: This inflammatory mediator causes vasodilatation nitric oxide (NO) mediated and increase vascular permeability (mediator by Ca^{2+}) (87).

3. 5-Hydroxytryptamine (5-HT, serotonin): This is found in platelets, the intestinal wall, and the central nervous system. It causes vasoconstriction (87).

4. Prostaglandins (PGs): These are inflammatory mediators synthesized from arachidonic acid by cyclooxygenase. They are produced by macrophages, leucocytes, fibroblasts, and endothelium. Their production is inhibited by nonsteroidal anti-inflammatory drugs (NSAIDs) and steroids. PGF causes vasoconstriction, PGE causes vasodilatation, and PGI₂ (prostacyclin) causes vasodilatation (87).

5. Thromboxane: This is a platelet activator that causes vasoconstriction; it is involved in haemostasis (87).

6. Leukotrienes: These are inflammatory mediators synthesized from arachidonic acid by lipoxygenase. They are produced by leucocytes, and cause vasoconstriction and increased vascular pressure (87).

7. Platelet activating factor (PAF): This is an inflammatory mediator that causes vasodilatation, increased vascular permeability, and vasospasm in hypoxic coronary vessels (87).

Endothelium dependent relaxation and contraction: when stimulated, the endothelium of arteries and veins produce endothelium derived relaxing factor (EDRF). EDRF was discovered to be nitric oxide (NO) and it is produced in endothelial cells by cleavage from L-arginine by NO synthetics. In 1999, G. Radegran and B. Saltin study the role of nitric oxide as a regulator of vasomotor tone has been investigated in resting and exercising human skeletal muscle. These findings indicate that nitric oxide is not essential for the initiation or maintenance of active hyperemia in human skeletal muscle but support a role for nitric oxide during rest, including recovery from exercise. Moreover, changes in blood flow during rest and recovery caused by nitric oxide synthase inhibition are accompanied by reciprocal changes in oxygen extraction, and thus VO₂ is maintained (85). Stimuli include thrombin, bradykinin, substance-P, adenosine diphosphate (ADP), acetylcholine, and histamine. NO diffuses into smooth muscle cells and activates on intracellular cyclic guanosine monophosphate (cGMP) messenger system and causes vasodilatation. Blood flowing through an artery causes shear stress on the endothelial cell. When arterioles dilate to increase tissue perfusion, flow increases in feeder arteries by a process called flow induced vasodilatation. This process is caused by increase shear stress, increasing NO

production. Vasoconstriction substances are also produced by the endothelium prostanoid is produced in large arteries to cause constriction in response to hypoxia; endothelin is a powerful vasoconstrictive peptide (87).

Autoregulation is the process whereby tissue perfusion remains relatively constant even though blood pressure changes. It also keeps capillary filtration pressure at a stable value. Flow is proportional to pressure/resistance. Therefore, to keep flow constant, any pressure change must be opposed by a resistance change. An increase in pressure causes arteriolar vasoconstriction, thereby increasing resistance. A decrease in pressure causes arteriolar vasodilatation and decreases resistance. It takes 30-60 s for the effect to take place so, for example, there is an initial increase in flow with a pressure increase before a steady state is reached. Autoregulation only occurs over a limited pressure range. It is an intrinsic feature of the vessels and is independent of nervous control. However, it does not mean that tissue perfusion is constant all the time *in vivo*. In 1982, John M. Johnson and Myung K. Park presented effect of heat stress on cutaneous vascular responses to the initiation of exercise. These finding a cutaneous participation in the vasoconstrictor responses to exercise but also indicate that sufficient hyperthermia can attenuate or even abolish this response (44). In 1994, Michael B. Ducharme and Peter Tikuisis investigate the relative contribution of the convective heat transfer in the forearm and hand to the total heat loss during partial immersion in cold water and the heat gained during partial immersion in warm water. These results suggest that during local cold stress the convective heat transfer by the blood has a greater role than that suggested by previous studies for the forearm but a lesser role for the hand (78). Autoregulation can be reset to work at a new level by an increases sympathetic drive for instance. The mechanisms for autoregulation are: Myogenic response: Increased pressure produces constriction of the vessel, opposing the rise in pressure and stabilizing blood flow. Vasodilator washout: This is the effect that blood flow has on the concentration of the local vasodilator metabolites. If blood flow increases, these metabolites are washed away faster, causing the vessel to constrict, thereby increasing resistance and slowing flow. In the heart, any increases in coronary arterial pressure causes a rise in tissue pO₂, leading to vasoconstriction; this autoregulates heart blood flow (87).

Metabolic (or functional/active) hyperaemia is the increase in blood flow that occurs in exercising muscle and secreting exocrine glands when their metabolic rate increases. The production of local vasodilator metabolites leads to vasodilatation and causes vascular resistance to fall. Flow induced vasodilatation cause the main artery to dilate. Ascending dilatation from the arterioles to the feeder arteries leads to dilatation of the whole arterial tree supplying the tissue. Blood flow in contracting muscle is increased in the resting phase. In the heart, the increase in metabolic rate causes a drop in tissue pO_2 , leading to vasodilatation (87).

Reactive (or postischaemic) hyperaemia is the increase in blood flow that occurs after supply to a tissue has been temporarily interrupted. Reactive hyperaemia enables resupply to ischemic tissue as quickly as possible. The myogenic response is the predominant mechanism for brief occlusions. In more prolonged occlusions, vasodilator metabolites accumulate and play a significant role. Prostaglandins also aid this process. Reactive hyperaemia is temporary and decays exponentially. A plateau of hyperaemia may precede decay in prolonged occlusions. In some tissues e.g. the heart, there is oversupply of blood and oxygen compared with the deficit during the temporary interruption to flow (87).

Ischemic reperfusion injury: when blood flow to a tissue is interrupted for a prolonged period reactive hyperaemia is impaired. Reperfusion of ischemic tissue results in superoxide and hydroxide radical formation. These can damage the tissue and vessel wall, causing further occlusion. Damage is exacerbated by an increase in K^+ and tissue acidosis. Reperfused cells have an impaired plasmalemmal barrier to Ca^{2+} ions, which flow into the cell in an unrestricted way, causing calcium overload damage. It is thought that reperfusion injury exacerbates damage to the myocardium, intestine, and brain following ischemia (87).

Nervous control

Sympathetic vasoconstrictor nerves: sympathetic vasoconstrictor nerves innervate the vascular smooth muscle of the resistance and capacitance vessels. A basal level of activity of these nerves is responsible for vessel tone at rest. The neurotransmitter involved is noradrenalin which acts on α_1 -receptors on vascular smooth muscle causing contraction. When there is an increase in sympathetic drive: vasoconstriction decreases

local blood flow, vasoconstriction decrease local blood volume, arteriolar constriction decrease capillary pressure, leading to greater absorption of fluid from the interstitium. If there is an increase in sympathetic activity throughout the body, total peripheral resistance and cardiac output increase. This constitutes the basic of the sympathetic response to haemorrhage. A decrease in sympathetic activity causes vasodilatation and vasodilatation (87).

Sympathetic vasodilator nerve: some tissues (skeletal muscle and sweat glands) are also innervated by sympathetic vasodilator nerves. In skeletal muscle, vascular bed stimulation by these nerves (which use acetylcholine as the neurotransmitter and act on muscarinic receptors) causes vasodilatation. Stimulation only occurs as part of an alerting response and is initiated in the forebrain without any brainstem influence. The vasodilator effect is only temporary and plays no role in blood pressure regulation. Stimulation of these nerves in sweat glands probably involving vasoactive intestinal peptide (VIP) as neurotransmitter produces sweating and cutaneous vasodilatation(87).

Parasympathetic vasodilator nerves: parasympathetic vasodilator nerves innervate the blood vessels of: the head, salivary gland, pancreas, gastrointestinal mucosa, genitalia, and bladder. The effect of these nerves on the total peripheral resistance is small because of their limited innervation. Their postganglionic neurons release acetylcholine, which relaxes vascular smooth muscle. In some tissue e.g. pancreas, vasoactive intestinal peptide (VIP) may be the main neurotransmitter. Vasodilatation occurs in the arteries and arterioles of these vascular beds. In the erectile tissue of the penis, it is the parasympathetic vasodilatation that fills the corpus sinuses with blood, causing erection (87).

Hormonal control

Although the vasculature response is influenced by circulating hormones, short term control is mainly achieved by the nervous system.

Adrenaline: The catecholamines (adrenaline and noradrenaline) are secreted from the adrenal medulla. More than three times as much adrenaline is secreted as noradrenaline. Plasma levels at rest of adrenaline are 0.1-0.5 nmol/L, and noradrenaline 0.5-3.0 nmol/L. there is more noradrenaline in plasma because of spill over from sympathetic nerve terminals. Secretion is increased in exercise,

hypotension, hypoglycaemia, and fight or flight situations. Both hormones are β -adrenoceptor agonists, so they increase heart rate and contractility of the myocardium. Both hormones cause vasoconstriction in most tissues via α -receptors: adrenaline causes vasodilatation in skeletal muscle, myocardium, and liver. This is because there are more β -receptors in these tissues, and adrenaline has a higher affinity to these receptors. Noradrenaline usually causes vasoconstriction because it has a higher affinity to α -receptors. Adrenal gland stimulation results predominantly in adrenaline release, which causes vasodilatation in the large vascular beds of skeletal muscle and liver and increases stroke volume and heart rate. This leads to increased cardiac output, but with little change to blood pressure due to decreased total peripheral resistance. In 1985, John V. Chirstman and Carl V. Gisolfi study to anterior hypothalamic sensitivity to norepinephrine is altered by chronic exercise in the heat in male Sprague-Dawley rats. The data indicate that exercise in the heat increases norepinephrine induced peripheral heat dissipating capacity and increases catecholamine storage in the preoptic area (46). In 1990, Connelly, Terence P. and co-worker examine the influence of an increase in central blood volume with head-out water immersion on the sympathoadrenal response to graded dynamic exercise, nine healthy men underwent upright leg cycle exercise on land and water immersion. These results suggest that the central shift in blood volume with water immersion reduces the sympathoadrenal response to high intensity dynamic exercise (97).

Vasopressin (antidiuretic hormone, ADH): ADH is a peptide produced in the hypothalamus and released from the posterior pituitary into the bloodstream. A rise in plasma osmolarity is the main stimulus for secretion. A fall in blood pressure and volume are also stimuli, but to a lesser degree. ADH promotes water retention by the kidney. High levels of ADH cause vasoconstriction in most tissues. In the brain and heart, EDRF-mediated vasodilatation occurs. This ensures preferential supply to the brain and heart in hypovolaemia (87).

Renin-angiotensin aldosterone: Renin is an enzyme produced by the juxtaglomeruli cells of the kidney. Its production is increased by: a fall in afferent arterial pressure to the glomeruli, increase sympathetic activity, decrease Na^+ in the macula densa of the adjacent tubule. The formation of angiotensin II is action of this peptide are as follows. It stimulates aldosterone secretion from the adrenal cortex.

Causes vasoconstriction at high concentration by acting directly on vascular smooth muscle, initiating release of noradrenaline from sympathetic nerve terminals, and increasing central sympathetic drive in the brainstem, increases cardiac contractility. Aldosterone increases salt and water retention by renal tubules (87).

Atrial natriuretic peptide (ANP): In response to high cardiac filling pressure, specialized myocytes in the atria secrete ANP. ANP increases the excretion of salt and water by renal tubules. It also has a small vasodilating effect. Ventricles similarly secrete brain natriuretic peptide (BNP), which increases in heart failure. Levels of BNP may be used as a blood test for heart failure. In 1992, A Thermanias and co-worker study the influence of moderate cold exposure on the hormonal responses of atrial natriuretic factor, arginine vasopressin, catecholamine, and plasma rennin activity after exhaustive exercise. They found that the alterations in hormonal concentrations are likely to have been induced by changes in central blood volume and/or blood pressure, these hormonal responses may serve as a feedback mechanism modulating the blood pressure and volume responses to both exercise and cold exposure (98).

Regulation of circulation in individual tissues

Skeletal muscle: Oxygen and nutrient delivery to the muscle cells must increase with exercise. Removal of waste products and heat must also be increased during exercise. Physically active muscle consists of white fibres e.g. gastrocnemius. Postural muscles e.g. soleus are tonically active red fibres and have a greater capillary density. Sympathetic vasoconstrictor nerve reflexes controlled by baroreceptors play a major role in controlling flow. In hypovolaemia, for example, vasoconstriction can reduce flow in skeletal muscle to one-fifth of its resting value. During exercise, metabolic vasodilatation is the dominant mechanism for increasing flow. Adrenaline causes vasodilatation by acting on smooth muscle β_2 -receptors. At rest, only 25% of the oxygen in the blood is extracted. In severe exercise, this extraction can be increased considerably. Extraction is aided by the presence of myoglobin. The skeletal muscle pump aids venous return to the heart. This lowers venous pressure in the limbs. The pressure difference from the arterial to venous circulations increases. Thus, the perfusion pressure is increased, driving blood flow. Blood flow is impaired during contraction. If contraction is sustained then the fibres will become hypoxic. Lactate

will accumulate causing pain and strength will be rapidly lost. An increase in the capillary filtration rate can lead to a fall in plasma volume (87).

Cutaneous circulation: The skin has a low metabolic requirement and its vasculature is mainly involved in the regulation of the internal core body temperature. Specific areas of the skin have arteriovenous anastomoses. These exposed areas have a high surface area to volume ratio and include the fingers, toes, and palms, soles of the feet, lips, nose, and ears. These anastomoses are controlled by sympathetic vasoconstrictor nerves. In turn the sympathetic activity is controlled via the brainstem by the temperature regulating area in the hypothalamus. The nerves controlling sweating are also controlled in the same way when the core body temperature is too high, sympathetic drive is reduced and the arteriovenous anastomoses dilate. Skin temperature is very variable as it is influenced by ambient temperature. It has a direct effect on cutaneous vascular tone: local heating causes vasodilatation, local cooling causes vasoconstriction. Paradoxical cold vasodilatation occurs in acral areas (the extremities) on prolonged exposure to cold. After the initial vasoconstriction, vasodilatation occurs. This is thought to be because the cold impairs sympathetic vasoconstriction. This phenomenon prevents skin damage in such exposure. Skin temperature receptors can evoke a weak spinal reflex that changes sympathetic vasomotor activity. Hypotension causes a neural and hormonal (angiotensin, ADH, and adrenaline) vasoconstriction of skin vessels. This produces the cold skin seen in shock. Exercise causes vasoconstriction of the skin initially, but this can become a dilatation if the core temperature rises. Emotion can produce a hyperaemia response in the skin (blushing) and the gastric and colonic mucosa. Compression of the skin for long periods e.g. when sitting for a long time may impair blood flow. Reactive hyperaemia and the skin's high tolerance to hypoxia prevent ischemic damage. Restlessness (i.e. the desire to move position) also plays a major role, possibly stimulated by local metabolites and pain receptors. In certain patients. However, failure to move or be moved can lead to necrosis in compressed areas. In hot weather, cutaneous vasodilatation can lower central venous pressure. This can lead to fainting (87).

Cardiovascular response to training: this is most important in the long distance or endurance athletes. Training causes improvements in oxygen transport rate and

changes in cardiac structure and function. Causes of improved oxygen transport are: new capillaries formed in skeletal muscle, more muscle mitochondria closer to capillaries, increased muscle myoglobin concentration. Changes in cardiac structure and function are: thicker ventricular wall, increased myocardial vascularity, increased ventricular cavity size. Stroke volume is much higher because of the cardiac changes. Most athletes have a resting bradycardia, but because of the increased stroke volume the resting cardiac output is the same. In exercise, the athlete's maximum heart rate is the same as that for an untrained subject, but because the athlete starts at a lower value, a much greater change can be achieved. This coupled with the increased stroke volume means that the athlete can increase cardiac output up to as much as 35 L/min (87).

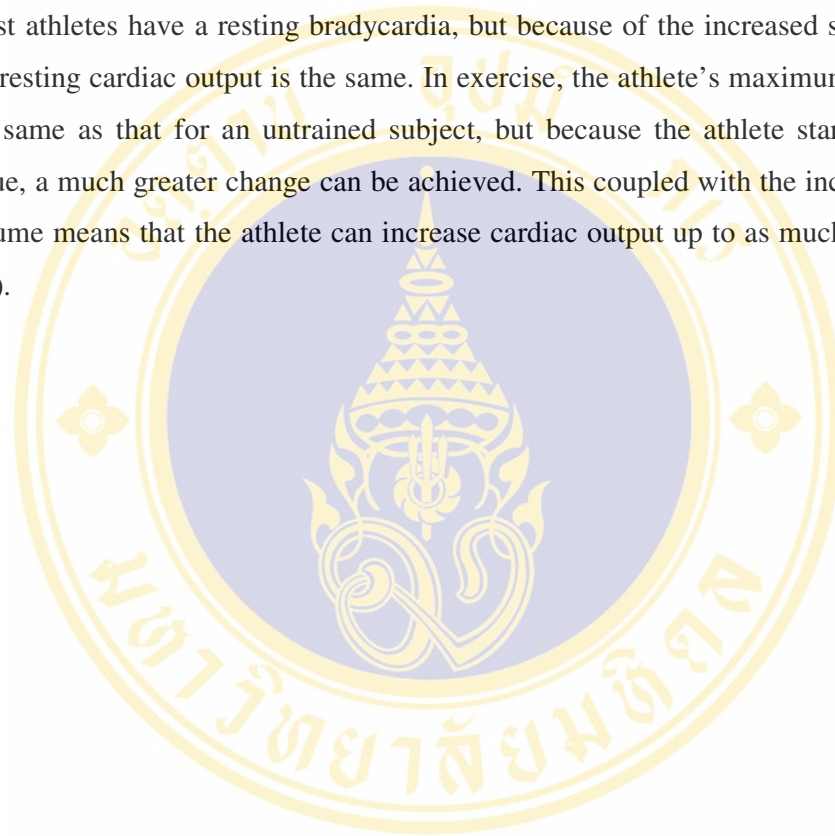

CHAPTER 3

MATERIALS AND METHODS

1. Subjects

Fourty healthy males (average age 20.5 yr; range 19-22 yr) volunteered to serve as subjects for this study. Fourteen subjects were short runners who had been trained under the same coached of the Sports Science Program, Rajabhat Loei University. The short runners had been trained for at least 8 week prior to this study. Throughout this training period, these subjects regularly running trained once a day, at least one hour per session, and 3 days a week. Fourteen subjects were long runner who had been trained under the same coaches of the Sports Science Program, Rajabhat Loei University. The short runners had been trained for at least 8 week prior to this study. Throughout this training period, these subjects regularly running trained once a day, at least one hour per session, and 3 days a week. Twelve subjects were sedentary who had been less physical activity and participated in sports activity of less than 1 hour during a week. Sedentary in control group were recruited from students of Education program, Rajabhat Loei University, Loei . The three subject groups were matched for their average age and Body Mass Index (BMI).

All subjects gave informed consent to the experimental protocol approved by the Human Right Committee of Mahidol University No.21/2004. No subject reported skin or cardiac disease or was known to be suffering from any chronic disease. None was on any regular medication.

2. Experimental protocols

On the first test day, each subject was familiarized once with each test. Data collection includes anthropometric measurement such as body weight, height, skinfold thickness, vital sign and physical fitness test. The tests were conducted at

Sports Science Laboratory, Sports Science Program, Rajabhat Loei University, Loei, Thailand

At least 1 day apart following the first test, all subject was measured upper and lower extremities volume by water displacement method in difference exercise stimulation. Subjects were tested for volume changing of extremities by three conditions stimulus that 1) Inflated blood pressure cuff by using pressure equal to systolic pressure plus 10 mmHg at the left upper arm for 4 minutes, the left forearm was immersed in volumeter (see Fig. 26, 27) for volume measurement 2) Inflated blood pressure cuff by use pressure equal to systolic pressure plus 10 mmHg at the right upper arm for 4 minutes, left forearm was immersed in volumeter for volume measurement 3) the Vo₂ max test (Astrand-Rhyming test), the subject was seated on the bicycle ergometer which the saddle height was adjusted appropriately, started pedaling the ergomrter at 0 Watt for 1 minute as a warm up period. Thereafter, the resistance was increase by 100-150 watts (600-900 kgm/min) until heart rate (HR) more than 120 beat/min. Start recording HR every minute until 6 minutes (24,39). Upper extremities and lower extremities were measured at volumeter for measurement volume (Fig. 26, 27). On the day three test, at least 1 day apart follow the second test day, all subject was measured upper and lower extremities volume by water displacement method in difference exercise stimulation. Subjects were tested for volume changing of extremities by three conditions stimulus that 1) Pulling pulley with the left hand with resistance 15% maximum voluntary contraction (MVC) continuously, hold 2 minutes, the left forearm was immersed in volumeter for measurement of volume 2) Pulling pulley with the right hand with resistance 15% maximum voluntary contraction (MVC) continuously, hold 2 minutes, the left forearm was immersed at volumeter for volume measurement 3) Wingate test, start pedaling the ergometer at freeload for 1 minute as a warm up period. The resistance was set to 75 g/kg for Monark ergometer (24, 55). Subject continue pedaling at highest speed for 30 seconds. Upper and lower extremities were immersed at volumeter for volumemeasurement. Volume changed of four extremities and heart rate were recorded in the plastic bag at six times before each test conditions (Pre), during test (Ts), at minute 1-2 (T₁), at minute 5-6 (T₂), at minute 9-10 (T₃), at minute 16-17 (T₄), except in Vo₂ max test and Wingate test conditions were recorded at five times

before each test conditions (Pre), during test (Ts), at minute 1-2 (T_1), at minute 5-6 (T_2), at minute 9-10 (T_3), at minute 16-17 (T_4) . All data were collected for a subject on two days while allowing for adequate rest, at least about 30 minute between each condition were carried out.



Experimental scheme of the study

Subject recruitment

Questionnaires (General health & Physical activities & Sports training)

Physical examination (vital sign at rest)

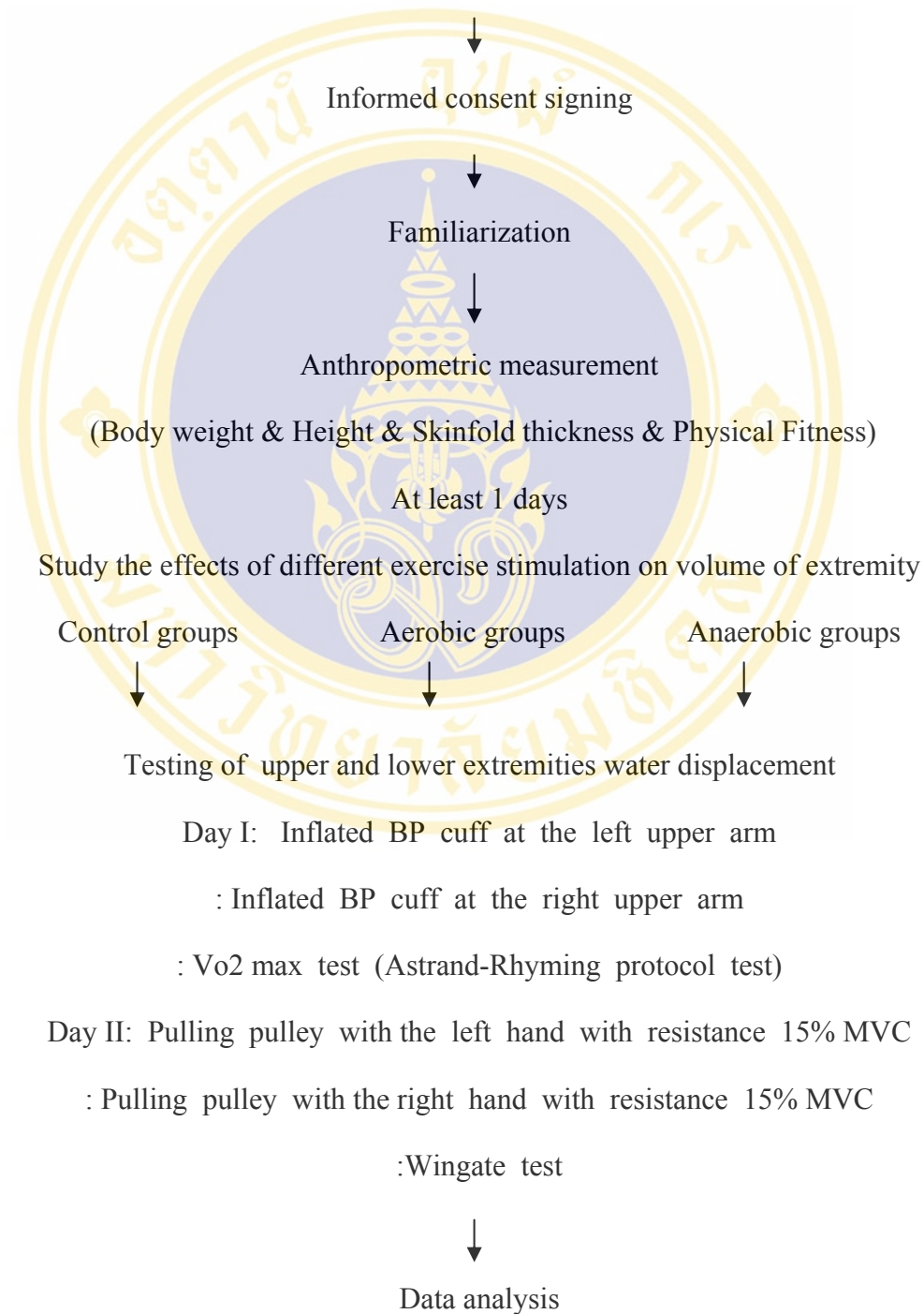

3. Experimental procedure

3.1 Vital Sign

Blood pressure of each subject were measured for by using blood pressure monitor(Model DS-115,Japan), resting heart rate by using Polar(F-PLC, Finland.), body temperature by using Thermometer(Matsuda, Japan), after arriving at the laboratory and rest on a chair for about 10 minutes.

3.2 Anthropometric studies

3.2.1 Body size measurement

Body weight of each subject was measured by using Digital weight balance (AD-6201, Japan). Body Mass Index (BMI) was calculated from ratio of weight (kg) and height (m²). All measurements, using the same equipments, were handled by the same investigator.

3.2.2 Body fat measurement

The skin fold thickness technique was used for determining of body fat by skin fold caliper (F-LSC, England). Body density was calculated based on Jackson and Pollock's equations (42) and Brozek *et al.*'s equation for calculation of percent body fat.

$$D_b = 1.10938 - 0.0008267(x_1) + 0.0000016(x_2)^2 - 0.0002574(x_5)$$

Equation for male age 18-61 years

D_b = body density

X_1 = sum of triceps brachii, suprailiac and thigh (mm)

X_5 = ages of subjects

$$\text{Percent body fat} = \{(4.57/D_b) - 4.142\} * 100$$

The detail of standardized sites by Lohman (23)

- Triceps brachii: over the mid point of the muscle belly between the olecranon and the tip of acromion, with upper arm hanging vertically and loosely.
- Suprailiac: just above the iliac crest in the mid axillary line.
- Thigh: over mid point between inguinal crease and patella

3.3 Muscle strength measurements

Isometric handgrip strength was measured by using digital handgrip dynamometer (Takei & Company, Japan). The subject was asked to perform to grip with a relaxed standing and hold the dynamometer both right and left hand, which the dynamometer was adjusted to a comfortable grip. The subject was asked to squeeze the handles with as much force as possible. The best of three attempts was recorded (coefficient of variation < 10%) (Elkin, 2000).

Isometric muscle strength of back extensor and knee extensor (Quadriceps femoris muscle) were measured by back and leg dynamometer (Takei & Company, Japan). First, the subject was asked to perform to measure the leg strength by asking the subject to stand with a squat position at approximately degree of leg bending and straight back on the dynamometer. The hand bar was adjusted to comfortable pull, then the subject was asked to pull the hand bar with fully extend elbows and back, with maximum effort. Three trials were performed and the highest value was recorded (coefficient of variation < 10%).

Next, the subject was asked to perform to measure the back strength. The subject was asked to stand on the dynamometer and bending forward with fully extend knee. The hand bar was adjusted for comfortable to pull, then subject was asked to pull the hand bar with fully extend elbows and knees with maximum effort, three trials were performed and the highest back strength was recorded (coefficient of variation < 10%).

3.4 Flexibility and Agility test

Flexibility was measured by Sit and Reach Box (Sports Science Program, Rajabhat Loei University). The subject was asked to perform by relaxed long sitting and hold the position. The subject was asked to stretch the body toward together with as much force as possible. The best reach in centimeter of the three attempts was recorded.

Agility was measured by nine square test. The subject was asked to step to the left and do to each corner of the 3x3 slots of nine square (50*50 cm) as much speed as possible into 10 seconds, in the right step the same as the left step. The summation of the right and the left values was calculated as agility index.

3.5 Anaerobic power and capacity test

Anaerobic power and capacity was determined by Wingate 30 second test. Anaerobic power and capacity of each subject was measured by using bicycle ergometer (Monark 828E, Sweden). Before testing, the procedure was explained to each subject until full familiarity was achieved. The subject was asked to perform to relaxed sitting on bicycle. The subject was asked to spin a wheel that increased load with as much force as possible into 30 seconds. Anaerobic power and capacity values were recorded and calculated. (24, 55)

3.6 Maximum Oxygen Consumption (VO₂ max)

VO₂ max was determined by using a bicycle ergometer (Monark 828E, Sweden). Before testing the procedure was explained to each subject until full familiarity was achieved. The subject was asked to perform to relaxed sitting on bicycle. Subjects were performed a maximal oxygen consumption test calculated from submaximal exercise with Astrand-Rhyming protocol test. (24, 39)

3.7 Extremities volume measurement

Extremities volume were measured by displacing water filled in a volumeter (Biomedical Equipment Technology, Mahidol University). Volumeter's size was 27 cm of diameter and 83 cm of height, the out of flow's size was 3 cm of wide and 15 cm of long. The procedures for water displacement volume of the upper and lower extremities were demonstrated and practiced by the subject before water was added to the volumeter. The volumeter was filled with water to the level of the overflow spout, and the water was allowed to stabilize prior to reading the water temperature and beginning the immersion. Water temperature for both the upper and lower extremities measurements was maintained at room temperature 25°C. For the upper extremities measurements, subjects were instructed to lower the arm slowly into the volumeter and to stop when the top of the volumeter came in contact with the elbow (head of radius). At this point, a label line that determined the depth of immersion for repeated measurements was marked by magic marker on the skin of the subject. In the both hands immersion in water 2 minute continuously. For the lower extremities measurements, subjects were instructed to lower the leg slowly into the volumeter and

to stop when the top of the volumeter came in contact with the knee (3/4 of length from malleolus to joint line of the knee). At this point, a label line that determined the depth of immersion for accurate repetition of immersions was marked with a magic marker. The subject immersed the extremities into the volumeter, stopping at the preset label line. The displaced water was weighed on analog weight machine (Pennsylvania Scale Company) this previously prepared computation gave an accurate measurement of the water volume (liter) displaced and recorded.

3.8 Reliability of volumeter

Volumeter made from Biomedical Equipment Technology, Mahidol University. Volumeter's size was 27 cm of diameter and 83 cm of height. Test reliability in 24 subjects. Forearm and leg were immersed in volumeter for measure volume two times. All data were collected for a subject on the same day while allowing adequate time of rest, at least about 30 minutes between each time. Pearson correlation coefficient (r) equal 0.8 ($p < 0.05$) shown that volumeter have high reliability.

The flow of water (H_2O) in 20 seconds intervals after immerse arm and leg in 2 minutes in volumeter is shown in Figure 19A (at Appendix A), it can be seen that there is high out flow in first 20 seconds and slowly decrease afterwards until 120 seconds. Figure 19B (at Appendix A), it can be seen that at 40 seconds, water (H_2O) flow slowly and decrease almost zero at 120 seconds.

3.9 Statistics

All data are presented as mean \pm SEM. A repeated measure ANOVA was used to determine whether or not there was a statistically significant difference between the mean values obtained before and after the conditions period within the same subject. An analysis of variance (ANOVA) was applied to individual variables in order to investigate differences between aerobic groups anaerobic groups and control groups. A Scheffe test was applied to compare the mean values. Data were presented in raw data, percent change of volume per body weight. All the statistical tested were performed by using the SPSS for window versions 10 program. The level of

significance for differences between groups or between time intervals was set at $p < 0.05$.



CHAPTER 4

RESULTS

The physical characteristics of the subjects in the control group, aerobic group (long distance runners) and anaerobic group (short distance runners) are shown in Table 2. The average values of age, body weight, and height of the control group were 19.42 ± 0.52 yr, 60.25 ± 6.78 kg, 167.83 ± 5.60 cm, respectively; the aerobic group were 21.14 ± 0.77 yr, 62.46 ± 7.70 kg, 169.79 ± 5.62 cm, respectively; and those for the anaerobic group were 20.79 ± 0.70 yr, 61.84 ± 5.96 kg, 171.29 ± 4.80 cm, respectively. Their average heart rate, systolic blood pressure, diastolic blood pressure and body mass index were 82 ± 7.27 bpm; 118.08 ± 5.09 mmHg, 71.25 ± 7.94 mmHg, 21.71 ± 2.92 kg.m⁻², respectively for the control group; 70.71 ± 4.87 bpm, 117.60 ± 12.47 mmHg, 67.07 ± 6.94 mmHg, 21.72 ± 2.36 kg.m⁻², for the aerobic group, respectively; and 72.57 ± 9.90 bpm, 119 ± 10.2 mmHg, 71.93 ± 6.66 mmHg, 21.04 ± 1.68 kg.m⁻², for the anaerobic group, respectively. Their average anaerobic power and maximal oxygen consumption of the control group were 7.68 ± 1.09 watt/kg, 36.21 ± 2.56 ml/kg/min, respectively; for the aerobic group were 11.08 ± 1.03 watt/kg, 50.58 ± 4.05 ml/kg/min, respectively; and for the anaerobic group were 15.57 ± 0.91 watt/kg, 44.38 ± 2.29 ml/kg/min, respectively.

Both aerobic and anaerobic groups had significantly lower in heart rate compared to control group ($p < 0.05$). Aerobic group had significantly higher in maximal oxygen consumption compared to control group ($p < 0.01$). Anaerobic group had significantly higher in maximal oxygen consumption compared to control group ($p < 0.05$). Aerobic group had significantly higher in maximal oxygen consumption compared to anaerobic group ($p < 0.01$). Both aerobic and anaerobic groups had significantly higher in anaerobic power compared to control group ($p < 0.01$). Anaerobic groups had significantly higher in anaerobic power compared to aerobic group ($p < 0.01$). No significant differences in age, weight, systolic blood pressure,

diastolic blood pressure and body mass index between the three subject groups ($p>0.05$).

Table 2 General Characteristics of control subjects, aerobic athletes (long distance runners) and anaerobic athletes (short distance runners) used in this study

Parameter	Control (n=12)	Aerobics group(n=14)	Anaerobics group(n=14)
Age (yr)	19.42 ±0.52	21.14 ± 0.77	20.79 ± 0.70
Height (cm)	167.83 ±5.60	169.79 ± 5.62	171.29 ± 4.80
Weight (kg)	60.25±6.78	62.46 ± 7.70	61.84 ± 5.96
HR (bpm)	82±7.27	70.71 ± 4.87*	72.57 ± 9.90*
Sys BP (mmHg)	118.08 ± 5.09	117.60 ± 12.47	119 ± 10.20
Dias BP (mmHg)	71.25 ± 7.94	67.07 ± 6.94	71.93 ± 6.66
BMI (kg/m ²)	21.71 ± 2.92	21.72± 2.36	21.04 ± 1.68
VO ₂ (ml/kg/min)	36.21 ± 2.56	50.58 ± 4.05**	44.38± 2.29** #
Wingate (watt/kg)	7.68 ±1.09	11.08 ±1.03**	15.57 ± 0.91** #

Values are mean±SEM. HR, Heart Rate; Sys Bp, Systolic Blood pressure; Dias Bp, Diastolic Blood pressure; BMI, Body Mass Index; VO₂ Max, Maximal Oxygen consumption; Wingate, Anaerobic power. Significant difference from control; * $p<0.05$; ** $p<0.01$. Significant difference from aerobic group; # $p<0.01$

The mean values of volume of arms and legs in different condition : First, inflated blood pressure cuff at left upper arm , immersion left arm in water condition; the mean values of left arm volume per body weight (Figure 1A) showed no significant differences between the three groups of subjects at all time. The mean values of the left arm percent volume change per body weight (Figure 1B) showed anaerobic group had significantly higher at minute 17th compared to the aerobic and control group ($p<0.05$) Second, , inflated blood pressure cuff at right upper arm , immersion the left arm in water condition; the mean values of the left arm volume per body weight (Figure 2A) showed aerobic group and anaerobic group had significantly higher at minute 17th compared to the control group ($p<0.05$).

The mean values of the left arm percent volume change per body weight (Figure 2B) showed no significant differences between the three groups of subjects at all time. Third, pull pulley the left hand with resistance 15 % maximum voluntary contraction (MVC) , immersion the left arm in water condition ; the mean values of the left arm volume per body weight (Figure 3A) showed no significant differences between the three groups of subjects at all time. The mean values of the left arm percent volume change per body weight (Figure 3B) showed no significant differences between the three groups of subjects at all time. Fourth, pull pulley the right hand with resistance 15 % maximum voluntary contraction (MVC) , immersion the left arm in water condition ; the mean values of the left arm volume per body weight (Figure 4A) showed no significant differences between the three groups of subjects at all time. The mean values of the left arm percent volume change per body weight (Figure 4B) showed no significant differences between the three groups of subjects at all time. Fifth, Vo₂ max test (Astrand – Rhyming test), immersion the left, right arms and left , right legs in water condition ; the mean values of the left arm volume per body weight (Figure 5A) shown no significant differences between the three groups of subjects at all time. The mean values of the left arm percent volume change per body weight (Figure 5B) shown no significant differences between the three groups of subjects at all time. The mean values of the right arm volume per body weight (Figure 6A) shown no significant differences between the three groups of subjects at all time. The mean values of the right arm percent volume change per body weight (Figure 6B) shown no significant differences between the three groups of subjects at all time. The mean values of the left leg volume per body weight (Figure 7A) showed no significant differences between the three groups of subjects at all time. The mean values of the left leg percent volume change per body weight (Figure 7B) showed no significant differences between the three groups of subjects at all time. The mean values of the right leg volume per body weight (Figure 8A) showed aerobic group had significantly higher at pre test compared to the control group ($p < 0.05$). The mean values of the right leg percent volume change per body weight (Figure 8B) showed aerobic group showed significantly lower volume at minute 10th compared to the control group ($p < 0.05$). Finally, Wingate test,

immersion the left, right arms and left, right legs in water condition; the mean values of the left arm volume per body weight (Figure 9A) showed aerobic group had significantly higher at immediately post test compared to the control group ($p < 0.05$). The mean values of the left arm percent volume change per body weight (Figure 9B) showed no significant differences between the three groups of subjects at all time. The mean values of the right arm volume per body weight (Figure 10A) showed aerobic and anaerobic group had significantly higher at minute 10th compared to the control group ($p < 0.05$) but at minute 17th, aerobic group had significantly higher compared to the control group ($p < 0.05$). The mean values of the right arm percent volume change per body weight (Figure 10B) shown no significant differences between the three groups of subjects at all time. The mean values of the left leg volume per body weight (Figure 11A) showed aerobic group had significantly higher at pre test and immediately post-test compared to the control group ($p < 0.05$). The mean values of the left leg percent volume change per body weight (Figure 11B) shown no significant differences between the three groups of subjects at all time. The mean values of the right leg volume per body weight (Figure 12A) showed aerobic group had significantly higher at pre test, immediately post-test, minute 10th, minute 17th compared to the control group ($p < 0.05$). The mean values of the right leg percent volume change per body weight (Figure 12B) showed no significant differences between the three groups of subjects at all time.

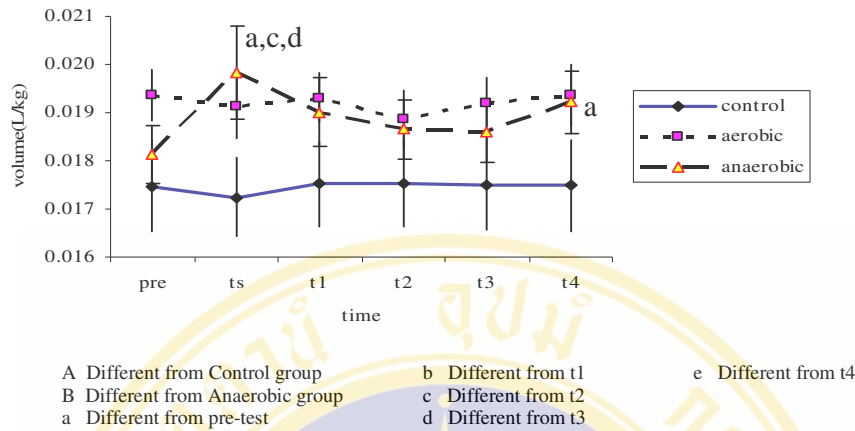

Figure 1A Comparison of the left arm volume per body weight and the left arm pre and post volume per body weight in inflated blood pressure cuff at the left upper arm condition present by mean \pm SEM, statistical comparison shown were One Way ANOVA and repeated measure ANOVA. Pre=pre-test, ts = during stimulation test, t1=immediately post-test, t2=post-test at minute 6th, t3=post-test at minute 10th, t4=post-test at minute 17th ae=Aerobic groups, an=Anaerobic groups. Significant value $p < 0.05$, each interval=2minute

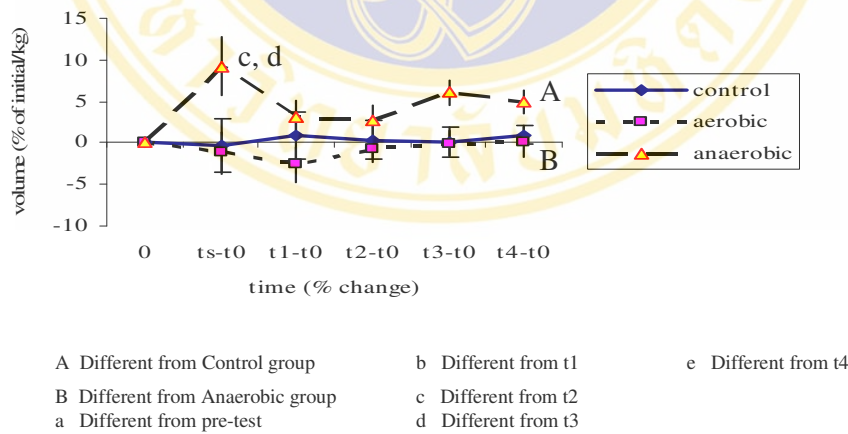
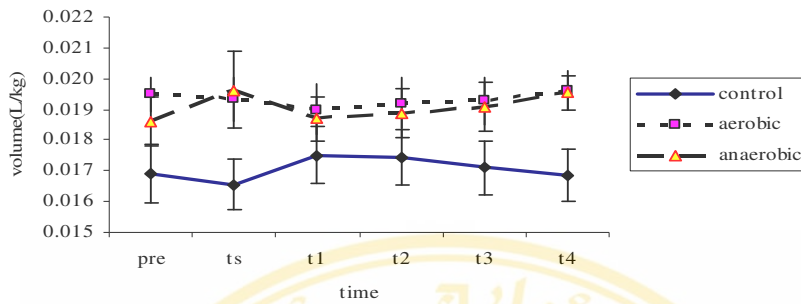
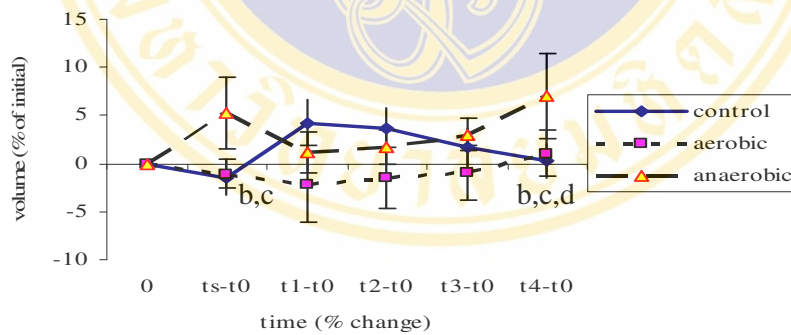

Figure 1B Comparison of the left arm percent volume change per body weight and the left arm pre and post percent volume change per body weight in inflated blood pressure cuff at the left upper arm condition present by mean \pm SEM, statistical comparison shown were One Way ANOVA and repeated measure ANOVA. Pre=pre-test, ts = during stimulation test, t1=immediately post-test, t2=post-test at minute 6th, t3=post-test at minute 10th, t4=post-test at minute 17th ae=Aerobic groups, an=Anaerobic groups. Significant value $p < 0.05$, each interval=2minute



A Different from Control group b Different from t1 e Different from t4
 B Different from Anaerobic group c Different from t2
 a Different from pre-test d Different from t3

Figure 2A Comparison of the left arm volume per body weight and the left arm pre and post volume per body weight in inflated blood pressure cuff at the right upper arm condition present by mean ± SEM, statistical comparison shown were One Way ANOVA and repeated measure ANOVA. Pre=pre-test, ts = during stimulation test, t1=immediately post-test, t2=post-test at minute 6th, t3=post-test at minute 10th, t4=post-test at minute 17th ae=Aerobic groups, an=Anaerobic groups. Significant value p<0.05,each interval=2minute



A Different from Control group b Different from t1 e Different from t4
 B Different from Anaerobic group c Different from t2
 a Different from pre-test d Different from t3

Figure 2B Comparison of the left arm percent volume change per body weight and the left arm pre and post percent volume change per body weight in inflated blood pressure cuff at the right upper arm condition present by mean ± SEM, statistical comparison shown were One Way ANOVA and repeated measure ANOVA. Pre=pre-test, ts = during stimulation test, t1=immediately post-test, t2=post-test at minute 6th, t3=post-test at minute 10th, t4=post-test at minute 17th ae=Aerobic groups, an=Anaerobic groups. Significant value p<0.05, each interval=2minute

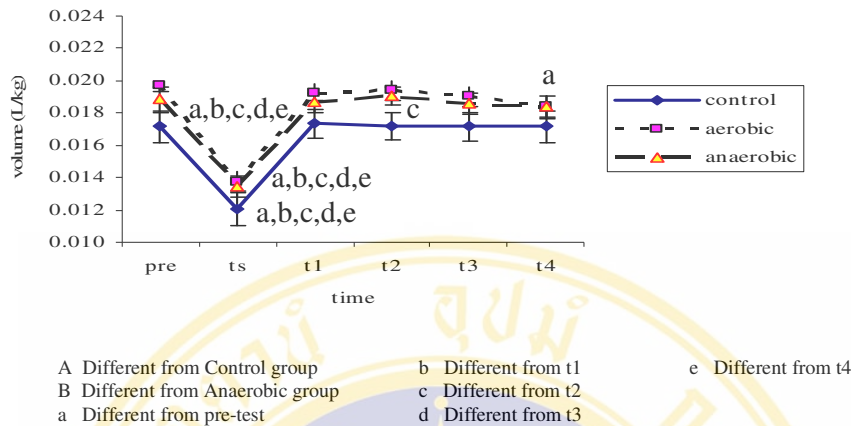

Figure 3A Comparison of the left arm volume per body weight and the left arm pre and post volume per body weight in pull pulley by left hand with resistance 15% maximal voluntary contraction (MVC) condition present by mean ± SEM, statistical comparison shown were One Way ANOVA and repeated measure ANOVA. Pre=pre-test, ts = during stimulation test, t1=immediately post-test, t2=post-test at minute 6th, t3=post-test at minute 10th, t4=post-test at minute 17th ae=Aerobic groups, an=Anaerobic groups. Significant value p<0.05, each interval=2minute

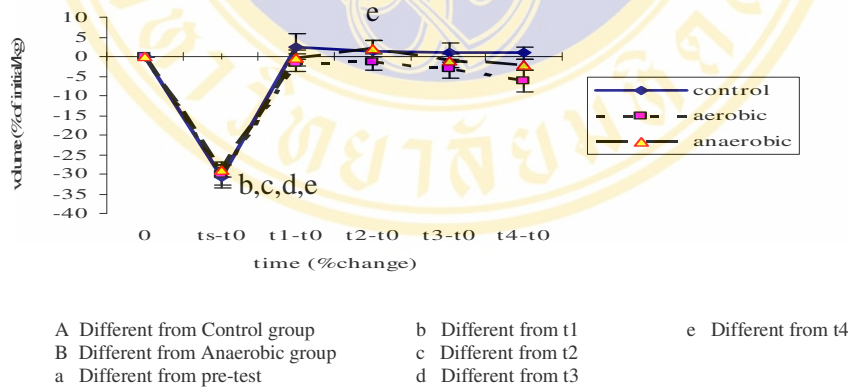
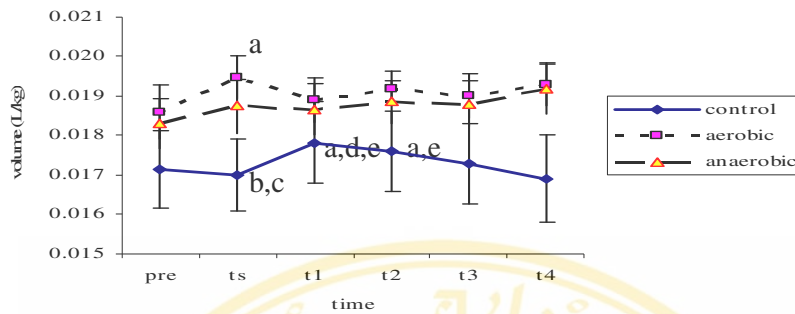
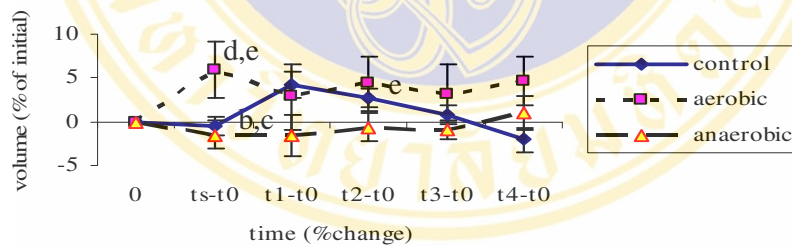

Figure 3B Comparison of the left arm percent volume change per body weight and the left arm pre and post percent volume change per body weight in pull pulley by left hand with resistance 15% maximal voluntary contraction(MVC)condition present by mean ± SEM, statistical comparison shown were One Way ANOVA and repeated measure ANOVA. Pre=pre-test, ts = during stimulation test, t1=immediately post-test, t2=post-test at minute 6th, t3=post-test at minute 10th, t4=post-test at minute 17th ae=Aerobic groups, an=Anaerobic groups. Significant value p<0.05,each interval=2minute



A Different from Control group b Different from t1 e Different from t4
 B Different from Anaerobic group c Different from t2
 a Different from pre-test d Different from t3

Figure 4A Comparison of the left arm volume per body weight and the left arm pre and post volume per body weight in pull pulley by right hand with resistance 15% maximal voluntary contraction(MVC)condition present by mean ± SEM, statistical comparison shown were One Way ANOVA and repeated measure ANOVA. Pre=pre-test, ts= during stimulation test, t1=immediately post-test, t2=post-test at minute 6th, t3=post-test at minute 10th, t4=post-test at minute 17th ae=Aerobic groups, an=Anaerobic groups. Significant value p<0.05, each interval=2minute



A Different from Control group b Different from t1 e Different from t4
 B Different from Anaerobic group c Different from t2
 a Different from pre-test d Different from t3

Figure 4B Comparison of the left arm percent volume change per body weight and the left arm pre and post percent volume change per body weight in pull pulley by right hand with resistance 15% maximal voluntary contraction(MVC)condition present by mean ± SEM, statistical comparison shown were One Way ANOVA and repeated measure ANOVA. Pre=pre-test, ts = during stimulation test, t1 = immediately post-test, t2 = post-test at minute 6th, t3 = post-test at minute 10th, t4 = post-test at minute 17th ae = Aerobic groups, an = Anaerobic groups. Significant value p < 0.05, each interval=2minute

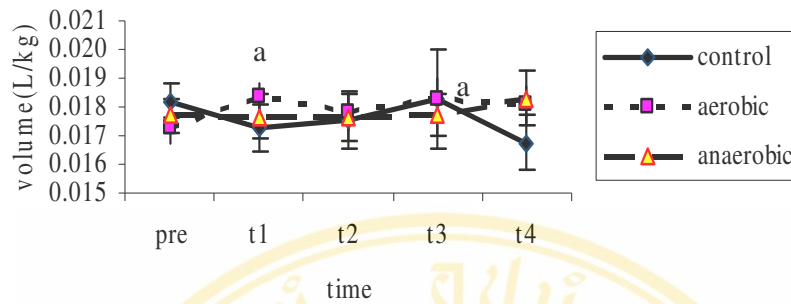

A Different from Control group b Different from t1 e Different from t4
 B Different from Anaerobic group c Different from t2
 a Different from pre-test d Different from t3

Figure 5A Comparison of the left arm volume per body weight and the left arm pre and post volume per body weight in VO2 max test (Astrand- Rhyming test) condition present by mean ± SEM, statistical comparison shown were One Way ANOVA and repeated measure ANOVA. Pre=pre-test, t1=immediately post-test, t2=post-test at minute 6th, t3=post-test at minute 10th, t4=post-test at minute 17th ae=Aerobic groups, an=Anaerobic groups. Significant value p<0.05, each interval=2minute

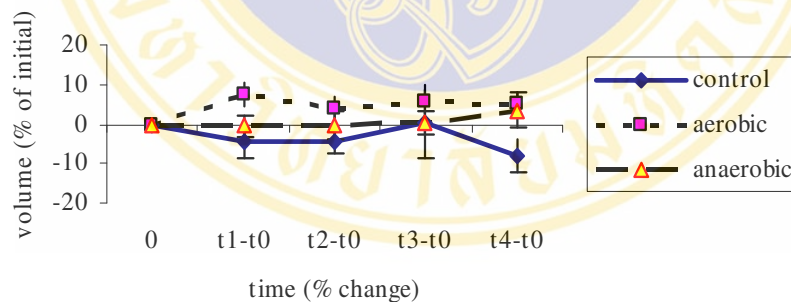

A Different from Control group b Different from t1 e Different from t4
 B Different from Anaerobic group c Different from t2
 a Different from pre-test d Different from t3

Figure 5B Comparison of the left arm percent volume change per body weight and the left arm pre and post percent volume change per body weight in VO2 max test (Astrand- Rhyming test) condition present by mean ± SEM, statistical comparison shown were One Way ANOVA and repeated measure ANOVA. Pre=pre-test, t1=immediately post-test, t2=post-test at minute 6th, t3=post-test at minute 10th, t4=post-test at minute 17th ae=Aerobic groups, an=Anaerobic groups. Significant value p<0.05, each interval=2minute

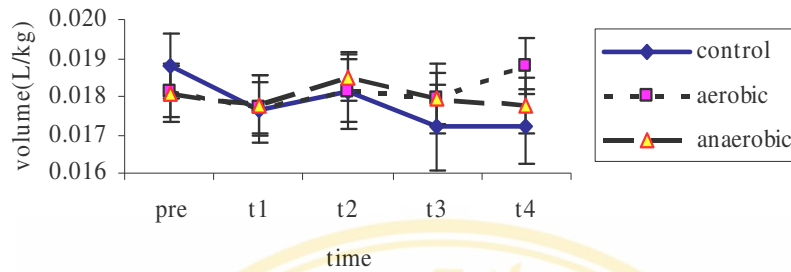

A Different from Control group b Different from t1 e Different from t4
 B Different from Anaerobic group c Different from t2
 a Different from pre-test d Different from t3

Figure 6A Comparison of the right arm volume per body weight and the right arm pre and post volume per Body weight in VO2 max test (Astrand- Rhyming test) condition present by mean \pm SEM, statistical comparison shown were One Way ANOVA and repeated measure ANOVA. Pre=pre-test, t1=immediately post-test, t2=post-test at minute 6th, t3=post-test at minute 10th, t4=post-test at minute 17th ae=Aerobic groups, an=Anaerobic groups. Significant value $p < 0.05$, each interval=2minute

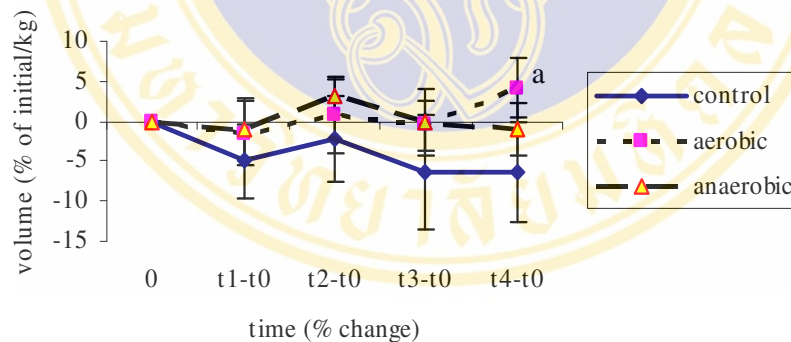

A Different from Control group b Different from t1 e Different from t4
 B Different from Anaerobic group c Different from t2
 a Different from pre-test d Different from t3

Figure 6B Comparison of the right arm percent volume change per body weight and the right arm pre and post percent volume change per body weight in VO2 max test (Astrand- Rhyming test) condition present by mean \pm SEM, statistical comparison shown were One Way ANOVA and repeated measure ANOVA. Pre=pre-test, t1=immediately post-test, t2=post-test at minute 6th, t3=post-test at minute 10th, t4=post-test at minute 17th ae=Aerobic groups, an=Anaerobic groups. Significant value $p < 0.05$, each interval=2minute

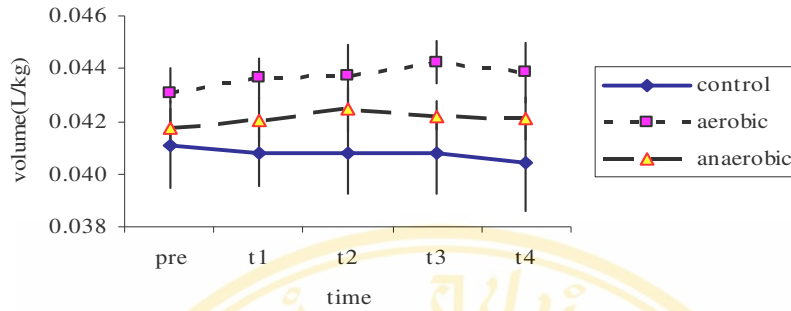

A Different from Control group b Different from t1 e Different from t4
 B Different from Anaerobic group c Different from t2
 a Different from pre-test d Different from t3

Figure 7A Comparison of the left leg volume per body weight and the left leg pre and post volume per body weight in VO₂ max test (Astrand- Rhyming test) condition present by mean ± SEM, statistical comparison shown were One Way ANOVA and repeated measure ANOVA. Pre=pre-test, t1=immediately post-test, t2=post-test at minute 6th, t3=post-test at minute 10th, t4=post-test at minute 17th ae=Aerobic groups, an=Anaerobic groups. Significant value p<0.05, each interval=2minute

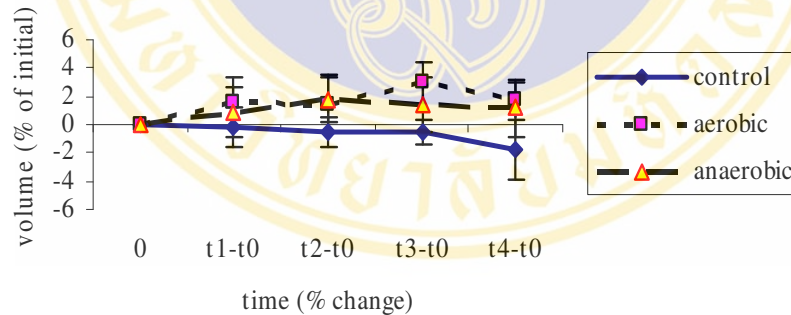

A Different from Control group b Different from t1 e Different from t4
 B Different from Anaerobic group c Different from t2
 a Different from pre-test d Different from t3

Figure 7B Comparison of the left leg percent volume change per body weight and the left leg pre and post percent volume change per body weight in VO₂ max test (Astrand- Rhyming test) condition present by mean ± SEM, statistical comparison shown were One Way ANOVA and repeated measure ANOVA. Pre=pre-test, t1=immediately post-test, t2=post-test at minute 6th, t3=post-test at minute 10th, t4=post-test at minute 17th ae=Aerobic groups, an=Anaerobic groups. Significant value p<0.05, each interval=2minute

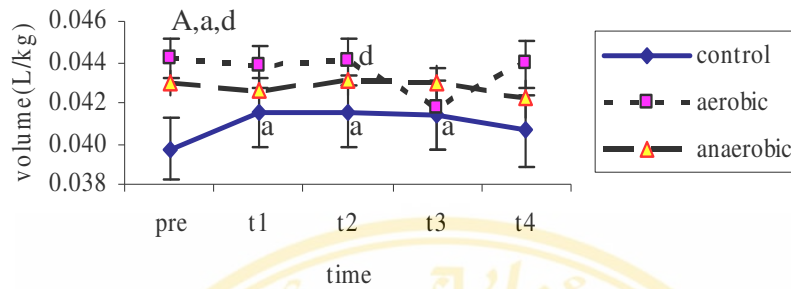

A Different from Control group b Different from t1 e Different from t4
 B Different from Anaerobic group c Different from t2
 a Different from pre-test d Different from t3

Figure 8A Comparison of the right leg volume per body weight and the right leg pre and post volume per body weight in VO2 max test (Astrand- Rhyming test) condition present by mean ± SEM, statistical comparison shown were One Way ANOVA and repeated measure ANOVA. Pre=pre-test, t1=immediately post-test, t2=post-test at minute 6th, t3=post-test at minute 10th, t4=post-test at minute 17th ae=Aerobic groups, an=Anaerobic groups. Significant value p<0.05, each interval=2minute

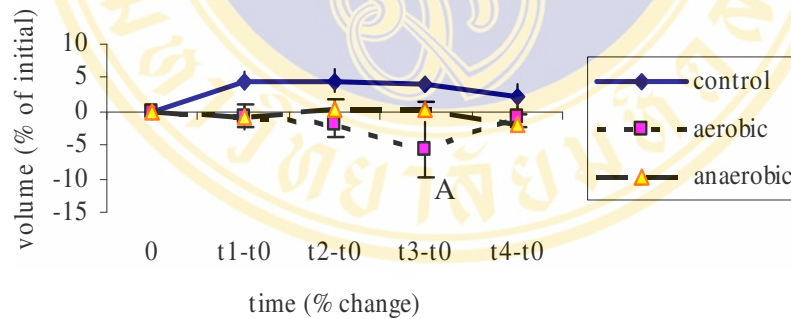

A Different from Control group b Different from t1 e Different from t4
 B Different from Anaerobic group c Different from t2
 a Different from pre-test d Different from t3

Figure 8B Comparison of the right leg percent volume change per body weight and the right leg pre and post percent volume change per body weight in VO2 max test (Astrand- Rhyming test) condition present by mean ± SEM, statistical comparison shown were One Way ANOVA and repeated measure ANOVA. Pre=pre-test, t1=immediately post-test, t2=post-test at minute 6th, t3=post-test at minute 10th, t4=post-test at minute 17th ae=Aerobic groups, an=Anaerobic groups. Significant value p<0.05, each interval=2minute

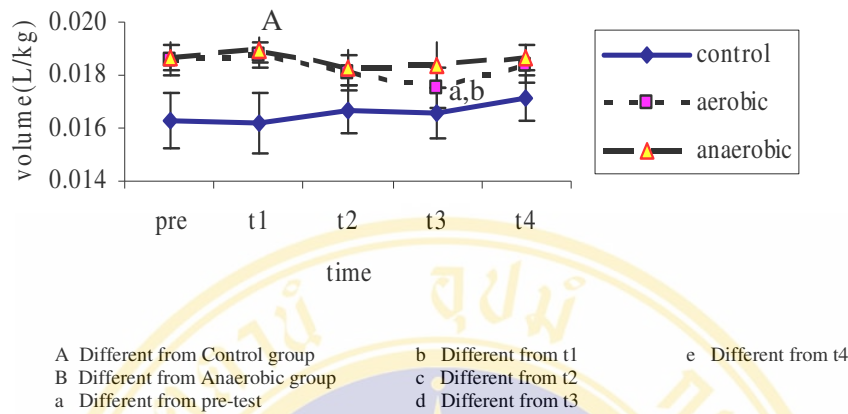

Figure 9A Comparison of the left arm volume per body weight and the left arm pre and post volume per body weight in Wingate test condition present by mean \pm SEM, statistical comparison shown were One Way ANOVA and repeated measure ANOVA. Pre=pre-test, t1=immediately post-test, t2=post-test at minute 6th, t3=post-test at minute 10th, t4=post-test at minute 17th ae=Aerobic groups, an=Anaerobic groups. Significant value $p < 0.05$, each interval=2minute

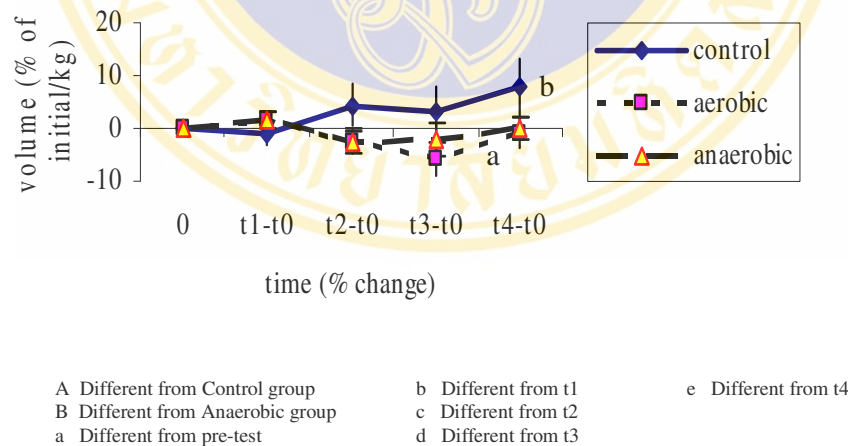
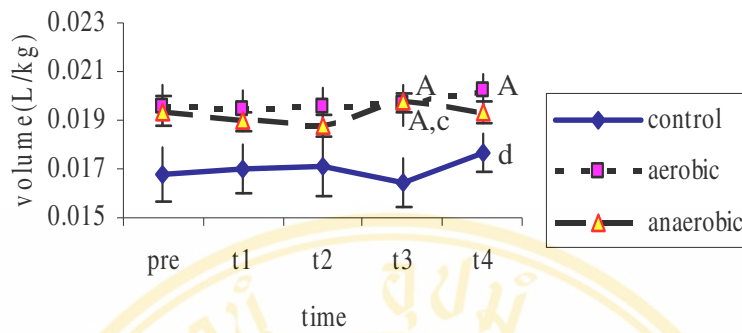
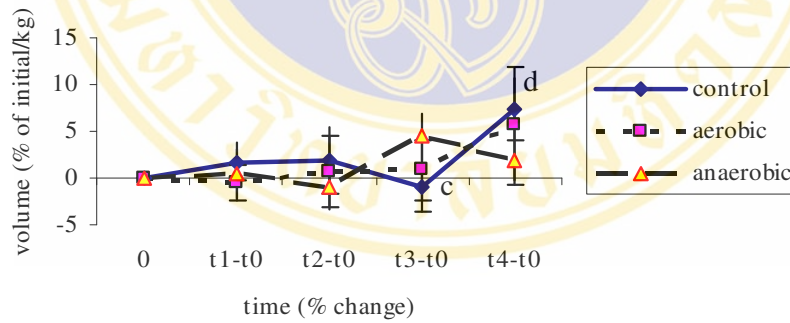

Figure 9B Comparison of the left arm percent volume change per body weight and the left arm pre and post percent volume change per body weight in Wingate test condition present by mean \pm SEM, statistical comparison shown were One Way ANOVA and repeated measure ANOVA. Pre=pre-test, t1=immediately post-test, t2=post-test at minute 6th, t3=post-test at minute 10th, t4=post-test at minute 17th ae=Aerobic groups, an=Anaerobic groups. Significant value $p < 0.05$, each interval=2minute



A Different from Control group b Different from t1 e Different from t4
 B Different from Anaerobic group c Different from t2
 a Different from pre-test d Different from t3

Figure 10A Comparison of the right arm volume per body weight and the right arm pre and post volume per body weight in Wingate test condition present by mean ± SEM, statistical comparison shown were One Way ANOVA and repeated measure ANOVA. Pre=pre-test, t1=immediately post-test, t2=post-test at minute 6th, t3=post-test at minute 10th, t4=post-test at minute 17th ae=Aerobic groups, an=Anaerobic groups. Significant value p<0.05, each interval=2minute



A Different from Control group b Different from t1 e Different from t4
 B Different from Anaerobic group c Different from t2
 a Different from pre-test d Different from t3

Figure 10B Comparison of the right arm percent volume change per body weight and the right arm pre and post percent volume change per body weight in Wingate test condition present by mean ± SEM, statistical comparison shown were One Way ANOVA and repeated measure ANOVA. Pre=pre-test, t1=immediately post-test, t2=post-test at minute 6th, t3=post-test at minute 10th, t4=post-test at minute 17th ae=Aerobic groups, an=Anaerobic groups. Significant value p<0.05, each interval=2minute

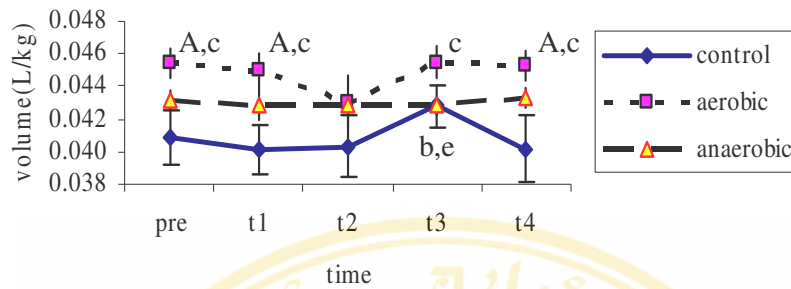

A Different from Control group b Different from t1 e Different from t4
 B Different from Anaerobic group c Different from t2
 a Different from pre-test d Different from t3

Figure 11A Comparison of the left leg volume per body weight and the left leg pre and post volume per body weight in Wingate test condition present by mean ± SEM, statistical comparison shown were One Way ANOVA and repeated measure ANOVA. Pre=pre-test, t1=immediately post-test, t2=post-test at minute 6th, t3=post-test at minute 10th, t4=post-test at minute 17th ae=Aerobic groups, an=Anaerobic groups. Significant value p<0.05, each interval=2minute

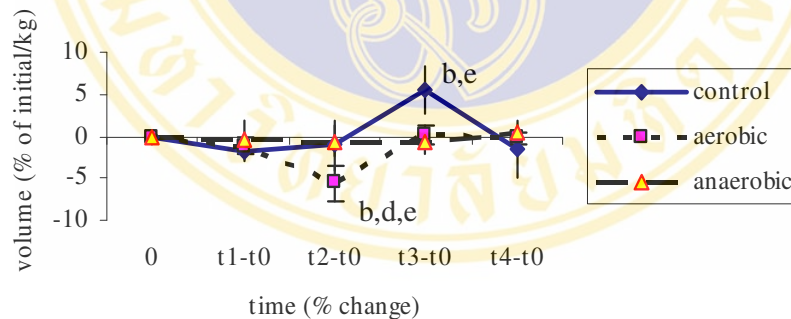

A Different from Control group b Different from t1 e Different from t4
 B Different from Anaerobic group c Different from t2
 a Different from pre-test d Different from t3

Figure 11B Comparison of the left leg percent volume change per body weight and the left leg pre and post percent volume change per body weight in Wingate test condition present by mean ± SEM, statistical comparison shown were One Way ANOVA and repeated measure ANOVA. Pre=pre-test, t1=immediately post-test, t2=post-test at minute 6th, t3=post-test at minute 10th, t4=post-test at minute 17th ae=Aerobic groups, an=Anaerobic groups. Significant value p<0.05, each interval=2minute

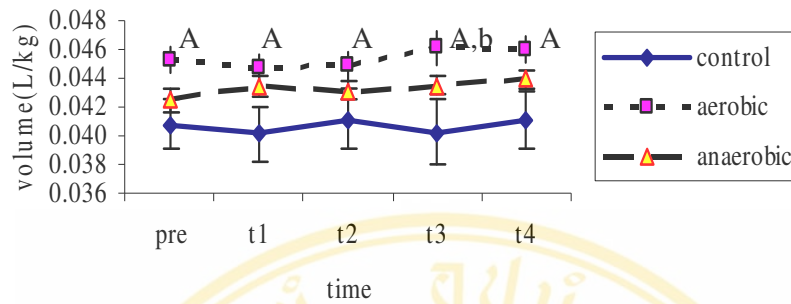

A Different from Control group
 B Different from Anaerobic group
 a Different from pre-test
 b Different from t1
 c Different from t2
 d Different from t3
 e Different from t4

Figure 12A Comparison of the right leg volume per body weight and the right leg pre and post volume per body weight in Wingate test condition present by mean \pm SEM, statistical comparison shown were One Way ANOVA and repeated measure ANOVA. Pre=pre-test, t1=immediately post-test, t2=post-test at minute 6th, t3=post-test at minute 10th, t4=post-test at minute 17th ae=Aerobic groups, an=Anaerobic groups. Significant value $p < 0.05$, each interval=2minute

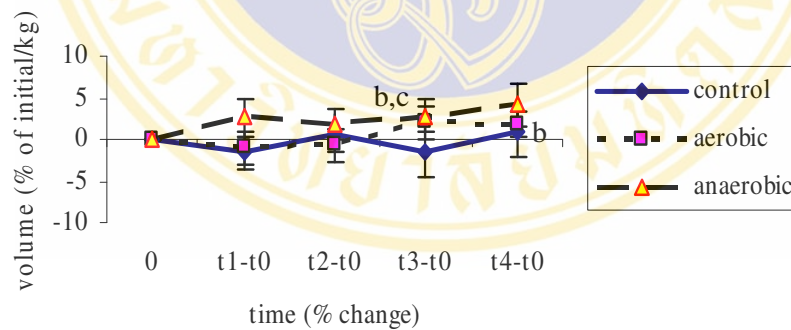

A Different from Control group
 B Different from Anaerobic group
 a Different from pre-test
 b Different from t1
 c Different from t2
 d Different from t3
 e Different from t4

Figure 12B Comparison of the right leg percent volume change per body weight and the right leg pre and post percent volume change per body weight in Wingate test condition present by mean \pm SEM, statistical comparison shown were One Way ANOVA and repeated measure ANOVA. Pre=pre-test, t1=immediately post-test, t2=post-test at minute 6th, t3=post-test at minute 10th, t4=post-test at minute 17th ae=Aerobic groups, an=Anaerobic groups. Significant value $p < 0.05$, each interval=2minute

The comparison of arms and legs volume pre and post test in repeated measure ANOVA method in same condition, result showed that; First, inflated blood pressure cuff at the left upper arm, immersion the left arm in water condition; values of the left arm pre and post volume per body weight (Figure 1A) showed that the control and aerobic groups had no significant differences between pre and post test of the same subjects at all time, in anaerobic group had significantly higher at during test compared to pre test, minute 6th and minute 10th ($p < 0.05$), at minute 17th significantly higher compared to pre test ($p < 0.05$). Whereas values of the left arm pre and post percent volume change (Figure 1B) showed that the control and aerobic groups had no significant differences between pre and post test of the same subjects at all time, in anaerobic group found significantly higher at during test compared to minute 6th and minute 10th ($p < 0.05$).

Second condition, inflated blood pressure cuff at the right upper arm, immersion the left arm in water condition; values of the left arm pre and post volume per body weight (Figure 2A) showed that the control group found significantly higher at immediately post test compared to during test and minute 17th ($p < 0.05$), at minute 6th significantly higher compared at during test ($p < 0.05$), in aerobic and anaerobic groups no significant differences between pre and post test of the same subjects at all time. Whereas values of the left arm pre and post percent volume change (Figure 2B) shown control group found significantly higher at the immediately post test compared to during test and minute 17th ($p < 0.05$), at minute 6th significantly higher compared to that at during test and minute 17th ($p < 0.05$), aerobic and anaerobic groups had no significant differences between pre and post test of the same subjects at all time.

Third condition, pull pulley with the left hand with resistance 15 % maximum voluntary contraction (MVC), immersion the left arm in water condition; values of the left arm pre and post volume per body weight (Figure 3A) showed that the control group had significantly higher at pre test, post test all time compared to during test ($p < 0.05$), in aerobic group found significantly higher at pre test, post test all time compared to during test ($p < 0.05$), at pre test significantly higher compared to that at minute 17th ($p < 0.05$), at minute 6th significantly higher compared to that at minute 17th ($p < 0.05$), in anaerobic group found significantly

higher at pre test , post test all time compared to during test ($p<0.05$), at minute 6th significantly higher compared to that at minute 17th ($p<0.05$). Whereas values of the left arm pre and post percent volume change (Figure 3B) showed that the control group had significantly higher at post test all time compared to during test ($p<0.05$), in aerobic group found significantly higher at post test all time compared to during test ($p<0.05$), at minute 6th significantly higher compared to that at minute 17th ($p<0.05$), in anaerobic group found significantly higher at post test all time compared to during test ($p<0.05$), at minute 6th significantly higher compared to that at minute 17th ($p<0.05$).

Fourth condition, pull pulley with the right hand with resistance 15 % maximum voluntary contraction (MVC) , immersion the left arm in water condition ; values of the left arm pre and post volume per body weight (Figure 4A) showed that the control group found at immediately post - test had significantly higher compared to that at pre test, during test , minute 10th and minute 17th ($p<0.05$), at minute 6th significantly higher compared to that at pre test, during test and minute 17th ($p<0.05$), in aerobic group found at during test significantly higher compared to that at pre test ($p<0.05$), in anaerobic group found no significant differences between pre and post test of the same subjects at all time. Whereas values of the left arm pre and post percent volume change (Figure 4B) showed that the control group had significantly higher at immediately post - test compared to that at during test , minute 10th and minute 17th ($p<0.05$), at minute 6th significantly higher compared to that at minute 10th and minute 17th ($p<0.05$), in aerobic and anaerobic groups found no significant differences between pre and post test of the same subjects at all time.

Fifth condition, Vo2 max test (Astrand – Rhyming test), immersion the left, right arms and the left , right legs in water condition ; values of the left arm pre and post volume per body weight (Figure 5A) showed that the control and anaerobic groups showed no significant differences between pre and post test of the same subjects at all time, in aerobic group showed significantly lower at the pre test compared immediately with the post test and minute 10th ($p<0.05$). Whereas values of the left arm pre and post percent volume change (Figure 5B) showed that the

control group, aerobic group and anaerobic group no significant differences between pre and post test of the same subjects at all time.

Values of the right arm pre and post volume per body weight (Figure 6A) showed that the control, aerobic and anaerobic groups had no significant differences between pre and post test of the same subjects at all time. Whereas values of the left arm pre and post percent volume change (Figure 6B) showed that the control group and anaerobic group had no significant differences between pre and post test of the same subjects at all time, in aerobic group it was significantly higher at minute 17th compared to the immediately post – test ($p<0.05$).

Values of the left leg pre and post volume per body weight (Figure 7A) and values of the left leg pre and post percent volume change (Figure 7B) showed that the control, aerobic and anaerobic groups had no significant differences between pre and post test of the same subjects at all time.

Values of the right leg pre and post volume per body weight (Figure 8A) showed that the control group found significantly lower at the pre test compared with the immediately post – test, minute 6th and minute 10th ($p<0.05$), in aerobic group found significantly lower at minute 10th compared pre test and minute 6th ($p<0.05$), in anaerobic group had no significant differences between pre and post test of the same subjects at all time. Whereas values of the left arm pre and post percent volume change (Figure 8B) showed that the control group, aerobic group and anaerobic group had no significant differences between pre and post test of the same subjects at all time.

Finally, Wingate test, immersion of the left, right arms and left, right legs in water condition ; values of the left arm pre and post volume per body weight (Figure 9A) showed that control group and anaerobic group had no significant differences between pre and post test of the same subjects at all time , in aerobic group found significantly lower at minute 10th compared to the pre test and immediately post - test ($p<0.05$). Whereas values of the left arm pre and post percent volume change (Figure 9B) showed that the control group found significantly higher at minute 17th compared to the immediately post - test ($p<0.05$), in aerobic group found significantly higher at minute 10th compared to the pre test ($p<0.05$), in

anaerobic group had no significant differences between pre and post test of the same subjects at all time.

Values of the right arm pre and post volume per body weight (Figure 10A) and values of the right arm pre and post percent volume change (Figure 10B) showed that the control group found significantly higher at minute 17th compared to the minute 10th ($p < 0.05$), in aerobic groups had no significant differences between pre and post test of the same subjects at all time, in anaerobic group found significantly higher at minute 10th compared to minute 6th ($p < 0.05$).

Values of the left leg pre and post volume per body weight (Figure 11A) showed that the control group found significantly higher at the minute 10th compared to the immediately post – test compared to pre test ($p < 0.05$), and minute 17th ($p < 0.05$), in aerobic group found significantly lower at minute 6th compared to the pre test, immediately post - test, minute 10th and minute 17th ($p < 0.05$), in anaerobic group found significantly higher at minute 17th compared to the pre test ($p < 0.05$). Whereas values of the left leg pre and post percent volume change (Figure 11B) showed that the control group found significantly higher at minute 10th compared to immediately post - test and minute 17th ($p < 0.05$), in aerobic group found significantly lower at minute 6th compared to immediately post - test, minute 10th and minute 17th ($p < 0.05$), in anaerobic group had no significant differences between pre and post test of the same subjects at all time.

Values of the right leg pre and post volume per body weight (Figure 12A) showed that the control and anaerobic groups had no significant differences between pre and post test of the same subjects at all time, in aerobic group found significantly higher at minute 10th compared to the immediately post – test ($p < 0.05$). Whereas values of the right leg pre and post percent volume change (Figure 12B) showed that the control and anaerobic groups had no significant differences between pre and post test of the same subjects at all time, in aerobic group it was found that there was significantly higher at the minute 10th compared to immediately post – test and minute 6th ($p < 0.05$), at minute 17th had significantly higher compared to the immediately post – test ($p < 0.05$)

The comparison of the heart rate between groups in different conditions : Firstly, inflated blood pressure cuff at the left upper arm , immersion the left arm in water condition; values of the heart rate (Figure 13A) showed no significant differences in all group of subject at all time. Secondly, inflated blood pressure cuff at the right upper arm , immersion the left arm in water condition; values of the heart rate (Figure14A) showed that the control and aerobic groups found significantly lower compared to the anaerobic group at pre test ($p<0.05$), aerobic and anaerobic groups had significantly higher at minute 10th compared to the control group ($p<0.05$), anaerobic group had significantly higher at minute 17th compared to the control group ($p<0.05$). Thirdly, pull pulley with the left hand with resistance 15 % maximum voluntary contraction (MVC) , immersion the left arm in water condition ; values of the heart rate (Figure 15A) showed that the aerobic and anaerobic groups had significantly higher at immediately post – test compared to the control group ($p<0.05$) anaerobic group had significantly higher at minute 17th compared to the control group($p<0.05$). Fourthly, pulling pulley with the right hand with resistance 15 % maximum voluntary contraction (MVC) , immersion the left arm in water condition ; values of the heart rate (Figure 16A) showed that the anaerobic group had significantly higher at minute 6th compared to the aerobic group ($p<0.05$), control and anaerobic groups had significantly lower at minute 10th compared to the aerobic group ($p<0.05$), the control group had significantly higher at minute 17th compared to the aerobic group ($p<0.05$). Fifthly, the Vo₂ max test (Astrand – Rhyding test), immersion the left, right arms and left , right legs in water condition ; the values of the heart rate (Figure 17A) showed that the control and anaerobic groups had significantly higher heart rate at immediately post – test compared to the aerobic group ($p<0.05$), the control group had significantly higher heart rate at minute 6th compared to the aerobic group ($p<0.05$), control and anaerobic groups had significantly higher heart rate at minute 17th compared to the aerobic group ($p<0.05$). Finally, Wingate test, immersion the left, right arms and left , right legs in water condition ; values of the heart rate (Figure 18A) showed that the aerobic and anaerobic groups had significantly higher heart rate at immediately post – test compared to the control

group ($p < 0.05$), control and aerobic groups had significantly lower heart rate at minute 6th, minute 10th and minute 17th compared to the anaerobic group ($p < 0.05$).

The comparison of the heart rate in pre and post test in repeated measure ANOVA method in the same condition, the result shown that; Firstly, inflated blood pressure cuff at the left upper arm, immersion the left arm in water condition; values of the heart rate (Figure 13B) of control group was significantly lower at minute 17th compared to the pre test, during test, immediately post-test, minute 6th and minute 10th ($p < 0.05$), at minute 10th significantly higher heart rate compared to the immediately post-test and minute 6th ($p < 0.05$), in aerobic group showed no significantly in every time, in anaerobic group found to be significantly lower heart rate at minute 6th and minute 17th compared to pre-test, immediately post-test and minute 10th ($p < 0.05$). Second condition, inflated blood pressure cuff at the right upper arm, immersion the left arm in water condition; values of heart rate (Figure 14B) showed that the control group was significantly lower heart rate at pre test compared to minute 6th ($p < 0.05$), at immediately post-test significantly higher heart rate at pre test, minute 10th and minute 17th ($p < 0.05$), at during test, minute 6th and minute 17th significantly higher heart rate at minute 10th ($p < 0.05$), in aerobic group found significantly higher at immediately post-test compared to pre test, minute 6th, minute 10th and minute 17th ($p < 0.05$), in anaerobic group found significantly higher heart rate at pre-test compared to minute 10th and minute 17th ($p < 0.05$), at immediately post-test significantly higher heart rate compared to minute 6th, minute 10th and minute 17th ($p < 0.05$). Thirdly condition, pull pulley with the left hand with resistance 15 % maximum voluntary contraction (MVC), immersion the left arm in water condition; values of the heart rate (Figure 15B) showed that the control group was significantly higher heart rate at pre -test, during test, minute 6th and minute 17th compared to the immediately post-test ($p < 0.05$), at minute 17th significantly higher compared minute 6th and minute 10th ($p < 0.05$), in aerobic group found at minute 17th significantly lower heart rate compared to pre -test, immediately post-test, minute 6th and minute 10th ($p < 0.05$), at pre -test significantly higher heart rate compared to during test ($p < 0.05$), in anaerobic group found significantly higher heart rate at pre-test compared to minute 6th, minute 10th and minute 17th ($p < 0.05$), at immediately post-test significantly higher heart rate compared to minute 10th and

minute 17th ($p < 0.05$), at during test significantly higher heart rate compared to minute 6th, minute 10th and minute 17th ($p < 0.05$). Fourthly, pull pulley with the right hand with resistance 15 % maximum voluntary contraction (MVC), immersion the left arm in water condition; values of the heart rate (Figure 16B) showed that the control group found significantly higher heart rate at during test compared to minute 6th and minute 10th ($p < 0.05$), at pre test, immediately post-test significantly higher heart rate compared to the minute 10th ($p < 0.05$), at minute 17th significantly higher heart rate compared to pre-test, during test, immediately post-test, minute 6th and minute 10th ($p < 0.05$), in aerobic group found significantly higher at pre-test, during test, immediately post-test, minute 6th and minute 10th compared to minute 17th ($p < 0.05$), at pre test significantly higher heart rate compared to immediately post-test and minute 6th ($p < 0.05$), at minute 10th significantly higher heart rate compared to pre test, immediately post-test and minute 6th ($p < 0.05$), at during test had significantly higher heart rate compared to immediately post-test and minute 6th ($p < 0.05$), in anaerobic group found significantly higher heart rate at pre-test, during test, immediately post-test, minute 6th compared to minute 10th ($p < 0.05$), at pre test significantly higher heart rate compared to immediately post-test, minute 6th and minute 17th ($p < 0.05$), at during test significantly higher heart rate compared to immediately post-test, minute 6th and minute 17th ($p < 0.05$). Fifthly, Vo₂ max test (Astrand – Rhyming test), immersion the left, right arms and left, right legs in water condition; values of the heart rate (Figure 17B) the control group found significantly lower heart rate at pre-test compared to immediately post-test, minute 6th, minute 10th and minute 17th ($p < 0.05$), at immediately post-test significantly higher heart rate compared to minute 6th, minute 10th and minute 17th ($p < 0.05$), at minute 6th significantly higher heart rate compared to minute 10th and minute 17th, at minute 10th significantly higher heart rate compared to minute 17th ($p < 0.05$), in aerobic group found significantly higher heart rate at immediately post-test compared to pre-test, minute 6th, minute 10th and minute 17th ($p < 0.05$), at minute 6th significantly higher heart rate compared to pre test, and minute 17th ($p < 0.05$), at minute 10th significantly higher heart rate compared to pre test and minute 17th ($p < 0.05$), in anaerobic group found significantly lower heart rate at pre-test compared to immediately post-test, minute 6th and minute 10th and minute 17th ($p < 0.05$), at immediately post-test significantly higher heart rate compared to

minute 6th, minute 10th and minute 17th ($p < 0.05$), at minute 6th significantly higher heart rate compared to minute 10th and minute 17th ($p < 0.05$). Finally, Wingate test, immersion the left, right arms and left, right legs in water condition; values of the heart rate (Figure 18B) showed that the control group found significantly higher heart rate at immediately post-test compared to pre-test, minute 6th, minute 10th and minute 17th ($p < 0.05$), at minute 6th significantly higher heart rate compared to pre-test, minute 10th and minute 17th ($p < 0.05$), at minute 10th significantly higher heart rate compared to minute 17th ($p < 0.05$), at pre-test significantly higher heart rate compared to minute 17th ($p < 0.05$), in aerobic group found significantly higher at immediately post-test compared to pre-test, minute 6th, minute 10th and minute 17th ($p < 0.05$), at minute 6th significantly higher heart rate compared to pre-test, minute 10th and minute 17th ($p < 0.05$), at minute 10th significantly higher heart rate compared to minute 17th ($p < 0.05$), anaerobic group found significantly lower heart rate at pre-test compared to immediately post-test, minute 6th, minute 10th and minute 17th ($p < 0.05$), at minute 6th significantly higher heart rate compared to minute 10th and minute 17th ($p < 0.05$), at minute 10th significantly higher heart rate compared to minute 17th ($p < 0.05$).

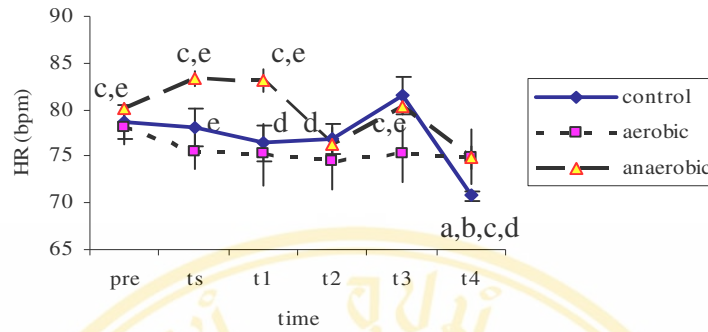

A Different from Control group b Different from t1 e Different from t4
 B Different from Anaerobic group c Different from t2
 a Different from pre-test d Different from t3

Figure 13A Comparison of heart rate and pre and post heart rate in inflated blood pressure cuff at the left upper arm condition present by mean ± SEM, statistical comparison shown were One Way ANOVA and repeated measure ANOVA. pre=pre-test, ts=during stimulation test, t1=immediately post-test, t2=post-test at minute 6, t3=post-test at minute 12,ae=Aerobic groups, an=Anaerobic groups. Significant value p<0.05, each interval=2minute

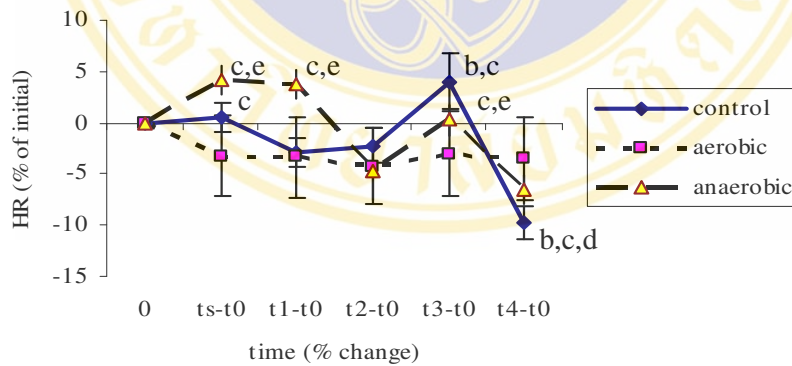

A Different from Control group b Different from t1 e Different from t4
 B Different from Anaerobic group c Different from t2
 a Different from pre-test d Different from t3

Figure 13B Comparison of percent change of HR and percent change of HR pre-post test in inflated blood pressure cuff at the left upper arm condition present by mean ± SEM, statistical comparison shown were One Way ANOVA and repeated measure ANOVA. pre=pre-test, ts=during stimulation test, t1=immediately post-test, t2=post-test at minute 6, t3=post-test at minute 12,ae=Aerobic groups, an=Anaerobic groups. Significant value p<0.05, each interval=2minute

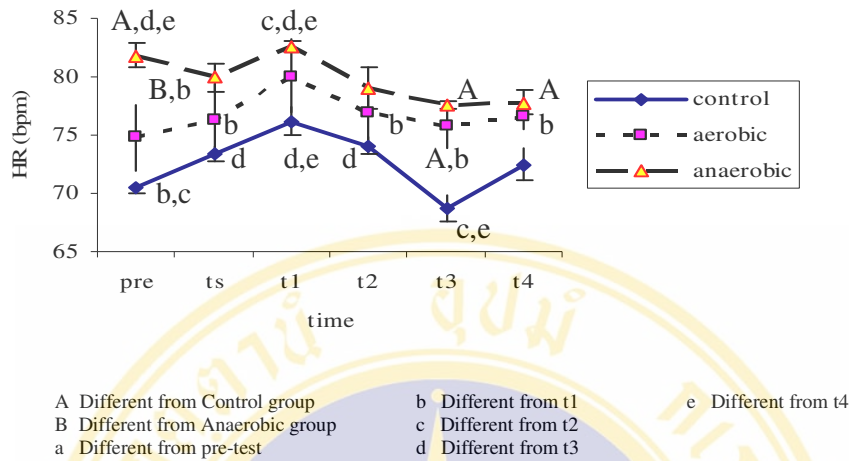

Figure 14A Comparison of heart rate and pre and post heart rate in inflated blood pressure cuff at the right upper arm condition present by mean \pm SEM, statistical comparison shown were One Way ANOVA and repeated measure ANOVA. pre=pre-test, ts=during stimulation test, t1=immediately post-test, t2=post-test at minute 6, t3=post-test at minute 12, ae=Aerobic groups, an=Anaerobic groups. Significant value $p < 0.05$, each interval=2minute

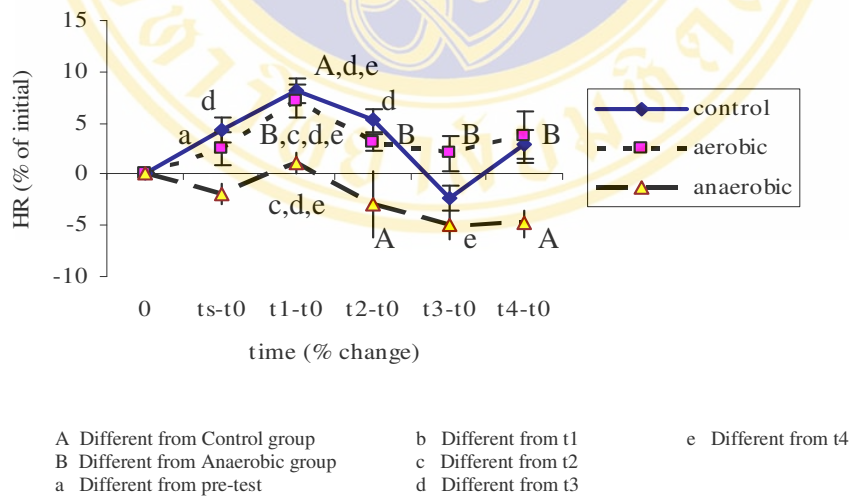

Figure 14B Comparison of percent change of heart rate and percent change of heart rate pre-post test in inflated blood pressure cuff at the right upper arm condition present by mean \pm SEM, statistical comparison shown were One Way ANOVA repeated measure ANOVA. pre=pre-test, ts=during stimulation test, t1=immediately post-test, t2=post-test at minute 6, t3=post-test at minute 12, ae=Aerobic groups, an=Anaerobic groups. Significant value $p < 0.05$, each interval=2minute

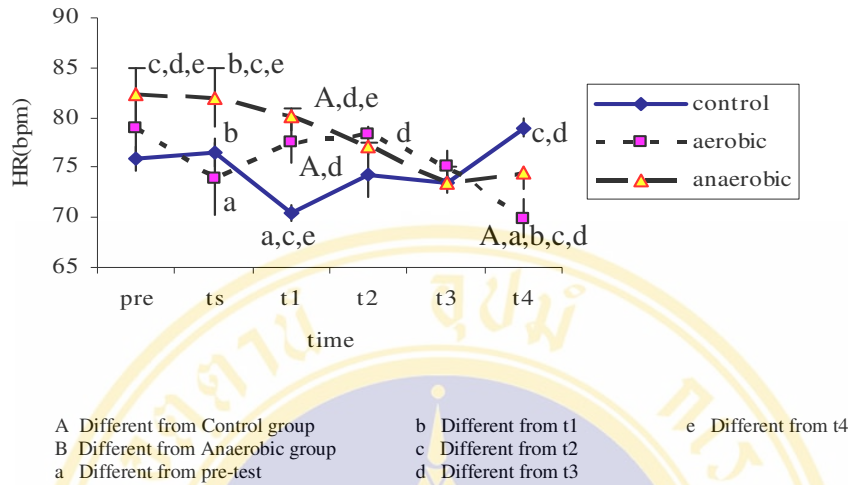

Figure 15A Comparison of heart rate and pre and post heart rate in pulling pulley with the left hand with resistance 15% maximal voluntary contraction (MVC) condition present by mean \pm SEM, statistical comparison shown were One Way ANOVA and repeated measure ANOVA. pre=pre-test, ts=during stimulation test, t1=immediately post-test, t2=post-test at minute 6, t3=post-test at minute 12, ae=Aerobic groups, an=Anaerobic groups. Significant value $p < 0.05$, each interval=2minute

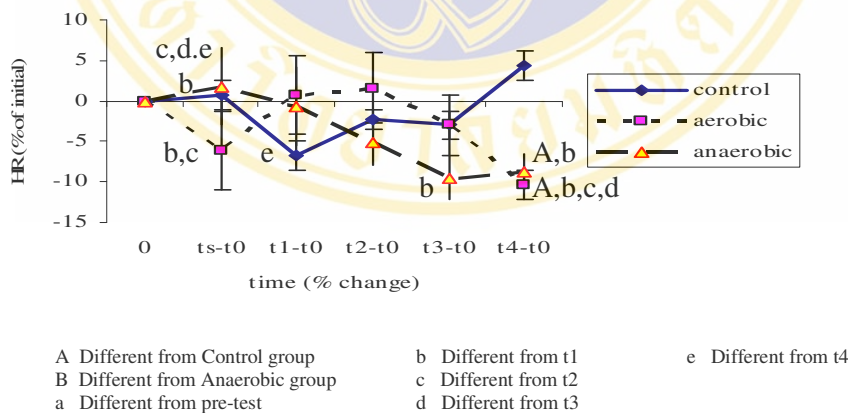

Figure 15B Comparison of percent change of heart rate and percent change of heart rate pre-post test in pulling pulley with the left hand with resistance 15% maximal voluntary contraction (MVC) condition present by mean \pm SEM, statistical comparison shown were One Way ANOVA and repeated measure ANOVA. pre=pre-test, ts=during stimulation test, t1=immediately post-test, t2=post-test at minute 6, t3=post-test at minute 12, ae=Aerobic groups, an=Anaerobic groups. Significant value $p < 0.05$, each interval=2minute

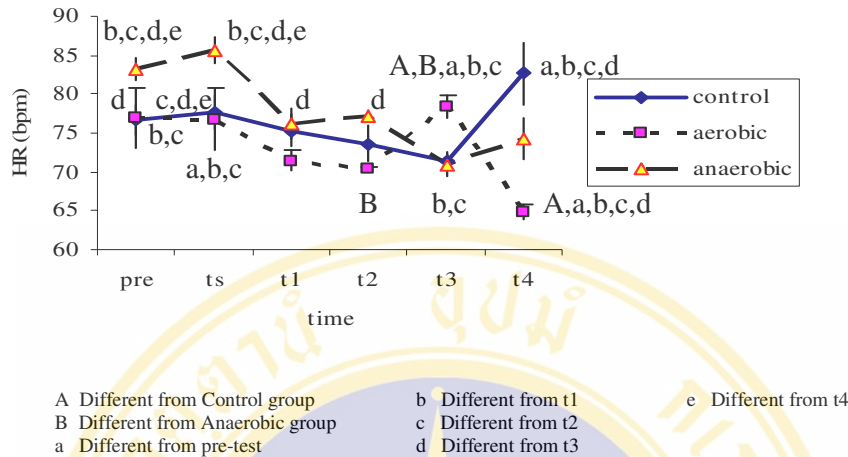

Figure 16A Comparison of heart rate and pre and post heart rate in pulling pulley with the right hand with resistance 15% maximal voluntary contraction (MVC) condition present by mean \pm SEM, statistical comparison shown were One Way ANOVA repeated measure ANOVA. pre=pre-test, ts=during stimulation test, t1=immediately post-test, t2=post-test at minute 6, t3=post-test at minute 12, ae=Aerobic groups, an=Anaerobic groups. Significant value $p < 0.05$, each interval=2minute

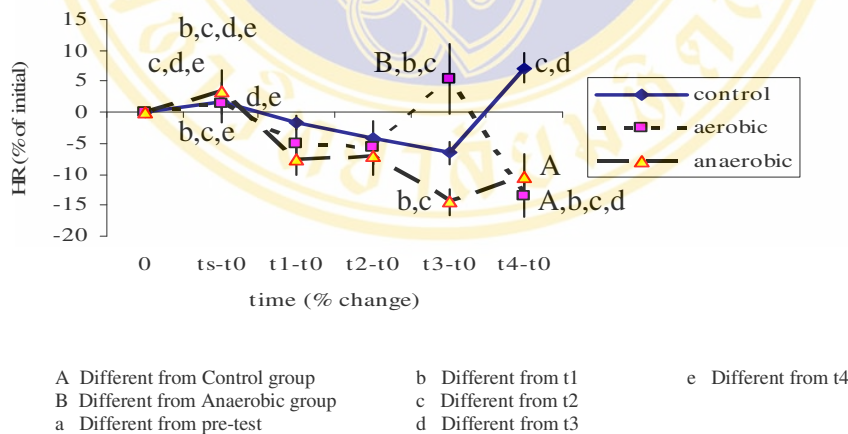

Figure 16B Comparison of percent change of heart rate and percent change of heart rate pre-post test in pulling pulley with the right hand with resistance 15% maximal voluntary contraction (MVC) condition present by mean \pm SEM, statistical comparison shown were One Way ANOVA and repeated measure ANOVA. pre=pre-test, ts=during stimulation test, t1=immediately post-test, t2=post-test at minute 6, t3=post-test at minute 12, ae=Aerobic groups, an=Anaerobic groups. Significant value $p < 0.05$, each interval=2minute

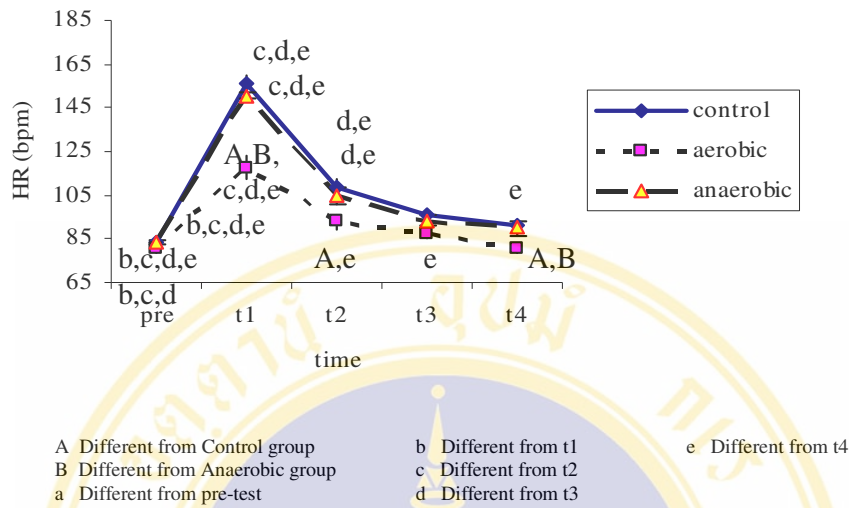

Figure 17A Comparison of heart rate and pre and post heart rate in VO2 max test (Astrand- Rhyming test) condition present by mean ± SEM, statistical comparison shown were One Way ANOVA and repeated measure ANOVA. pre=pre-test, t1=immediately post-test, t2=post-test at minute 6, t3=post-test at minute 12, ae=Aerobic groups, an=Anaerobic groups. Significant value p<0.05, each interval=2minute

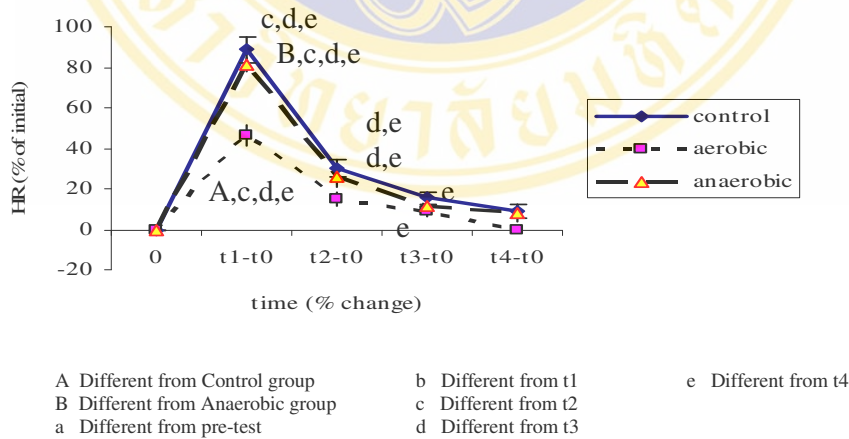

Figure 17B Comparison of percent change of heart rate and percent change of heart rate pre-post test in VO2 max test (Astrand- Rhyming test) condition present by mean ± SEM, statistical comparison shown were One Way ANOVA and repeated measure ANOVA. pre=pre-test, t1=immediately post-test, t2=post-test at minute 6, t3=post-test at minute 12, ae=Aerobic groups, an=Anaerobic groups. Significant value p<0.05, each interval=2minute

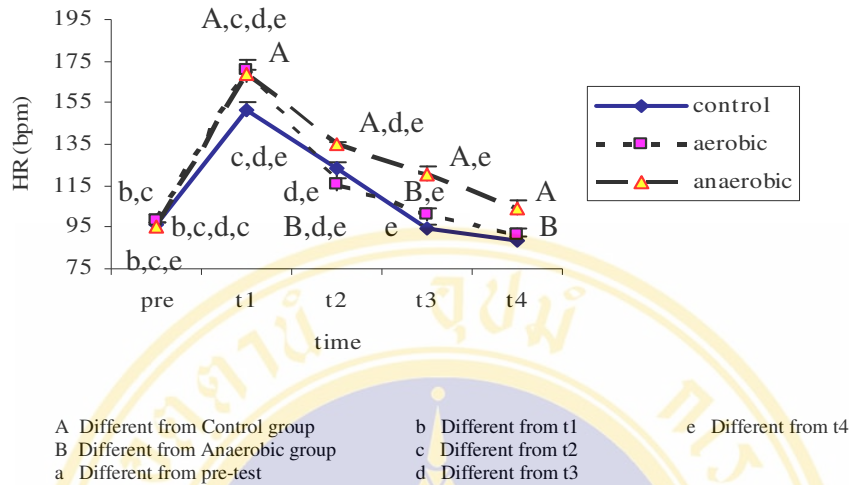

Figure 18A Comparison of heart rate and pre and post heart rate in Wingate test condition present by mean ± SEM, statistical comparison shown were One Way ANOVA and repeated measure ANOVA. pre=pre-test, t1=immediately post-test, t2=post-test at minute 6, t3=post-test at minute 12, ae=Aerobic groups, an=Anaerobic groups. Significant value $p < 0.05$, each interval=2minute

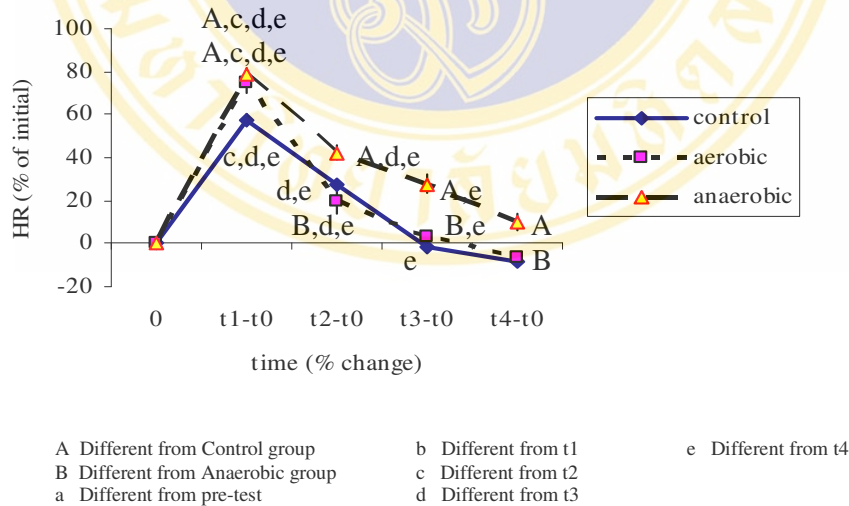

Figure 18B Comparison of percent change of heart rate and percent change of heart rate pre-post test in Wingate test condition present by mean ± SEM, statistical comparison shown were One Way ANOVA and repeated measure ANOVA. pre=pre-test, t1=immediately post-test, t2=post-test at minute 6, t3=post-test at minute 12, ae=Aerobic groups, an=Anaerobic groups. Significant value $p < 0.05$, each interval=2minute

The comparison percent change of heart rate between group in different condition: Firstly, inflated blood pressure cuff at the left upper arm , immersion left arm in water condition; values of the heart rate (Figure 13B) shown no significantly differences all group of subject at all time. Secondly, inflated blood pressure cuff at the right upper arm , immersion the left arm in water condition; values of the heart rate (Figure 14B) showed that the control and aerobic groups found significantly higher compared to anaerobic group at the immediately post-test and minute 17th ($p<0.05$), control group had significantly higher at minute 6th compared to anaerobic group ($p<0.05$), aerobic group had significantly higher at minute 10th compared to the anaerobic group ($p<0.05$), anaerobic group had significantly higher at during test compared to control group ($p<0.05$), Thirdly, pulling pulley with the left hand with resistance 15 % maximum voluntary contraction (MVC) , immersion the left arm in water condition ; values of the heart rate (Figure 15B) showed that the aerobic and anaerobic groups had significantly lower at minute 17th compared to control group ($p<0.05$). Fourth, pulling pulley with the right hand with resistance 15 % maximum voluntary contraction (MVC) , immersion left arm in water condition ; values of the heart rate (Figure 16B) showed that the aerobic group had significantly higher at minute 10th compared to anaerobic group ($p<0.05$), in aerobic and anaerobic groups had significantly lower at minute 17th compared to control group ($p<0.05$), aerobic group and control group had significantly lower at during test compared to anaerobic group ($p<0.05$). Fifthly, Vo2 max test (Astrand – Rhyming test), immersion the left, right arms and left , right legs in water condition ; values of the heart rate (Figure 17B) showed that the control and anaerobic groups had significantly higher at immediately post – test compared to aerobic group ($p<0.05$). Finally, Wingate test, immersion the left, right arms and left , right legs in water condition ; values of the heart rate (Figure 18B) showed that the aerobic and anaerobic groups had significantly higher at immediately post – test compared to control group ($p<0.05$), control and aerobic groups had significantly lower at minute 6th , minute 10th and minute 17th compared to anaerobic group ($p<0.05$).

The comparison percent change of heart rate in pre and post test in repeated measure ANOVA method in the same condition, the result showed that; First, inflated

blood pressure cuff at left upper arm , immersion the left arm in water condition; values of the heart rate (Figure 13B) of control group found significantly lower at minute 17th compared to during test, immediately post-test, minute 6th and minute 10th ($p<0.05$), at minute 10th significantly higher compared to immediately post-test and minute 6th ($p<0.05$), in aerobic group showed no significantly in every time, in anaerobic group found significantly higher at during test, immediately post-test and minute 10th compared to minute 6th and minute 17th ($p<0.05$). Secondly condition, inflated blood pressure cuff at the right upper arm , immersion the left arm in water condition; values of heart rate (Figure14B) showed that the control group found significantly higher at during test, immediately post-test, minute 6th and minute 17th compared to minute 10th ($p<0.05$), at minute 17th significantly lower compared to immediately post-test ($p<0.05$), in aerobic group found significantly higher at immediately post-test compared to during test, minute 6th, minute 10th and minute 17th ($p<0.05$), in anaerobic group found significantly higher at immediately post-test compared to minute 5th, minute 10th and minute 17th ($p<0.05$). Thirdly condition, pulling pulley with the left hand with resistance 15 % maximum voluntary contraction (MVC) , immersion left arm in water condition ; values of the heart rate (Figure 15B) showed that the control group found at minute 17th significantly higher compared to immediately post-test, minute 6th and minute 10th ($p<0.05$), at during test significantly higher compared to immediately post-test ($p<0.05$), in aerobic group found at minute 17th significantly lower compared to immediately post-test, minute 6th and minute 10th ($p<0.05$), at immediately post-test, minute 16th significantly higher compared to during test($p<0.05$), in anaerobic group found significantly lower at minute 10th, minute 17th compared to immediately post-test ($p<0.05$), at during test significantly higher compared to minute 6th, minute 10th and minute 17th ($p<0.05$). Fourth, pulling pulley with the right hand with resistance 15 % maximum voluntary contraction (MVC) , immersion the left arm in water condition ; values of the heart rate (Figure16B) showed that the control group found significantly higher at immediately post-test compared to minute 10th ($p<0.05$), at minute 17th significantly higher compared to during test, immediately post-test , minute 6th and minute 10th ($p<0.05$), at during test significantly higher compared to minute 6th, minute 10th ($p<0.05$), in aerobic group found at immediately post-test,

minute 6th and minute 10th significantly higher compared to minute 17th ($p < 0.05$), at minute 10th significantly higher compared to immediately post-test and minute 6th ($p < 0.05$), at during test significantly higher compared to immediately post-test, minute 10th minute 17th ($p < 0.05$), in anaerobic group found at minute 10th and minute 17th significantly lower compared to immediately post-test ($p < 0.05$) at during test significantly higher compared to minute 6th, minute 10th minute 17th ($p < 0.05$), Fifthly, Vo₂ max test (Astrand – Rhyming test), immersion the left, right arms and left, right legs in water condition; values of the heart rate (Figure 17B) found the control group found at immediately post-test had significantly higher compared to minute 6th, minute 10th and minute 17th ($p < 0.05$), at minute 6th significantly higher compared to minute 10th and minute 17th, at minute 10th significantly higher compared to minute 17th ($p < 0.05$), in aerobic group found at immediately post-test significantly higher compared to minute 6th, minute 10th and minute 17th ($p < 0.05$), at minute 6th significantly higher compared to minute 10th and minute 17th, at minute 10th significantly higher compared to minute 17th ($p < 0.05$), in anaerobic group found at immediately post-test significantly higher compared to minute 6th, minute 10th and minute 17th ($p < 0.05$), at minute 6th significantly higher compared to minute 10th and minute 17th. Finally, Wingate test, immersion the left, right arms and left, right legs in water condition; values of the heart rate (Figure 18B) found the control group found at immediately post-test significantly higher compared to minute 6th, minute 10th and minute 17th ($p < 0.05$), at minute 6th significantly higher compared to minute 10th and minute 17th, at minute 10th significantly higher compared to minute 17th ($p < 0.05$), in aerobic group found at immediately post-test significantly higher compared to minute 6th, minute 10th and minute 17th ($p < 0.05$), at minute 6th significantly higher compared to minute 10th and minute 17th, at minute 10th significantly higher compared to minute 17th ($p < 0.05$), in anaerobic group found at immediately post-test significantly higher compared to minute 6th, minute 10th and minute 17th ($p < 0.05$), at minute 6th significantly higher compared to minute 10th and minute 17th, at minute 10th significantly higher compared to minute 17th ($p < 0.05$).

CHAPTER 5

DISCUSSION

In this study, the basic physical characteristics of the subjects used, including age, body weight, systolic blood pressure, diastolic blood pressure and body mass index of aerobic group, anaerobic group and the control were similar. Compared to the control, the aerobic group and anaerobic group showed greater of some fitness parameters such as indicated by higher values of maximum oxygen consumption and anaerobic power. There are at least two mechanisms that could explain the performance gain in the aerobic and anaerobic groups. The training could result in the modification of a motor pattern in the central nervous system and biomechanical and physiological change in the muscular tissue. Since aerobic and anaerobic groups are sports event which places a demand on the entire neuromuscular system, the individual differences in speed of reaction and movement are dependent on past neuromuscular uses. In support of this notion, Bhanot and coworkers (1980) (5) compared the reaction times in various groups of athletes and found that the visual and auditory reaction times were shorter in weightlifters than that in gymnast, volleyball and hockey players. A second possibility is that the resistance training could stimulate hypertrophy of skeletal muscle which can shorten the contraction time. It also has been shown that, long term resistance training (>12 wk) increase serum testosterone level which may increase muscle protein synthesis. This, in turn, results in increased in muscle mass and force generation (Vogel, 1985; Hakkinen, 1988) (35,101). Of further interest was the finding that, anaerobic athletes had been shown to have greater fast twitch fiber area than most other athletes as well as sedentary control (Kanehisa, 1999)(51), and resistance training has been shown to induce a greater hypertrophy in type IIA/B fiber than in type I fiber (Staron, 1994; Kraemer, 1995) (61,93). All of these factors may explain why the aerobic and anaerobic groups exhibited greater general fitness than the sedentary subjects. The routine programming for several minutes of daily running of

this group of short runners may also a cause of high aerobic capacity of this group of subjects.

Acute volume of extremities are previously recognized as indirect indicator of alteration of vasomotor by many investigators (6,11,13,36,56). Alterations of volume of extremities can be resulted from different stimulations such as exercise training and thermal exposure. Exercise or training was shown to prevent edema in human (Stick et al., 1992)(8) and cause an elevated vasodilator system (Kellogg et al, 1991)(15). In the present study, we have demonstrated that aerobic athletes also had greater lower extremities initial and stimulated volume and vasodilatation than control subjects in Wingate test condition. At the resting aerobic athletes had lower extremities volume greater than control group in Wingate test condition and in right leg in VO₂ max test condition this may imply that the adaptation of vascular system in the leg in relation to nature and number of use of the muscle on long duration in competition and training lead to higher blood supply to muscle(76). In addition to greater muscle mass, Febbraio and co-worker in 1996 examined the effects of elevated muscle temperature on muscle metabolism during exercise and found that an elevated muscle temperature per se increases muscle glycogenolysis, glycolysis, and high energy phosphate degradation during exercise, these alterations may be the result of an increased rate of ATP turnover associated with the exercise and/or changes in the anaerobic/aerobic contribution to ATP re-synthesis (26). The other studies, Buma et al 1976 showed that long distance runner can tolerate prolong the time period of running until a dangerous body temperature (23). McMurray et al 1979 found that runners were able to attain higher sweat rates and tolerated longer than swimmer in 35°C water (75). Green H.J. et al 1984 found that high exercise intensity can enhance exercise-induced hypervolemia in muscle and that rapid elevation in plasma volume can be induced in training (32). Connelly et al 1990 found that the central shift in blood volume with water immersion reduces the sympathoadrenal response to high intensity dynamic exercise (97). Kellogg et al 1998 found that nitric oxide has a role causing of cutaneous vasodilatation during heat stress (53). In addition, Johnson et al 1982 found that exercise can induce cutaneous vasoconstrictor (44).

In percent volume changes, in the first condition, inflated blood pressure cuff at the left upper arm condition, Between group, the values of the left arm volume shown

no significant difference between the three groups of subjects at all time. When correlated with the heart rate at the same time, it can be seen that there was also no difference all groups of subjects. Within the same group, the volume values of the left arm in the control group found no significant difference in all period. When related with the heart rate at the same time, it can be seen that in minute 17th it had greater decrease in the heart rate than during test, immediately post-test, minute 6th, 10th and 17th, minute 10th had greater increase in the heart rate than immediately post-test, and minute 6th. In aerobic group, the volume values of the left arm found no significant difference in all period. When compared with the heart rate at the same time, it can be seen that there was no significant difference in all period. In the anaerobic group, the volume values of the left arm found at during test had greater vasodilatation than at the minute 6th and minute 10th. When related with the heart rate at the same time, it can be seen that during test, immediately post-test, and minute 10th it had greater increase than minute 6th and minute 17th.

Therefore, there should be no significant change in the sympathetic activity and values of the left arm volume of the three groups of subjects. This may explain that inflated blood pressure cuff at the left upper arm condition may not have much effect on sympathetic activity and in within the same group, the differences in the three groups of subjects, can be used to explain alteration in the vasodilatation of the three groups. This may imply that the degree of vasodilatation of the left arm may be controlled by factors other than neural factors such as hormonal factors or other local substances such as nitric oxide (85, 31, 52, 54, 63, 97).

Second condition, inflated blood pressure cuff at the left upper arm condition, In between group, the values of the left arm volume of aerobic and anaerobic groups had greater vasodilatation at minute 17th than that of the control group. When related with the heart rate at the same time, it can be seen that the anaerobic group had greater increase in the heart rate than the control group at during test, anaerobic group had greater increase in the heart rare than the control and aerobic groups at pre test period, aerobic and anaerobic groups had greater increase in the heart rate than the control group at minute 10th, anaerobic group had greater increase in the heart rare than the control group at minute 17th. Within the same group, the volume values of the left arm in the control group showed that at the immediately post-test and minute 6th had

greater vasodilatation than during test and minute 17th. When related with heart rate at the same time, it can be seen that at minute 10th had greater decrease heart rate than during test, immediately post-test, minute 6th and 17th, at immediately post-test had increase greater than minute 17th. In aerobic and anaerobic groups the volume values of left arm found no significant difference all period. When compared with the heart rate at the same time, it can be seen that at immediately post-test had greater increase in the heart rate than during test, minute 6th, 10th and 17th.

Therefore, it seem to have increase in sympathetic activity of anaerobic trained subject at minute 17th but the values of the left arm volume at the same time in anaerobic trained subject had greater vasodilatation than that of the control group. This may imply that the degree of vasodilatation of arm in anaerobic trained may be controlled by other factors other than neural factors such as hormonal factors or their local tissue substances such as nitric oxide (85, 31, 52, 54, 63, 97)

Third condition is pulling pulley with the left hand with 15% MVC condition. In between group, the values of the left arm volume found no significant difference between the three groups of subjects. When compared with the heart rate at the same time, it can be seen that aerobic and anaerobic groups had greater increase in the heart rate than control group at immediately post-test period, the control group had greater increase in the heart rate than the control group at minute 17th. Within the same group, the volume values of the left arm in the control group showed that at the during test had greater vasoconstriction than immediately post-test, minute 6th, 10th and 17th. This apparent decrease in the left arm volume may be caused by deformation of skin contracting the handle of the weight pulling of the left hand. When related with the heart rate at the same time, it can be seen that during test had greater increase heart rate than immediately post-test, minute 17th had greater increase in the heart rate than immediately post-test, minute 6th and minute 10th. In aerobic group, the volume values of the left arm was similarly control group. When related with the heart rate at the same time, it can be seen that during test it had greater increase in the heart rate than immediately post-test, minute 6th, minute 17th had greater increase heart rate than immediately post-test, minute 6th and minute 10th. In anaerobic group, the volume values of the left arm was similar control group. When related with heart rate at the same time, it can be seen that during test had greater increase heart rate than

immediately post-test, minute 6th, minute 10th and minute 17th, immediately post-test had greater increase heart rate than minute 10th and minute 17th.

Therefore, the increase in sympathetic activity of the aerobic and anaerobic trained subjects but there was no significant change in the values of the left arm volume at the same time. This may explain that pulling pulley with the left hand with 15% MVC condition may be too weak to stimulate sympathetic activity and in within the same group found values of the left arm volume at during test had greater vasoconstriction than another period of the three groups of subject but the heart rate was not significantly altered in the three groups of subjects, can not be used to explain alteration vasodilatation of three group. This may imply that the degree of vasodilatation of the left arm may be controlled by factors other than neural factors such as hormonal factors or other substances such as nitric oxide. (85,31,52,54,63,97)

Fourth condition, pulling pulley with the right hand with 15% MVC condition. In between group, the values of the left arm volume found no significant difference between the three groups of subjects. When related with heart rate at the same time, it can be seen that at during test, anaerobic group had greater increase in the heart rate than aerobic and control groups, anaerobic group had greater increase in the heart rate than aerobic group at minute 6th, aerobic group had greater increase in the heart rate at minute 10th than anaerobic and control group and control group had greater increase in the heart rate at minute 17th than aerobic group. Within the same group, the volume values of the left arm in control group showed that at immediately post-test had greater vasodilatation than during test, minute 10th and 17th, minute 6th had greater vasodilatation than during test and minute 17th. When related with the heart rate at the same time, it can be seen that during test it had greater increase in the heart rate than minute 6th, minute 10th. In aerobic and anaerobic groups the volume values of the left arm had no significant difference in all period. When related with the heart rate at the same time, it can be seen that during test had greater increase in the heart rate than immediately post-test, minute 6th and minute 17th.

Therefore, even there was an increase in sympathetic activity of anaerobic trained subjects at during test period but there was no significant change in the

values of the left arm at the same time. This could be explained that the pulling pulley with the right hand with resistance 15% MVC is indirection stimulation, it also has delay time for responses of the left arm in the three groups of subjects.

Fifth condition, $VO_2\max$ test. In between group, the values of upper extremities and the right leg volume found no significant difference between the three groups of subjects but the volume values of the left leg of aerobic group at pre test had volume greater vasodilatation than control group may imply the adaptation of vascular system in the leg in relation to nature and number of use of the muscle on long duration in competition and training lead to increase blood supply to the muscle (76). When related with heart rate at the same time, it can be seen that control and anaerobic groups had greater increase in the heart rate than aerobic group at immediately post-test and minute 17th, anaerobic group had greater decrease heart rate than the control group at minute 6th. Within the same group, the volume values of the upper and lower extremities in control and anaerobic groups found no significant difference in every period. When compared with the heart rate at the same time, it can be seen that at immediately post-test had greater increase in the heart rate than minute 6th, 10th and 17th, minute 10th had greater increase in the heart rate than minute 17th. In aerobic group, the volume values of the lower extremities and the left arm had no significant difference in every period but in the right arm the volume at minute 17th had greater vasodilatation than immediately period. When related with the heart rate at the same time, similarity between the control and anaerobic groups can be seen.

Therefore, the increase in sympathetic activity of the control and anaerobic groups but no significant change in values of the extremities volume of the three groups of the subjects but in within the same group found that the three groups had similar result that the volume of extremities did not change but there were an increased in sympathetic activity which was highest at immediately post test period and lowest at minute 17th. This may imply that the $VO_2\max$ test condition may be not high enough to stimulate sympathetic activity, it delayed the time for response of the extremities in the three groups of the subjects.

Six condition, is the Wingate test. In between group, the values of the left arm volume in aerobic group had greater vasodilatation at immediately post-test than control group. The volume values of the right arm, of the aerobic group had greater vasodilatation than the control group at the minute 10th and minute 17th. Anaerobic group had greater vasodilatation than control group at minute 10th. The volume values of the left leg, aerobic group had greater vasodilatation than the control group at pre test, immediately post-test and minute 17th. The volume values of the right leg, aerobic group had greater vasodilatation than the control group at pre test, immediately post-test, minute 10th and minute 17th. When related with heart rate at the same time, it can be seen that no difference all groups of subjects, aerobic and anaerobic groups had greater increase in the heart rate than control group at immediately post-test, anaerobic group had greater increase heart rate than aerobic and control groups at minute 6th, minute 10th and minute 17th. Within the same group, control group had the volume values of right arm in minute 17th had greater vasodilatation than minute 10th. The volume values of left leg at minute 10th had greater vasodilatation than immediately post-test and minute 17th. The volume values of the right leg no significant difference all period. When compared with heart rate at the same time, it can be seen that at immediately post-test had greater increase heart rate than minute 6th, 10th and 17th, minute 10th had greater increase in the heart rate than minute 17th. In aerobic group the volume values of left arm in minute 10th had greater vasodilatation than pre test. The volume values of left leg at minute 6th had greater vasoconstriction than immediately post-test, minute 10th and minute 17th. The volume values of right leg at minute 10th had vasodilatation than immediately post-test and minute 6th, minute 17th had vasodilatation than immediately post-test. The volume values of left leg at minute 6th had greater vasoconstriction than immediately post-test, minute 10th and minute 17th. When compared with heart rate at the same time, it can be seen that similarly in control group. In anaerobic group the volume values of right arm in minute 10th had greater vasodilatation than minute 6th. The volume values of left arm and lower extremities no significant difference all period. When compared with heart rate at the same time, it can be seen that similarly in control group.

Therefore, the alteration in the sympathetic activity of both groups of subjects may be used to explain the alteration of vasodilatation compared to sedentary subject. This may imply that the degree of vasodilatation of the extremities may be controlled by other unclear factors other than norepinephrine such as α -receptor agonists on the smooth muscle of vascular systems or other substances such as nitric oxide. (12, 15, 85, 44, 52, 54, 59, 60, 104)

The above findings may imply that the anaerobically trained (short distance runner) have no significant differences of vasoconstriction and vasodilatation in arms and legs between compared to the aerobically trained (long distance runner). This may be due to training in 8 weeks do not make the differences in the relative intensity and energy systems used in the past training of the muscle in the two groups of athletes compared to each other. Many studies report neither low-intensity endurance training nor high intensity sprint training appears to have a significant impact on muscle blood flow when the individual is not engaged in exercise or is not anticipating an ensuing bout of exercise (3, 34). Delp et al (1998) reported that training does not affect muscle blood flow at rest. Most studies with humans indicate that muscle or limb blood flow during exercise at a given submaximal intensity is unchanged (34, 57, 92) by endurance training. One study performed with rats indicates that high-intensity sprint training has no significant effect on muscle perfusion during high intensity, submaximal running (62). The difference in degree of vasodilatation in the leg of aerobically trained subjects compared to sedentary subjects could be explained by the adaptation of vascular system in the leg in relation to nature and number of use of the muscle on long duration in competition and training lead to much blood supply to muscle (76). Two training studies (4, 62) indicate that adaptations in both muscle and nonmuscular tissue perfusion in response to endurance and high-intensity training may be very different during submaximal exercise. In human studies, elevation in blood flow to the trained muscle were observed during heavy exercise (1, 58, 91). Delp et al (1998) reported exercise training may result in elevations in blood flow to specific muscle or muscle parts during anticipation of an dependent bout of exercise, and the specificity is dependent on whether the muscle or muscle part was regularly recruited during the preceding training sessions (16).

The primary vasodilatation mechanism can be caused by metabolic change in nature such as adenosine release from active muscle and endothelium dependent vasodilatation would be secondary to the primary dilatory event and ensuring increase in blood flow. Exercise is associated with increases in plasma catecholamine levels that are intensity related (38). Thus, increased plasma and varicosity level and release of catecholamine would be predicted to induce endothelium derived nitric oxide release. Role of endothelium derived nitric oxide in dilation of skeletal muscle vasculature was extensively demonstrated (69). Other endothelium derived relaxing factors such as vasoactive prostaglandins also seem to be involved in endothelium dependent flow induced dilation of skeletal muscle arterioles (59, 60). Dull and co-worker and Mo and co-worker have suggested that increased flow rate mediates its dilatory effects imply via increase delivery of vasoactive substances to the endothelium (19, 79). Mcallister et al (1995) suggested that experimental results thus far are mixed concerning what role, if any, EDNO plays in mediating the blood flow response to exercise in skeletal muscle. Jungersten and coworkers (1997) found two hours of physical exercise elevated plasma nitrate compared with resting nitrate before exercise. Physical fitness and formation of NO at rest are positively linked to each other. Furthermore, a single session of exercise elicits an acute elevation of NO formation. The observed positive relationships between physical exercise and NO formation may help to explain the beneficial effects of physical exercise on cardiovascular health. Tankersley and co-worker in 1992 studied hypohydration affects forearm vascular conductance were independent of heart rate during exercise. They found that during exercise an attenuated cutaneous vasodilatation is elicited by alterations in regionalized sympathetic outflow, which is unaccompanied by activation of cardiac pacemaker cells (96). These findings may involve increased viscosity may have significance effects during whole body-type exercise. There many studies indicate that reflexes that aid in maintenance of central circulating blood volume were predominate over reflexes that participate in body temperature regulation when both demands are placed on the body. Both blood pressure regulatory and temperature regulatory system share the same effectors (cutaneous vaso&veno motor). During exercise, load are placed on both systems; blood pools in cutaneous veins, cardiac filling pressure decreased, blood pressure

decreased, stimulate cutaneous vasoconstrictor drive which superimpose on vasodilator drive on skin vessels. Further decrease in central blood volume and blood osmolarity will also partially inhibit thermoregulatory drive. During the first two or three weeks of training, the reduction in heart rate parallels the decreases in plasma norepinephrine and epinephrine (76).

The difference of heart rate of aerobic, anaerobic and sedentary subjects may imply the difference in sympathetic responses of aerobic, anaerobic and sedentary subjects which parallel to degree of vasoconstriction and vasodilatation of each groups of subjects or occurred from stress stimulation in immediately period. Therefore, the differences of vasoconstriction of arm and leg of aerobic, anaerobic and sedentary subjects may be partly due to difference in degree of sympathetic responses of arm and leg which had differences in the use and the nature of aerobic and anaerobic training which modify molecular adaptation in the vessels mediated through autonomic nervous system (104). Christman and co-worker 1985 suggested that exercise in the heat increase norepinephrine induced peripheral heat-dissipating capacity and increases catecholamine storage in the preoptic area (12). Bhanot and coworkers (1980) found that the visual and auditory reaction times were shorter in weightlifters than that in gymnast, volleyball and hockey players. This may show that anaerobically trained athletes may have more neuron adaptation in speed than aerobically trained subjects (5). Potts and coworkers (1995) found the slope relating heart rate gain to central venous pressure at rest was significant and increase 114% during exercise, they concluded that a tonic inhibitory interaction between cardiopulmonary baroreceptors and carotid baroreflex control of heart rate during exercise. The aerobic training could induced cardiovascular changes which may include that affect mainly the oxygen transport system. In resting, there are six main changes resulting from training: an increase heart size, a decreased heart rate, an increased stroke volume, no change in resting lung functional parameters, increase blood volume and hemoglobin, and an increased capillary density. In a decreased heart rate that the heart is regulated by two components of the autonomic nervous system: the sympathetic nerve which when stimulated, increase heart rate; and parasympathetic nerve (vagus) which lead to a decrease in the rate when stimulated. With this type of dual neural input, the heart rate can be decreased by increased parasympathetic tone or decreased

sympathetic tone, or a combination of these; however, since it is the parasympathetic nervous system that predominantly regulates heart rate at rest. In an increased capillary density refers to the number of capillaries that surround a skeletal muscle fibers. Long-term endurance training almost always lead to an increased capillary density. This effect indicates that the muscle fibers of highly trained endurance athletes are larger than untrained subjects. Skeletal muscle capillary density related to two factors; the size or diameter of the muscle fiber, and the fiber type or number of mitochondria per muscle fiber (76).

Usefulness of results of experiment can be used for explaining to general resident about effects of exercise that aerobic exercise induce vasodilatation of vessels and adaptation of vascular system lead to decrease blood pressure and decrease risk factor of heart diseases. An anaerobic exercise induce vasoconstriction of vessels and adaptation of neuromuscular system lead to increase performance of movement in some patient in neuromuscular diseases. In all athletes, basic aerobic training can improve performance and normalize of cardiovascular system.

CHAPTER 6

CONCLUSION

1. In inflated blood pressure cuff at the left upper arm condition, there seem to be no significant change in the sympathetic activity and values of the left arm volume observed in the three groups of subject.

2. In inflated blood pressure cuff at the left upper arm condition, it seem to have increase in sympathetic activity of anaerobic trained but the values of the left arm volume at the same time had greater vasodilatation than control group.

3. In pulling the pulley with the left hand with 15% MVC condition, there was increase in sympathetic activity of aerobic and anaerobic trained subjects but there was no significant change in the values of the left arm volume at the same time.

4. In pulling the pulley with the right hand with 15% MVC condition, there was increase in sympathetic activity of anaerobic trained subjects at during test period but there was no significant change in the values of the left arm volume at the same time.

5. In VO_{2max} test condition, there was increase in sympathetic activity of control and anaerobic trained subjects but there was no significant change in the values of the upper and lower extremities volume of the three groups of the subjects.

6. In Wingate test condition, aerobically trained subjects will have greater degree of vasodilatation in the left and right legs than sedentary subjects at immediately period, at minute 6th and 17th.

7. Greater degree of vasodilatation in the left leg and right leg of aerobically trained could be explained by the adaptation of vascular system, vasodilatation mechanism would be metabolic in nature such as adenosine release from active muscle and endothelium dependent vasodilatation.

8. The different of heart rate of aerobic, anaerobic and sedentary subjects imply the difference in sympathetic responses which may parallel to the degree of vasodilatation in leg of aerobic trained subjects.

REFERENCE

1. Anderson, P., and B. Saltin. Maximal perfusion of skeletal muscle in man. *J. Appl. Physiol.* 166:233-249, 1985.
2. Armstrong, R. B., D. A. Hayes, and M. D. Delp. Blood flow distribution in rat muscles during preexercise anticipatory re-sponse. *J. Appl. Physiol.* 67:1855-1861, 1989.
3. Armstrong, R. B. Influence of exercise training on O₂ delivery to skeletal muscles. In *The lung: Scientific Foundations*. R. G. Crystal, J. B. West, E. R. Weibel and P. J. Barnes (ED.). New York: Raven Press, Ltd., 1991, pp. 1517-1524.
4. Armstrong, R. B., and M. H. Laughlin. Exercise blood flow patterns within and among rat muscles after training. *Am. J. Appl. Physiol.* 246 (*Heart Circ. Physiol.* 15):H59-H69, 1984.
5. Bhanot, J. L., and L. S. Sidhu. Comparative study of reaction time in Indian sportsmen specializing in hockey, volleyball, weightlifting and gymnastics. *J. Sports Med. Phys. Fitness.* 1980; 20:113-118.
6. Briele, H. A., S. Schneebaum, M. Barnicle, and C. S. Briele. Method of measurement for volume of an extremity. *Surgery, Gynecology & Obstetrics.* 1989; 169:349-351.
7. Calbet, J. A. L., J. A. De Paz, N. Garatachea, S. Cabeza de Vaca, and J. Chauarren. Anaerobic energy provision does not limit wingate exercise performance in endurance trained cyclist. *J. Appl. Physiol.* 94:668-676, 2003.
8. Carten Stick, Hanno Jaeger, and Erich Witzleb. Measurements of volume changes and venous pressure in the human lower leg during walking and running. *J. Appl. Physiol.* 72(6):2063-2068, 1992.
9. Chao Han, W., and Wayne Lantt. Blockade of nitric oxide synthase potentiates the suppression of vasodilators by norepinephrine in the hepatic artery. *Nitric Oxide.* (3):172-179, 1999.

10. Chauying, J. Jen., Hung-pin Chan, and Hsium-ing Chen. Chronic exercise improves endothelial calcium signal and vasodilation in hypercholesterolemic rabbit femoral artery. *5th FAOPS Congress Kuala Lumpur: 23-26 Sept, 2002.*
11. Cheah, L. H., A. Parkin, P. Gilson, et al. Limb volume measurements in peripheral arterial disease. *Clinical Physics & Physiological Measurement.* 1989; 10:75-79.
12. Christman, V. John, and V. Carl Gisolfi. Heat acclimation: role of norepinephrine in the anterior hypothalamus. *J. Appl. Physiol.* 58(6):1923-1928, 1985.
13. Cornish, B. H., I. H. Bunce, L. C. Ward, et al. Bioelectrical impedance for monitoring the efficacy of lymphoedema treatment programs. *Breast Cancer Res Treat.* 1996; 38:169-176.
14. Danieals, J., and N. Scardinia. Interval training and performance. *Sports Medicine,* 1:327, 1984.
15. Dean L. Kellogg, Jr., M. John, Johnson, and W.A. Kosiba. Control of internal temperature threshold for active cutaneous vasodilation by dynamic exercise. *J. Appl. Physiol.* 71(6): 2476-2482, 1991.
16. Delp, N. D. Differential effects of training on the control of skeletal muscle perfusion. *Med. Sci. Sports Exerc., Vol.30 No. 3,* pp. 361-374, 1998.
17. Dinerman, J. L., C. J. lowenstein, and S. H. Snyder. Molecular mechanisms of nitric oxide regulation. Potential relevance to cardiovascular disease. *Circ Res.*73:217-222, 1993.
18. Don D. Sheriff. Muscle pump function during locomotion:mechanical coupling of stride frequency and muscle blood flow. *Am. J. Physiol. (Heart Circ. Physiol).* 284:H2185-H2191, 2003.
19. Dull, R. O., and P. F. Davies. Flow modulation of agonist (ATP) response (Ca²⁺) coupling in vascular endothelial cells. *Am .J. Physiol. 261 (Heart.Circ.Physiol.30) :H149-H154,* 1991.
20. Edward Fox, Richard Bowers, and Merle Foss. The physiological basic for exercise and sport; 5th edition; 31, 1993.
21. Edward Fox, Richard Bowers, Merle Foss; The physiological basic for exercise and sport; 5th edition; 16-25, 1993

22. Edward L. Fox, Richard W. Bowers, Merle L. Foss. The Physiological basis for exercise and sports, 5th edition; Brown & Benchmark; 30-38, 1993.
23. Erika Bama, Kurt Bruck, and Heinz Peter Schwennicke. Adaptive modifications in the thermoregulatory system of long distance runners. *J. Appl. Physiol.* 40(3):404-410, 1976.
24. Exercise Physiology Laboratory Techniques. Department of Physiology, Faculty of Science, Mahidol University, 2003.
25. Falk, B., O. Bar-or, J. Smolander, and G. Frost. Response to rest and exercise in the cold: effects of age and aerobic fitness. *J. Appl. Physiol.* 76(1):72-78, 1994.
26. Febbraio, M.A., M.F. Carey, R.J. Snow, C.G. Stathis, and M. Hargreaves. Influence of elevated muscle temperature on metabolism during intense, dynamic exercise. *Am. J. Physiol.* 271 (Regulatory Integrative Comp. Physiol. 40):R1251-R1255, 1996.
27. Fortney, S. M., C. B. Wenger, J. R. Bove, and E. R. Nadel. Effect of blood volume on forearm venous and cardiac stroke volume during exercise. *J. Appl. Physiol. : Respirat Environ. Exercise Physiol.* 55(3): 884-890, 1983.
28. Fouriner, M., et al. Skeletal muscle adaptation in adolescent boys: sprint and endurance training and detraining. *Med. Sci. Sport Exerc.*, 14:453, 1982.
29. Fox, E. L., et al. Frequency and duration of interval training program and changes in aerobic power. *J. Appl. Physiol.*, 38:481, 1975.
30. Furchgott, R. F., and J. V. Zawadzki. The obligatory role of endothelial cells in the relaxation of arterial smooth muscle by acetylcholine. *Nature.* 288:373-376, 1980.
31. Gisolfi, Carl V., and V. John Christman. Thermal effects of injecting norepinephrine into hypothalamus of the rat during rest and exercise. *J. Appl. Physiol.: Respirat. Environ. Exercise Physiol.* 49(6): 937-941, 1980.
32. Green, H. J., J. A. Thomson, M. E. Bali, R. L. Hughson, H. E. Houston, and M. T. Sharratt. Alterations in blood volume following short term supramaximal exercise. *J. Appl. Physiol. : Respirat. Environ. Exercise Physiol.* 56(1): 145-149, 1984.

33. Grimby, G. Renal clearance during prolonged supine exercise at different loads, *J. appl. Physiol.* 20:1294-1298, 1965.
34. Grimby, G., E. Haggendal, and B. Saltin. Local xenon 133 clearance from the quadriceps muscle during exercise in man. *J. Appl. Physiol.* 22:305-310, 1967.
35. Hakinen, K. Neuromuscular and hormonal adaptation in athletes to strength training in two years. *J. Appl. Physiol.* 1988; 65: 2406-2409.
36. Halliwill, John R., Christopher T. Minson, and Michael J. Joyner. Measurement of limb venous compliance in humans: technical considerations and physiological finding. *J. Appl. Physiol.* 87(4): 1555-1563, 1999.
37. Harrison, M. H., R. J. Edwards, and P. A. Fennessy. Intravascular volume and tonicity as factors in the regulation of body temperature. *J. Appl. Physiol.: Respirat. Environ. Exercise Physiol.* 44(1):69-75, 1978.
38. Hartley, L. H., J. W. Mason, R. P. Hogan, et al. Multiple hormonal responses to graded exercise in relation to physical training. *J. Appl. Physiol.* 33:602-606, 1972.
39. Heyward, V.H. Advanced Fitness Assessment and Exercise Prescription. 2nd ed. Champaign; IL. Human Kinetics. 1991 Ch. 2.
40. Holloszy, J. O. Metabolic consequences of endurance exercise training. In *Exercise, Nutrition, and energy metabolism*. Edited by E. S. Horton, and R. L. Terjung. New York, Macmillan, 1988.
41. Houston, M. E., and J. A. Thompson. The response of endurance adapted adults to intense anaerobic training. *Eur. J. Appl. Physiol.* 36:207, 1977.
42. Jean Cleroux, N. Guessan Kouame, Andre Nadeau, Denis Coulombe, and Y. Ves Lacourciere. baroreflex regulation of forearm vascular resistance after exercise in hypertensive and normotensive humans. *Am. J. Physiol.* 263 (*Heart Circ.:Physiol.* 32): H1523-H1531, 1992.
43. John M. Johnson and Loring B. Rowell. Forearm skin and muscle vascular responses to prolonged leg exercise in man. *J. Appl. Physiol.* 39(6): 920-924, 1975.
44. John M. Johnson and Myung K. Park. Effect of heat stress on cutaneous vascular response to the initiation of exercise. *J. Appl. Physiol. :Respirat. Environ.*

Exercise Physiol. 53(3):744-749, 1982.

45. John M. Johnson, George L. Brengelmann, and Loring B. Rowell. Interactions between local and reflex influences on human forearm skin blood flow. *J. Appl. Physiol.* 41(6): 826-831, 1976.
46. John V. Christman, and Carl V. Gisolfi. Heat acclimation: role of norepinephrine in the anterior hypothalamus. *J. Appl. Physiol.* 58(6): 1923-1928, 1985.
47. John, B., H. Jane, and M. Gareth. Exercise on prescription: Cardiovascular activity for health. Butterworth-Heinemann, 1999.
48. John, P. C., P. D. Wagner, and D. F. Wilson. Regulation of oxidative metabolism and blood flow in skeletal muscle. *Med. Sci. Sport Exerc.* 28(3):305-314, 1996.
49. Johnson, J. M., D. S. O'Leary, W. E. Taylor and W. Kosiba. Effect of local warming on forearm reactive hyperemia. *Clin Physiol.* 6:337-346, 1986.
50. Jungersten Lennart, Anneli Ambring, Bjorn Wall and Ake Wennmalm. Both physical fitness and acute exercise regulate nitric oxide formation in healthy humans. *J. Appl. Physiol.* 82 : 760 - 764, 1997.
51. Kanehisa, H., and T. Fukunaga. Profiles of musculoskeletal development in limbs of college Olympic weightlifters and wrestlers. *Eur J Appl Physiol* 1999; 79:414-420.
52. Kellogg, D. L., Jr., C. G. Crandall, Y. Liu, N. Charkoudian, and J. M. Johnson. Nitric oxide and cutaneous active vasodilation during heat stress in humans. *J. Appl. Physiol.* 85(3): 824-829, 1998.
53. Kellogg, D. L., Jr., J. L. Zhao, C. Friel, and L. J. Roman. Nitric oxide concentration increases in the cutaneous interstitial space during heat stress in humans. *J. Appl. Physiol.* 94:1971-1977, 2003.
54. Kellogg, D. L., Jr., Y. Liu, I. F. Kosiba, and D. O. Donnell. Role of nitric oxide in the vascular effects of local warming of the skin in humans. *J. Appl. Physiol.* 86(4):1185-1190, 1999.
55. Khamwong, P. The analysis of correlation among physical characteristics, sport ability and balance. M. Sc. thesis (Exercise Physiology), Mahidol University, 1993.

56. King, T. The effect of water temperature on hand volume during volumetric measurement using the water displacement method. *Journal of Hand Therapy*. July-September 1993; 202-204.
57. Klassen, G. A., G. M. Andrew, and M. R. Becklake. Effect of training on total and regional blood flow and metabolism in paddlers. *J. Appl. Physiol.* 28:397-406, 1970.
58. Klausen, K., N. Secher, J. P. Clausen, O. Hartling, and J. Trap-Jensen. Central and regional circulatory adaptations to one-leg training. *J. Appl. Physiol.:Respir. Environ. Exerc. Physiol.* 52:976-983, 1982.
59. Klitzman, B., and B. R. Duling. Microvascular hematocrit and red cell flow in resting and contracting striated muscle. *Am. J. Physiol.* 237 (Heart Circ.Physiol.6):H481-H490, 1979.
60. Koller, A., D. Sun, A. Huang, and G. Kaley. Colerease of nitric oxide and prostaglandins mediates flow-dependent dilation of rat gracilis muscle arterioles. *Am. J. Physiol.* 267 (Heart Circ. Physiol. 36):H326-H332, 1994.
61. Kraemer, W. J., J. Patton, S. E. Gordon, et al. Compatibility of high intensity strength and endurance training on hormonal and skeletal muscle adaptations. *J. Appl. Physiol.* 1995; 78:976-989.
62. Laughoin, M. H., R. J. Korthuis, W. L. Sexton, and R. B. Armstrong. Regional muscle blood flow capacity and exercise hyperemia in high-intensity trained rats. *J. Appl. Physiol.* 64:2420-2427, 1988.
63. Lennart Jungersten, Anneli Ambring, Bjorn Wall, and Ake Wennmalm. Both physical fitness and acute exercise regulate nitric oxide formation in healthy humans. *J. Appl. Physiol.* 82:760-764, 1997.
64. Martin, W. H., W. M. Kohet, M. T. Malley, E. Korte, and S. Stoltz. Exercise training enhances leg vasodilatory capacity of 65-yr-old men and women. *J. Appl. Physiol.* 69:1804-1809, 1990.
65. Mcallister, R. M. Endothelial-mediated control of coronary and skeletal muscle blood flow during exercise :introduction. *Med. Sci. Sport Exerc.* 27(8):1122-1124, 1995.
66. McAllister, R. M., M. D. Delp, and M. H. Laughlin. Endothelium-derived nitric oxide and control of blood flow during exercise. In: *Pharmacology in*

Exercise and Sports. S. M. Somani (Ed.) Boca Raton, FL.: CRC Press, 1996, pp. 191-209.

67. Mcallister, R. M., T. Hirai, and T. I. Musch. Contribution of endothelium-derived nitric oxide (EDNO) to the skeletal muscle blood flow response to exercise. *Med. Sci. Sport Exerc.* 27(8):1145-1151
68. McAllister, R. M., Tadakazu Hirai, and T. I. Musch. Contribution of endothelium derived nitric oxide (EDNO) to the skeletal muscle blood flow response to exercise. *Med. Sci. Sport. Exerc.*, Vol. 27, No. 8, pp. 1145-1151, 1995.
69. Mcallister, R.M. , T. Hirai, and T.I. Musch. Contribution of endothelium-derived nitric oxide(EDNO) to the skeletal muscle blood flow response to exercise. *Med. Sci. Sport Exerc.*, Vol. 27, No. 8, pp. 1145-1157, 1995.
70. McArdle, W. D., and F. I. Katch. Sports and exercise nutrition, Lippincott Williams & Wikins Company, USA, 1999.
71. McArdle, W. D., F.I. Katch, and V. L. Katch. Exercise physiology energy nutrition and human performance: 3rd edition; 441-444, 1991.
72. McArdle, W. D., F.I. Katch, and V. L. Katch. Exercise physiology energy nutrition and human performance: 3rd edition; 429-433, 1991.
73. McArdle, W. D., F.I. Katch, and V. L. Katch. Exercise physiology energy nutrition and human performance: 3rd edition; 428-429, 1991.
74. McDougall, J. D., et al. Biochemical adaptation of human skeletal muscle to heavy resistance training and mobilization. *J. Appl. Physiol.* 43:700, 1977.
75. McMurray, R. G., and S. M. Horvath. Thermoregulation in swimmers and runners. *J. Appl. Physiol.: Respirat. Environ. Exercise Physiol.* 46(6):1086-1092, 1979.
76. Merle, L. Foss., and Steven, J. Keteyian.Fox's. Physiological basis for exercise and sport.6th edition, 243-245.
77. Michael C. Hogan, Bruno Grassi, Michele Samaja, Creed M.Stary, and L. B. Gladden. Effect of contraction frequency on the contractile phases of muscle venous blood flow. *J. Appl. Physiol.* 95:1139-1144, 2003.
78. Michael, B. Ducharme, and Peter Tikuisis. Role of blood as heat source or sink in human limbs during local cooling and heating. *J. Appl. Physiol.* 76(5): 2084-2094, 1994.

79. Mo, M., S. G. Eskin, and W. P. Schilling. Flow-induced changes in Ca^{2+} signaling of vascular endothelial cell: Effect of shear stress and ATP. *Am. J. Physiol.* 260(Heart. Circ. Physiol. 29):H1698-H1707, 1991.
80. Moncada, S. R., M. J. Palmer, and E. A. Higgs. The discovery of nitric oxide as the endogenous nitrovasodilator. *Hypertention* 12:365-372, 1988.
81. Morganroth, J., et al. Comparative left ventricular dimensions in trained athletes. *Ann. Intern. Med.*, 82:521, 1975.
82. Nielsen, B., G. Savard, E.A. Richter, M. Hargreaves, and B. Saltin. Muscle blood flow and muscle metabolism during exercise and heat stress. *J. Appl. Physiol.* 69(3):1040-1046, 1990.
83. Pergola, P. E., D. L. Kellogg, Jr., J. M. Johnson and W. A. Kosiba. Role of sympathetic nerves in the vascular effects of local temperature in human forearm skin. *Am J. Appl. Physiol.* 256 (Heart Circ. Physiol. 34) : H785-H792, 1993.
84. Potts, Jeffrey T., Xiangrong Shi and Peter B. Raven. Cardiopulmonary baroreceptors modulate carotid baroreflex control of heart rate during dynamic exercise in humans. *Am. J. Appl. Physiol.* 268 (Heart Circ. Physiol. 37) : H1567-H1576, 1995.
85. Radegran, G., and B. Saltin. Nitric oxide in the regulation of vasomotor tone in human skeletal muscle. *Am. J. Physiol. (Heart Circ. Physiol.* 276) :H1951-H1969, 1999.
86. Robert Carter III, Thad E. Wilson, Donald E. Watenpaugh, Michael L. Smith, and Craig G. Crandall. Effects of mode of exercise recovery on thermoregulatory and cardiovascular responses. *J. Appl. Physiol.* 93:1918-1924, 2002.
87. Romeshan Sunthareswaran. Cardiovascular system, 1998, pp. 63-77
88. Rowell, L., J. Blackmon, and R. Bruce. Indo cyanine green clearance and estimated hepatic blood flow during mild to maximal exercise in upright man. *J. Clin. Invest.* 43; 1677-1690, 1964.
89. Rowell, L., J. Blackmon, and R. Bruce. Indo cyanine green clearance and estimated hepatic blood flow during mild to maximal exercise in upright man. *J. Clin. Invest.* 43; 1677-1690, 1964.

90. Rowell, L., J. Blackmon, R. Martin, J. Mazzarella, and R. Bruce. Hepatic clearance of indocyanine green in man under thermal and exercise stresses. *J Appl Physiol.* 20:384-394, 1965
91. Saltin, B., B. Kiens, G. Savard, and P. K. Pederson. Role of hemoglobin and capillarization for oxygen delivery and extraction in muscular exercise. *Am. J. Physiol.* 128:21-32, 1986.
92. Saltin, B., K. Nazar, D. L. Costill, et al. The nature of the training response: Peripheral and central adaptations to one-legged exercise. *Acta physiol. Scand.* 96:289-305, 1976.
93. Staron, R. S., D. L. Karapondo, W. J. Kraemer, et al. Skeletal muscle adaptations during early phase of heavy-resistance training in men and women. *J. Appl. Physiol.* 1994; 76:1247-55.
94. Takeishi Nishiyasu, Xiangrong Shi, Gary W. Mack, and Ethan R. Nadel. Effect of hypovolemia on forearm vascular resistance control during exercise in the heat. *J. Appl. Physiol.* 71(4):1382-1386, 1991.
95. Tankersley, C. G., D. H. Zappe, T. G. Meister, and W. L. Kenney. Hypohydration affects forearm vascular conductance independent of heart rate during exercise. *J. Appl. Physiol.* 73(4):1232-1237, 1992.
96. Tankersley, C. G., J. Smolander, W. L. Kenney, and S. M. Fortney. Sweating and skin blood flow during exercise: effects of age and maximal oxygen uptake. *J. Appl. Physiol.* 71(1):236-242, 1991.
97. Terence P. Connelly, Lois M. Sheldahl, Felix E. Tristani, Scot G. Levandoski, Ronald K. Kalkhoff, Martin D. Hoffman, and John H. Kalbfleisch. Effect of increased central blood volume with water immersion on plasma catecholamines during exercise. *J. Appl. Physiol.* 69(2):651-656, 1990.
98. Therminrias, A., P. Flore, M. F. Oddou-chirpaz, C. Gharib, and G. Gauquelin. Hormonal responses to exercise during moderate cold exposure in young VS. middle-aged subjects. *J. Appl. Physiol.* 73(4):1564-1571, 1992.
99. Timothy I. Musch, Kevin E. Eklund, K. Sue Hageman, and David C. Poole. Altered regional blood flow response to submaximal exercise in older rats. *J. Appl. Physiol.* 5, 2003.

100. Tschakovsky, M. E., J. K. Shoemaker and R. L. Hughson. Vasodilatation and muscle pump contribution to immediate exercise hyperemia. *Am J. Appl. Physiol. (Heart Circ Physiol.271)*:H1697-H1701, 1996.
101. Vogel, R.B. Increase of free and total testosterone during submaximal exercise in normal males. *Med. Sci. Sports Exerc.* 1985; 17:119-122.
102. William C. Adams. Foundations of physical education, exercise, and sport science, 1991, pp. 80-81
103. William E. Garrett, Jr., M D, PhD, and Donald T. Kirkendall, PhD, editor. Exercise and sport science: Cardiovascular response to exercise and training (Barry A. Franklin). Philadelphia: Lippincott Williams and Wilkins company; 107-116, 2000.
104. ภาควิชาสรีรวิทยา คณะวิทยาศาสตร์ มหาวิทยาลัยมหิดล, หน้า 67-68

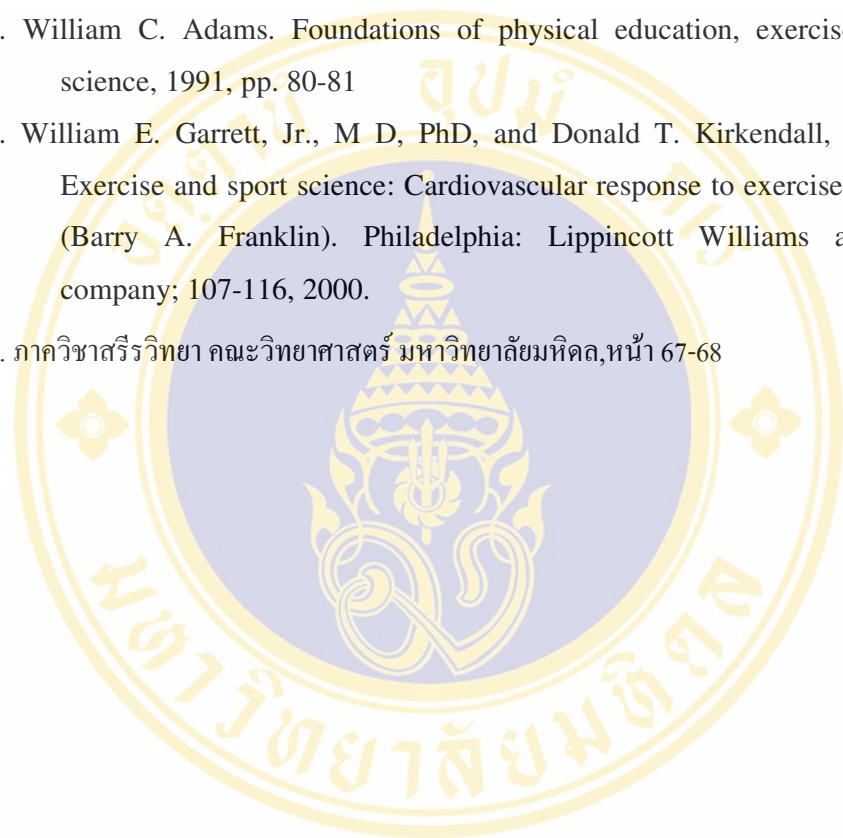



APPENDIX A



Figure 20 Digital weight machine (AD-6201, Japan).

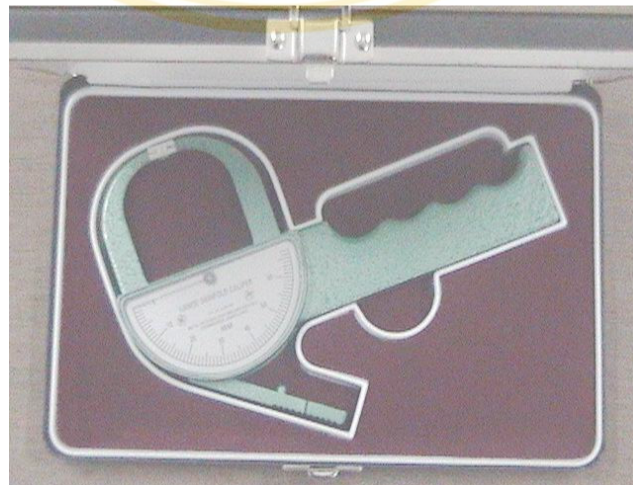

Figure 21 Skinfold Caliper (F-LSC, England)

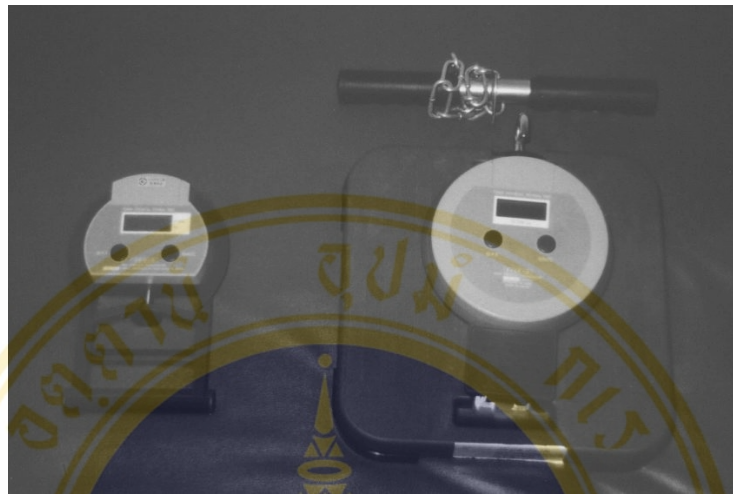

Figure 22 Hand Grip and Back-Leg Dynamometer (Takei & Company, Japan).



Figure 23 Wingate test machine set

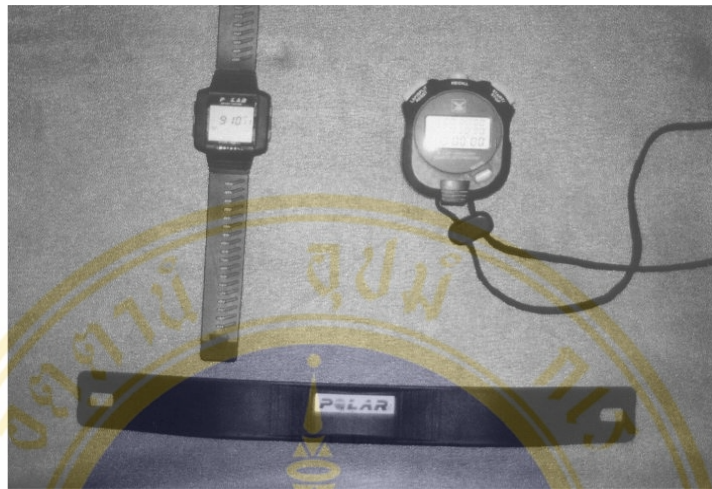

Figure 24 Polar (F-PLC, Finland)



Figure 25 Sit and reach box (Sports Science Program, Rajabhat Loei University)



Figure 26 Volumeter (Biomedical Equipment technology, Mahidol University) side view



Figure 27 Volumeter (Biomedical Equipment technology, Mahidol University) front view

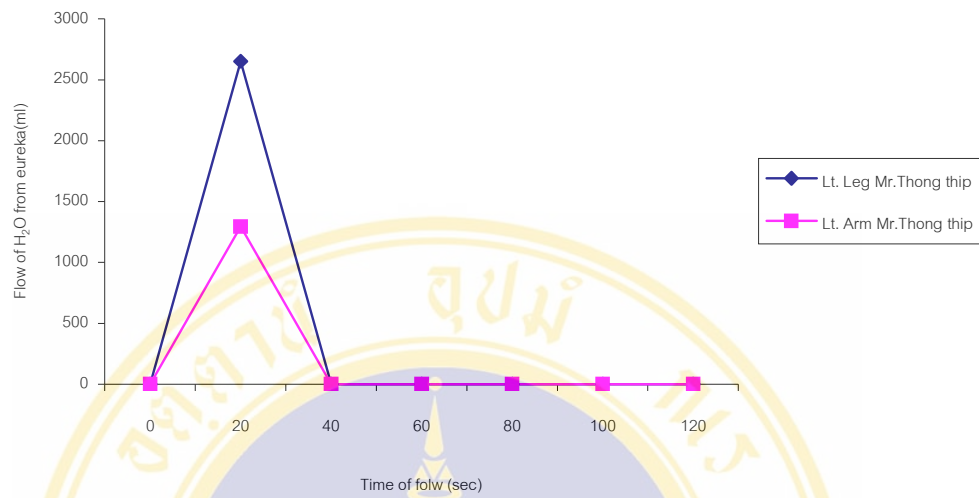

Figure 19A Technical data of flow rate / 20 sec., period = 120 sec., normal collection, H₂O 1000 = 992 g.

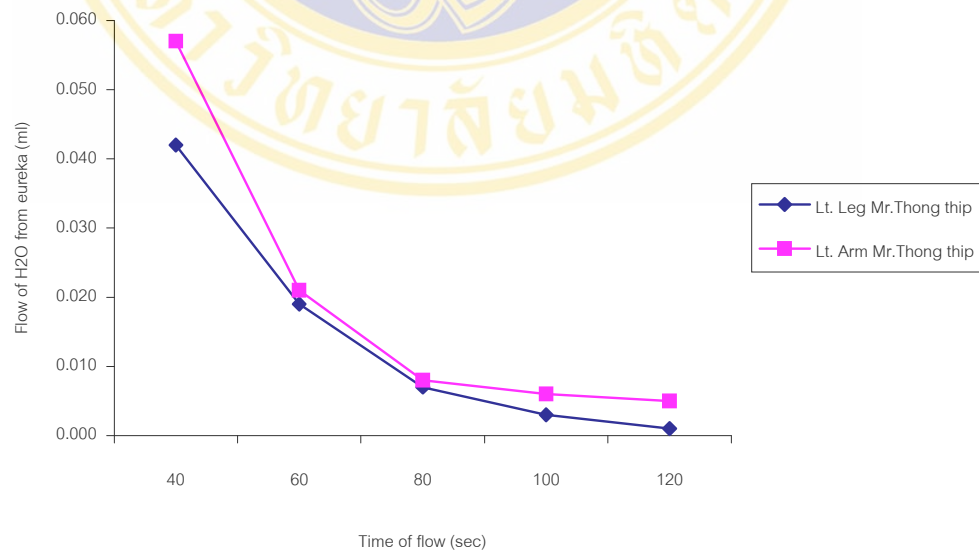

Figure 19B Technical data of flow rate / 20 sec., period at 40 to 120 sec., normal collection, H₂O 1000 = 992 g.

APPENDIX B

Table 3 Arm volume (Liter) of individual subject in control group

	Left arm volume control group (Liter)											
	Left Inflated Blood Pressure Cuff						Right Inflated Blood Pressure Cuff					
	Pre	T1	T2	T3	T4	Pre	T1	T2	T3	T4		
Control 1	1.149	1.314	1.282	1.272	1.231	1.299	1.242	1.200	1.168	1.141		
Control 2	.729	.818	.789	.752	.739	.729	.702	.715	.721	.719		
Control 3	1.123	1.106	1.119	1.125	1.115	1.184	1.233	1.250	1.229	1.202		
Control 4	1.250	1.266	1.280	1.275	1.268	1.218	1.189	1.223	1.169	1.150		
Control 5	.668	.773	.772	.727	.694	.670	.696	.703	.681	.674		
Control 6	.861	.707	.729	.750	.789	.782	.807	.818	.801	.780		
Control 7	.871	.895	.868	.855	.865	.875	1.006	.963	.932	.910		
Control 8	1.407	1.316	1.329	1.350	1.385	1.207	1.294	1.269	1.255	1.261		
Control 9	1.459	1.347	1.373	1.391	1.417	1.001	1.369	1.318	1.293	1.239		
Control 10	1.119	1.136	1.150	1.137	1.121	1.185	1.237	1.227	1.182	1.190		
Control 11	1.118	1.048	1.064	1.083	1.113	1.023	.958	.968	.995	.982		
Control 12	.930	.962	.973	.967	.946	.933	.959	.975	.951	.948		

Table 4 Arm volume (Liter) of individual subject in control group

	Left arm volume control group (Liter)														
	Left Pull Pulley							Right Pull Pulley							
	Pre	T1	T2	T3	T4	Pre	T1	T2	T3	T4	Pre	T1	T2	T3	T4
Control 1	1.315	1.291	1.280	1.261	1.285	1.209	1.330	1.290	1.260	1.217	1.209	1.330	1.290	1.260	1.217
Control 2	.870	.865	.851	.828	.867	.807	.827	.812	.781	.770	.807	.827	.812	.781	.770
Control 3	1.108	1.195	1.158	1.135	1.105	1.193	1.292	1.263	1.239	1.190	1.193	1.292	1.263	1.239	1.190
Control 4	1.246	1.292	1.272	1.252	1.244	1.275	1.238	1.288	1.267	1.250	1.275	1.238	1.288	1.267	1.250
Control 5	.739	.727	.712	.701	.736	.723	.766	.752	.735	.713	.723	.766	.752	.735	.713
Control 6	.908	.919	.892	.924	.905	.909	.922	.914	.901	.896	.909	.922	.914	.901	.896
Control 7	.601	.800	.781	.748	.712	.652	.701	.688	.671	.551	.652	.701	.688	.671	.551
Control 8	1.384	1.282	1.300	1.371	1.382	1.414	1.391	1.408	1.381	1.419	1.414	1.391	1.408	1.381	1.419
Control 9	1.333	1.267	1.284	1.303	1.317	1.372	1.329	1.308	1.332	1.363	1.372	1.329	1.308	1.332	1.363
Control 10	1.278	1.138	1.183	1.207	1.248	1.153	1.297	1.265	1.238	1.207	1.153	1.297	1.265	1.238	1.207
Control 11	.890	.997	.973	.940	.895	.950	1.005	.984	.970	.948	.950	1.005	.984	.970	.948
Control 12	.790	.783	.774	.786	.791	.786	.815	.791	.769	.756	.786	.815	.791	.769	.756

Table 5 Arm volume (Liter) of individual subject in control group

	Left Arm volume control group (Liter)											
	VO max test						Wingate test					
	Pre	T1	T2	T3	T4	Pre	T1	T2	T3	T4		
Control 1	1.235	1.276	1.255	1.220	1.273	1.274	1.302	1.298	1.195	1.202		
Control 2	1.126	.812	1.128	.741	.726	.578	.600	.646	.678	.690		
Control 3	1.141	1.103	1.065	1.033	1.026	1.002	1.126	1.096	1.118	1.133		
Control 4	1.076	1.155	1.138	1.196	1.133	1.105	1.218	1.131	1.191	1.177		
Control 5	.894	.735	.654	.615	.661	.662	.616	.859	.848	.953		
Control 6	1.176	.864	1.207	1.130	1.112	.819	.908	.771	.642	.736		
Control 7	.840	.913	.776	.949	.879	.816	.706	.784	.708	.787		
Control 8	1.328	1.398	1.383	1.239	1.235	1.346	1.268	1.236	1.309	1.313		
Control 9	1.285	1.296	1.234	1.343	1.215	1.320	1.304	1.256	1.247	1.260		
Control 10	1.181	1.185	1.195	1.244	1.234	1.203	1.141	1.200	1.226	1.162		
Control 11	.976	1.101	1.011	.955	.996	1.049	.949	.953	.996	1.005		
Control 12	.891	.732	.651	.612	.658	.658	.613	.856	.845	.950		

Table 6 Arm volume (Liter) of individual subject in control group

	Right Arm volume control group (Liter)											
	VO max test						Wingate test					
	Pre	T1	T2	T3	T4	Pre	T1	T2	T3	T4		
Control 1	1.082	1.347	1.255	1.354	1.293	1.384	1.280	1.307	1.232	1.182		
Control 2	1.247	.955	1.103	.699	.700	.600	.662	.722	.697	.759		
Control 3	1.151	1.130	1.214	1.196	1.102	1.142	1.128	1.124	.997	1.149		
Control 4	1.185	1.354	1.303	1.279	1.247	1.238	1.288	1.429	1.228	1.338		
Control 5	1.026	.879	.659	.609	.688	.667	.646	.590	.689	.809		
Control 6	1.303	.862	1.249	1.076	1.099	.834	.985	.981	.688	.828		
Control 7	.742	.708	.919	.987	.945	.940	.958	.780	.896	1.028		
Control 8	1.194	1.290	1.328	1.256	1.246	1.306	1.260	1.418	1.300	1.448		
Control 9	1.205	1.264	1.146	1.162	1.210	1.224	1.255	1.310	1.283	1.164		
Control 10	1.230	1.138	1.292	1.240	1.135	1.190	1.225	1.214	1.262	1.240		
Control 11	1.074	.951	1.010	1.010	1.123	1.001	.999	.997	1.028	1.070		
Control 12	1.023	.876	.656	.606	.685	.664	.643	.586	.685	.805		

Table 7 Leg volume (Liter) of individual subject in control group

	Left Leg volume control group (Liter)											
	VO max test						Wingate test					
	Pre	T1	T2	T3	T4	Pre	T1	T2	T3	T4		
Control 1	2.579	2.461	2.545	2.498	2.685	2.518	2.373	2.452	2.651	2.649		
Control 2	2.194	2.229	2.145	2.131	1.778	1.815	2.005	2.003	1.893	1.915		
Control 3	2.574	2.527	2.544	2.502	2.590	2.424	2.423	2.845	2.677	2.659		
Control 4	2.628	2.610	2.706	2.701	2.817	2.797	2.735	2.805	2.846	2.837		
Control 5	1.688	1.757	1.654	1.682	1.628	1.735	1.677	1.706	2.145	1.666		
Control 6	2.422	2.421	2.322	2.397	2.371	2.358	2.272	1.769	2.345	2.285		
Control 7	2.788	2.747	2.888	2.771	2.794	2.825	2.896	3.003	2.654	2.925		
Control 8	2.629	2.824	2.730	2.753	2.772	2.977	2.898	2.830	3.004	3.077		
Control 9	3.513	3.113	3.252	3.293	3.134	3.294	3.134	3.240	3.396	3.356		
Control 10	2.889	2.836	2.860	2.927	2.910	2.900	2.896	2.768	2.818	2.800		
Control 11	2.252	2.305	2.354	2.305	2.253	2.354	2.180	2.227	2.403	1.529		
Control 12	1.685	1.752	1.651	1.680	1.625	1.731	1.674	1.702	2.143	1.663		

Table 8 Leg volume (Liter) of individual subject in control group

	Right Leg volume control group (Liter)											
	VO max test						Wingate test					
	Pre	T1	T2	T3	T4	Pre	T1	T2	T3	T4		
Control 1	2.482	2.553	2.668	2.645	2.703	2.499	2.589	2.655	2.639	2.684		
Control 2	2.023	2.344	2.336	2.082	1.729	1.794	1.787	1.825	1.864	1.758		
Control 3	2.620	2.715	2.849	2.597	2.492	2.739	2.565	2.893	2.594	2.570		
Control 4	2.730	2.940	3.009	2.991	2.904	2.803	2.789	2.841	2.952	3.082		
Control 5	1.635	1.666	1.644	1.672	1.690	1.779	1.577	1.577	1.776	1.658		
Control 6	2.191	2.418	2.111	2.258	2.294	1.906	2.197	2.180	2.080	2.352		
Control 7	2.578	2.573	2.685	2.648	2.659	2.753	2.657	2.779	2.628	2.826		
Control 8	2.765	2.860	2.780	2.966	3.034	3.135	3.113	3.004	3.083	3.410		
Control 9	3.160	3.286	3.162	3.304	3.137	3.171	3.166	3.332	3.327	3.150		
Control 10	2.786	2.939	2.800	2.936	2.760	2.880	2.877	2.733	2.777	2.820		
Control 11	2.264	2.206	2.488	2.367	2.421	2.406	2.320	2.543	2.493	1.997		
Control 12	1.632	1.663	1.641	1.669	1.687	1.786	1.574	1.574	1.173	1.655		

Table 9 Arm volume (Liter) of individual subject in aerobic group

	Left arm volume aerobic group (Liter)														
	Left Inflated Blood Pressure Cuff							Right Inflated Blood Pressure Cuff							
	Pre	T1	T2	T3	T4	Pre	T1	T2	T3	T4	Pre	T1	T2	T3	T4
Aerobic 1	.999	.954	.981	1.019	.988	.892	.631	.718	.755	.822					
Aerobic 2	1.520	1.437	1.403	1.411	1.445	1.382	1.466	1.450	1.441	1.422					
Aerobic 3	1.175	1.005	1.078	1.112	1.255	1.088	.951	1.023	1.072	1.054					
Aerobic 4	1.076	1.140	1.124	1.112	1.083	1.188	1.173	1.208	1.191	1.213					
Aerobic 5	1.120	1.060	1.100	1.102	1.052	1.147	1.104	1.133	1.076	1.092					
Aerobic 6	1.258	1.158	1.150	1.193	1.172	1.261	1.117	1.129	1.161	1.202					
Aerobic 7	1.254	1.331	1.348	1.323	1.300	1.369	1.237	1.263	1.304	1.337					
Aerobic 8	.866	.888	.870	.901	.880	.906	1.127	1.093	1.071	1.057					
Aerobic 9	1.146	1.158	1.164	1.123	1.204	1.134	1.079	1.140	1.135	1.197					
Aerobic 10	1.423	1.421	1.328	1.342	1.303	1.444	1.560	1.442	1.440	1.467					
Aerobic 11	1.234	1.372	1.251	1.378	1.388	1.314	1.341	1.331	1.327	1.340					
Aerobic 12	1.253	1.176	1.168	1.199	1.180	1.200	1.265	1.308	1.367	1.280					
Aerobic 13	1.554	1.570	1.594	1.572	1.677	1.599	1.607	1.698	1.589	1.656					
Aerobic 14	1.054	1.225	.920	.975	.993	.916	.989	.853	.905	1.025					

Table 10 Arm volume (Liter) of individual subject in aerobic group

	Left arm volume aerobic group (Liter)																			
	Left Pull Pulley							Right Pull Pulley												
	Pre	T1	T2	T3	T4	Pre	T1	T2	T3	T4	Pre	T1	T2	T3	T4					
Aerobic 1	1.042	.959	1.005	1.051	1.028	.907	1.095	1.070	1.062	1.045	1.406	1.317	1.425	1.381	1.313	1.379	1.350	1.317	1.353	1.375
Aerobic 2	1.182	.981	1.089	1.204	1.142	.998	1.172	1.151	1.133	1.094	1.155	1.092	1.157	1.115	1.082	1.247	1.119	1.161	1.150	1.126
Aerobic 3	1.092	1.141	1.149	.973	1.133	1.083	1.110	1.100	1.115	1.139	1.262	1.150	1.134	1.116	1.077	1.149	1.121	1.095	1.149	1.170
Aerobic 4	1.252	1.238	1.197	1.188	1.179	1.335	1.367	1.350	1.315	1.280	1.083	1.222	1.237	1.245	1.092	1.144	1.138	1.155	1.177	1.208
Aerobic 5	1.071	1.115	1.072	1.084	.973	.797	.892	.905	.693	.773	1.462	1.336	1.339	1.252	1.355	1.136	1.434	1.518	1.519	1.456
Aerobic 6	1.159	1.189	.994	.946	.706	1.230	.862	1.155	1.166	1.136	1.278	1.231	1.399	1.256	1.233	1.292	1.251	1.275	1.161	1.319
Aerobic 7	1.485	1.543	1.472	1.469	1.502	1.406	1.378	1.370	1.388	1.495	1.166	1.262	1.195	1.242	1.215	1.070	1.172	1.103	1.228	1.238
Aerobic 8	1.166	1.262	1.195	1.242	1.215	1.070	1.172	1.103	1.228	1.238										

Table 11 Arm volume (Liter) of individual subject in aerobic group

	Left Arm volume aerobic group (Liter)													
	VO max test							Wingate test						
	Pre	T1	T2	T3	T4	Pre	T1	T2	T3	T4				
Aerobic 1	.962	.973	.957	1.122	.970	.975	1.069	1.003	.987	1.002				
Aerobic 2	1.212	1.216	1.170	1.300	1.248	1.427	1.398	1.464	1.423	1.389				
Aerobic 3	.923	.912	.864	.902	.867	.941	1.087	1.043	1.017	1.052				
Aerobic 4	1.048	1.047	1.047	1.168	1.070	1.102	1.164	.934	.682	1.189				
Aerobic 5	.905	.896	.907	.889	.995	.915	.946	.715	.738	.632				
Aerobic 6	.895	1.155	.756	.778	.715	1.161	1.152	1.142	1.156	1.109				
Aerobic 7	.810	1.097	1.092	1.078	1.114	1.161	1.258	1.205	1.184	1.294				
Aerobic 8	.804	.968	.992	.897	.929	.843	.886	.823	.814	.887				
Aerobic 9	1.038	1.080	1.066	1.090	1.135	1.123	1.066	1.092	1.055	1.105				
Aerobic 10	1.577	1.570	1.558	1.626	1.612	1.588	1.472	1.585	1.521	1.570				
Aerobic 11	1.127	1.191	1.169	1.100	1.201	1.213	1.209	1.123	1.137	1.225				
Aerobic 12	1.164	1.208	1.226	1.297	1.246	1.230	1.224	1.174	1.235	1.149				
Aerobic 13	1.515	1.574	1.550	1.587	1.490	1.307	1.198	1.356	1.200	1.394				
Aerobic 14	1.224	1.256	1.285	1.199	1.190	1.288	1.242	1.237	1.225	1.177				

Table 12 Arm volume (Liter) of individual subject in aerobic group

	Right Arm volume aerobic group (Liter)													
	VO max test							Wingate test						
	Pre	T1	T2	T3	T4	Pre	T1	T2	T3	T4				
Aerobic 1	.959	.993	1.013	1.080	1.069	1.144	1.119	1.128	1.182	1.124				
Aerobic 2	1.188	1.150	1.020	1.075	1.157	1.243	1.246	1.254	1.231	1.302				
Aerobic 3	1.144	.946	.974	.879	.951	1.156	1.286	1.262	1.233	1.277				
Aerobic 4	.888	.914	.945	.940	.987	.647	.691	.761	.752	1.172				
Aerobic 5	1.024	.778	.866	1.110	1.210	1.267	1.061	.776	.838	1.012				
Aerobic 6	.950	.894	.756	.817	.768	1.326	1.239	1.207	1.335	1.338				
Aerobic 7	.890	1.262	1.297	1.083	1.190	1.405	1.149	1.450	1.455	1.447				
Aerobic 8	.815	.840	.854	.865	.876	.938	.984	1.004	.925	.803				
Aerobic 9	1.146	1.136	1.251	1.178	1.200	1.196	1.195	1.252	1.200	1.202				
Aerobic 10	1.370	1.354	1.419	1.393	1.508	1.373	1.340	1.405	1.346	1.431				
Aerobic 11	1.335	1.274	1.261	1.224	1.276	1.270	1.278	1.300	1.390	1.292				
Aerobic 12	1.344	1.219	1.212	1.199	1.313	1.302	1.385	1.214	1.468	1.483				
Aerobic 13	1.621	1.558	1.628	1.628	1.576	1.420	1.306	1.727	1.486	1.406				
Aerobic 14	1.221	1.199	1.386	1.216	1.331	1.398	1.352	1.352	1.297	1.330				

Table 13 Leg volume (Liter) of individual subject in aerobic group

	Left Leg volume aerobic group (Liter)													
	VO max test							Wingate test						
	Pre	T1	T2	T3	T4	Pre	T1	T2	T3	T4				
Aerobic 1	2.350	2.703	2.371	2.328	2.251	2.487	2.535	2.487	2.571	2.530				
Aerobic 2	2.523	2.574	2.751	2.720	2.455	2.471	2.519	2.710	2.589	2.572				
Aerobic 3	2.456	2.457	2.385	2.389	2.415	2.807	2.639	2.555	2.787	2.598				
Aerobic 4	2.302	2.367	2.387	2.305	2.429	2.360	2.153	2.250	2.418	2.330				
Aerobic 5	2.117	2.223	1.770	2.329	2.200	2.425	2.463	2.314	2.314	2.425				
Aerobic 6	2.821	2.850	2.781	2.809	2.853	3.212	3.213	3.058	3.345	3.258				
Aerobic 7	3.038	2.593	3.072	3.134	3.267	3.159	3.309	3.164	3.005	3.070				
Aerobic 8	2.245	2.385	2.388	2.445	2.373	2.512	2.523	2.530	2.376	2.570				
Aerobic 9	2.193	2.297	2.420	2.426	2.288	2.422	2.378	2.138	2.494	2.348				
Aerobic 10	3.630	3.626	3.492	3.566	3.765	3.780	3.581	3.631	3.525	3.681				
Aerobic 11	2.991	3.065	3.066	3.040	3.226	2.972	2.863	2.953	3.129	3.008				
Aerobic 12	2.656	2.668	2.814	2.701	2.554	2.805	2.724	2.834	2.831	2.820				
Aerobic 13	3.318	3.482	3.665	3.611	3.422	3.258	3.226	2.943	3.242	3.348				
Aerobic 14	3.128	2.878	2.947	2.944	2.947	3.003	3.081	3.007	3.049	3.020				

Table 14 Leg volume (Liter) of individual subject in aerobic group

	Right Leg volume aerobic group (Liter)													
	VO max test							Wingate test						
	Pre	T1	T2	T3	T4	Pre	T1	T2	T3	T4				
Aerobic 1	2.538	2.610	2.610	2.385	2.585	2.467	2.667	2.582	2.640	2.680				
Aerobic 2	2.650	2.438	2.315	1.426	2.282	2.752	2.642	2.839	2.900	2.854				
Aerobic 3	2.131	2.405	2.506	2.284	2.241	2.871	2.823	2.491	2.600	2.782				
Aerobic 4	2.446	2.425	2.453	2.438	2.462	2.489	2.210	2.207	2.407	2.494				
Aerobic 5	2.258	2.270	2.122	2.323	2.254	2.246	2.279	2.284	2.173	2.284				
Aerobic 6	2.972	2.840	2.782	2.845	2.854	3.197	3.051	3.127	3.212	3.271				
Aerobic 7	2.933	3.172	3.282	3.082	3.200	3.156	3.122	3.148	3.356	3.258				
Aerobic 8	2.393	2.271	2.192	2.265	2.320	2.367	2.580	2.501	2.703	2.560				
Aerobic 9	2.433	2.378	2.358	2.437	2.303	2.344	2.158	2.227	2.282	2.354				
Aerobic 10	3.802	3.824	3.727	3.648	3.680	3.667	3.586	3.441	3.548	3.471				
Aerobic 11	2.990	2.586	2.962	2.878	3.145	2.642	3.060	2.997	3.066	2.942				
Aerobic 12	2.650	2.573	2.854	2.657	2.668	2.938	2.713	2.959	2.852	2.914				
Aerobic 13	3.473	3.580	3.370	3.577	3.426	3.271	3.218	3.417	3.454	3.496				
Aerobic 14	3.040	2.998	3.027	3.012	3.001	3.134	2.936	2.968	3.090	2.792				

Table 15 Arm volume (Liter) of individual subject in anaerobic group

	Left arm volume anaerobic group (Liter)														
	Left Inflated Blood Pressure Cuff							Right Inflated Blood Pressure Cuff							
	Pre	T1	T2	T3	T4	Pre	T1	T2	T3	T4	Pre	T1	T2	T3	T4
Anaerobic 1	1.308	1.316	1.300	1.288	1.311	1.331	1.325	1.341	1.375	1.381	1.331	1.325	1.341	1.375	1.381
Anaerobic 2	1.092	1.237	1.192	1.186	1.212	1.063	1.177	1.239	1.218	1.261	1.063	1.177	1.239	1.218	1.261
Anaerobic 3	1.156	1.208	1.182	1.174	1.197	1.159	1.275	1.315	1.270	1.262	1.159	1.275	1.315	1.270	1.262
Anaerobic 4	1.182	1.342	1.327	1.303	1.334	1.327	1.250	1.271	1.298	1.301	1.327	1.250	1.271	1.298	1.301
Anaerobic 5	1.139	1.148	1.122	1.102	1.149	1.200	1.139	1.160	1.182	1.194	1.200	1.139	1.160	1.182	1.194
Anaerobic 6	1.085	.944	.972	1.001	1.063	1.085	1.084	1.112	1.125	1.133	1.085	1.084	1.112	1.125	1.133
Anaerobic 7	1.089	1.136	1.124	1.112	1.134	1.217	1.182	1.203	1.230	1.239	1.217	1.182	1.203	1.230	1.239
Anaerobic 8	1.180	1.236	1.181	1.169	1.215	1.195	1.072	1.143	1.148	1.184	1.195	1.072	1.143	1.148	1.184
Anaerobic 9	1.609	1.776	1.681	1.644	1.717	1.752	1.666	1.679	1.733	1.714	1.752	1.666	1.679	1.733	1.714
Anaerobic 10	1.186	1.346	1.183	1.204	1.325	1.251	1.279	1.240	1.296	1.285	1.251	1.279	1.240	1.296	1.285
Anaerobic 11	.794	.839	.788	.782	.813	.622	.708	.643	.675	.992	.622	.708	.643	.675	.992
Anaerobic 12	.802	.892	.945	.894	.914	.822	.873	.804	.841	.851	.822	.873	.804	.841	.851
Anaerobic 13	.897	.874	.924	.962	.980	1.005	.930	1.000	.921	.929	1.005	.930	1.000	.921	.929
Anaerobic 14	1.253	1.276	1.306	1.350	1.346	1.174	1.300	1.276	1.322	1.267	1.174	1.300	1.276	1.322	1.267

Table 16 Arm volume (Liter) of individual subject in anaerobic group

	Left arm volume anaerobic group (Liter)													
	Left Pull Pulley							Right Pull Pulley						
	Pre	T1	T2	T3	T4	Pre	T1	T2	T3	T4				
Anaerobic 1	1.385	1.281	1.391	1.389	1.361	1.340	1.360	1.322	1.305	1.443				
Anaerobic 2	1.327	1.294	1.233	1.281	1.225	1.284	1.143	1.260	1.176	1.173				
Anaerobic 3	1.235	1.112	1.248	1.220	1.171	1.144	1.225	1.218	1.201	1.233				
Anaerobic 4	1.367	1.216	1.183	1.152	1.204	1.318	1.180	1.235	1.260	1.330				
Anaerobic 5	1.098	1.192	1.153	1.128	1.116	1.208	1.149	1.172	1.228	1.184				
Anaerobic 6	1.150	1.140	1.172	1.130	1.121	1.136	1.153	1.148	1.095	1.082				
Anaerobic 7	1.127	1.213	1.202	1.195	1.177	1.301	1.111	1.200	1.252	1.293				
Anaerobic 8	1.096	1.118	1.188	1.171	1.089	1.072	1.249	1.154	1.104	1.202				
Anaerobic 9	1.624	1.607	1.659	1.557	1.691	1.602	1.470	1.511	1.597	1.670				
Anaerobic 10	1.074	1.091	1.102	1.006	1.128	1.162	1.158	1.070	1.122	1.136				
Anaerobic 11	.816	.730	.835	.748	.779	.852	.759	.822	.871	.869				
Anaerobic 12	.985	1.047	1.028	1.002	.939	.963	1.066	1.050	.980	1.089				
Anaerobic 13	.734	.858	.905	.788	.719	.800	.795	.840	.766	.773				
Anaerobic 14	1.361	1.309	1.348	1.286	1.307	1.360	1.375	1.353	1.404	1.202				

Table 17 Arm volume (Liter) of individual subject in anaerobic group

	Left Arm volume anaerobic group (Liter)													
	VO max test							Wingate test						
	Pre	T1	T2	T3	T4	Pre	T1	T2	T3	T4				
Anaerobic 1	1.323	1.370	1.404	1.360	1.345	1.348	1.351	1.205	1.287	1.317				
Anaerobic 2	1.120	1.110	1.064	1.087	1.087	.982	1.111	.743	1.066	1.100				
Anaerobic 3	1.081	1.268	1.247	1.090	1.104	1.183	1.187	1.218	1.228	1.220				
Anaerobic 4	1.000	1.136	1.105	1.110	1.113	1.311	1.260	1.322	1.410	1.288				
Anaerobic 5	1.109	.824	.745	.793	.872	1.076	1.147	1.166	.671	1.111				
Anaerobic 6	.873	.816	.749	.839	.825	1.024	1.003	.910	.905	.920				
Anaerobic 7	.890	.803	.794	.854	.732	1.167	1.201	1.079	1.208	1.182				
Anaerobic 8	1.150	1.118	1.131	1.240	1.128	1.154	1.289	1.297	1.204	1.348				
Anaerobic 9	1.506	1.576	1.631	1.576	1.637	1.587	1.544	1.640	1.594	1.491				
Anaerobic 10	1.280	1.224	1.264	1.171	1.191	1.184	1.266	1.188	1.105	1.114				
Anaerobic 11	.873	.900	.970	.972	1.088	.992	.927	1.037	1.051	1.038				
Anaerobic 12	.921	.922	1.081	1.072	1.009	1.006	.994	.950	.989	.950				
Anaerobic 13	.944	.984	.972	1.026	.940	.936	.894	.886	.895	.904				
Anaerobic 14	1.305	1.268	1.158	1.219	1.298	1.275	1.261	1.244	1.300	1.221				

Table18 Arm volume (Liter) of individual subject in anaerobic group

	Right Arm volume anaerobic group (Liter)													
	VO max test							Wingate test						
	Pre	T1	T2	T3	T4	Pre	T1	T2	T3	T4				
Anaerobic 1	1.375	1.386	1.414	1.265	1.360	1.440	1.410	1.337	1.437	1.365				
Anaerobic 2	.965	1.134	1.006	1.034	1.059	1.044	1.244	.938	1.275	1.078				
Anaerobic 3	1.120	1.153	1.226	1.105	1.083	1.064	1.106	1.140	1.206	1.047				
Anaerobic 4	.900	.938	1.053	1.060	1.048	1.214	1.081	1.086	1.181	1.119				
Anaerobic 5	1.109	.687	1.101	.662	.785	1.227	1.327	1.374	1.245	1.353				
Anaerobic 6	.885	.855	.849	.859	.950	1.000	1.063	.988	1.000	1.025				
Anaerobic 7	.916	.924	.917	.860	.799	1.146	1.126	1.181	1.194	1.146				
Anaerobic 8	1.149	1.171	1.176	1.180	1.130	1.469	1.233	1.320	1.298	1.397				
Anaerobic 9	1.764	1.566	1.676	1.815	1.611	1.644	1.656	1.668	1.651	1.728				
Anaerobic 10	1.293	1.204	1.096	1.246	1.206	1.182	1.160	1.197	1.335	1.198				
Anaerobic 11	1.234	1.078	1.200	1.067	1.105	1.105	1.018	1.047	1.004	1.027				
Anaerobic 12	1.021	1.076	1.146	1.076	1.078	1.040	1.031	.983	1.119	1.047				
Anaerobic 13	.945	.996	1.059	1.083	1.047	.896	.931	.986	1.013	1.022				
Anaerobic 14	1.001	1.124	1.124	1.249	1.109	1.161	1.119	1.076	1.176	1.122				

Table 19 Leg volume (Liter) of individual subject in anaerobic group

	Left Leg volume anaerobic group (Liter)													
	VO max test							Wingate test						
	Pre	T1	T2	T3	T4	Pre	T1	T2	T3	T4				
Anaerobic 1	3.010	3.018	3.000	2.856	3.045	2.907	3.146	2.864	2.896	2.938				
Anaerobic 2	2.927	2.834	2.681	2.473	2.488	2.583	2.591	2.550	2.790	2.629				
Anaerobic 3	2.500	2.802	2.877	2.698	2.750	2.475	2.605	2.334	2.419	2.482				
Anaerobic 4	2.152	2.296	2.131	2.422	2.255	2.300	2.475	2.690	2.286	2.311				
Anaerobic 5	2.775	2.307	2.811	2.696	2.616	2.729	2.936	2.834	2.930	2.835				
Anaerobic 6	2.226	2.320	2.375	2.456	2.447	2.371	1.855	2.290	2.367	2.280				
Anaerobic 7	2.761	2.800	2.824	2.962	2.434	2.775	2.874	2.749	2.809	2.818				
Anaerobic 8	2.600	2.665	2.912	2.596	2.745	2.908	2.731	2.730	2.751	2.850				
Anaerobic 9	3.171	3.198	3.162	3.211	3.368	3.574	3.290	3.298	3.324	3.430				
Anaerobic 10	2.380	2.434	2.462	2.537	2.564	2.693	2.855	2.599	2.596	2.750				
Anaerobic 11	2.336	2.352	2.258	2.323	2.278	2.559	2.488	2.524	2.488	2.477				
Anaerobic 12	2.243	2.360	2.345	2.314	2.387	2.344	2.363	2.618	2.466	2.499				
Anaerobic 13	2.418	2.448	2.411	2.423	2.497	2.502	2.269	2.278	2.269	2.528				
Anaerobic 14	2.658	2.541	2.503	2.535	2.623	2.674	2.705	2.641	2.670	2.633				

Table 20 Leg volume (Liter) of individual subject in anaerobic group

	Right Leg volume anaerobic group (Liter)													
	VO max test							Wingate test						
	Pre	T1	T2	T3	T4	Pre	T1	T2	T3	T4				
Anaerobic 1	2.883	2.913	3.062	3.017	2.880	2.853	2.876	2.804	2.833	2.812				
Anaerobic 2	2.540	2.435	2.690	2.606	2.536	2.660	2.672	2.704	2.710	2.693				
Anaerobic 3	2.750	2.715	2.632	2.731	2.528	2.491	2.465	2.395	2.391	2.460				
Anaerobic 4	2.290	2.260	2.398	2.324	2.306	2.313	2.274	2.561	2.346	2.599				
Anaerobic 5	2.739	3.025	2.954	2.996	2.867	2.722	2.959	2.925	3.013	2.760				
Anaerobic 6	2.314	2.410	2.331	2.270	2.081	1.948	2.445	2.350	2.420	2.564				
Anaerobic 7	2.745	2.870	2.673	2.522	2.389	2.732	2.784	2.814	2.758	2.684				
Anaerobic 8	2.919	2.660	2.837	2.960	3.005	2.971	2.944	2.936	2.922	2.930				
Anaerobic 9	3.473	3.264	3.191	3.428	3.501	3.514	3.589	3.377	3.623	3.773				
Anaerobic 10	2.558	2.523	2.602	2.386	2.47	2.544	2.795	2.453	2.591	2.857				
Anaerobic 11	2.495	2.094	2.546	2.512	2.532	2.372	2.445	2.347	2.517	2.434				
Anaerobic 12	2.329	2.383	2.276	2.305	2.343	2.397	2.177	2.418	2.400	2.440				
Anaerobic 13	2.483	2.675	2.589	2.566	2.578	2.606	2.469	2.596	2.538	2.603				
Anaerobic 14	2.675	2.615	2.488	2.640	2.542	2.697	2.739	2.650	2.636	2.520				

Table 21 Arm volume per body weight (Liter/kg) of individual subject in control group

	Left arm volume per body weight control group (Liter/kg)											
	Left Inflated Blood Pressure Cuff						Right Inflated Blood Pressure Cuff					
	Pre	T1	T2	T3	T4	Pre	T1	T2	T3	T4		
Control 1	.0192	.0219	.0214	.0212	.0205	.0217	.0207	.0200	.0195	.0190		
Control 2	.0122	.0136	.0132	.0125	.0123	.0122	.0117	.0119	.0120	.0120		
Control 3	.0194	.0191	.0193	.0194	.0192	.0204	.0213	.0216	.0212	.0207		
Control 4	.0205	.0208	.0210	.0209	.0208	.0200	.0195	.0200	.0192	.0189		
Control 5	.0121	.0141	.0137	.0132	.0126	.0122	.0127	.0128	.0124	.0123		
Control 6	.0157	.0129	.0133	.0136	.0143	.0142	.0147	.0149	.0146	.0142		
Control 7	.0136	.0140	.0136	.0134	.0135	.0137	.0157	.0150	.0146	.0142		
Control 8	.0190	.0178	.0180	.0182	.0187	.0163	.0175	.0171	.0170	.0170		
Control 9	.0208	.0192	.0196	.0199	.0202	.0156	.0196	.0188	.0185	.0177		
Control 10	.0180	.0183	.0185	.0183	.0181	.0191	.0200	.0198	.0191	.0192		
Control 11	.0207	.0194	.0197	.0201	.0206	.0189	.0177	.0179	.0184	.0182		
Control 12	.0186	.0192	.0195	.0193	.0189	.0187	.0192	.0195	.0190	.0190		

Table 22 Arm volume per body weight (Liter/kg) of individual subject in control group

	Left arm volume per body weight control group (Liter/kg)											
	Left Pull Pulley						Right Pull Pulley					
	Pre	T1	T2	T3	T4	Pre	T1	T2	T3	T4		
Control 1	.0219	.0215	.0213	.0210	.0214	.0202	.0222	.0215	.0210	.0203		
Control 2	.0145	.0144	.0142	.0138	.0145	.0135	.0138	.0135	.0130	.0128		
Control 3	.0191	.0206	.0200	.0196	.0191	.0206	.0223	.0218	.0214	.0205		
Control 4	.0204	.0212	.0209	.0205	.0204	.0209	.0203	.0211	.0208	.0205		
Control 5	.0134	.0132	.0129	.0127	.0134	.0131	.0139	.0137	.0134	.0130		
Control 6	.0165	.0167	.0162	.0168	.0165	.0165	.0168	.0166	.0164	.0163		
Control 7	.0094	.0125	.0122	.0117	.0111	.0102	.0110	.0107	.0105	.0086		
Control 8	.0187	.0173	.0176	.0185	.0187	.0191	.0188	.0190	.0187	.0192		
Control 9	.0190	.0181	.0183	.0186	.0188	.0196	.0190	.0187	.0190	.0195		
Control 10	.0206	.0184	.0191	.0195	.0201	.0186	.0209	.0204	.0200	.0195		
Control 11	.0165	.0185	.0180	.0174	.0166	.0176	.0186	.0182	.0180	.0176		
Control 12	.0158	.0157	.0155	.0157	.0158	.0157	.0163	.0158	.0154	.0151		

Table 23 Arm volume per body weight (Liter/kg) of individual subject in control group

	Left Arm volume per body weight control group (Liter/kg)											
	VO max test						Wingate test					
	Pre	T1	T2	T3	T4	Pre	T1	T2	T3	T4		
Control 1	.0206	.0213	.0209	.0203	.0212	.0212	.0217	.0216	.0199	.0200		
Control 2	.0188	.0135	.0188	.0124	.0121	.0096	.0100	.0108	.0113	.0115		
Control 3	.0197	.0190	.0184	.0178	.0177	.0173	.0194	.0189	.0193	.0195		
Control 4	.0176	.0189	.0187	.0196	.0186	.0181	.0200	.0185	.0195	.0193		
Control 5	.0163	.0134	.0119	.0112	.0120	.0120	.0112	.0156	.0154	.0173		
Control 6	.0214	.0157	.0219	.0205	.0202	.0149	.0165	.0140	.0117	.0134		
Control 7	.0131	.0143	.0121	.0148	.0137	.0127	.0110	.0123	.0111	.0123		
Control 8	.0179	.0189	.0187	.0167	.0167	.0182	.0170	.0167	.0177	.0177		
Control 9	.0184	.0185	.0176	.0192	.0174	.0189	.0186	.0179	.0178	.0180		
Control 10	.0190	.0191	.0193	.0201	.0199	.0194	.0184	.0194	.0198	.0187		
Control 11	.0181	.0204	.0187	.0344	.0184	.0194	.0176	.0176	.0184	.0186		
Control 12	.0178	.0146	.0130	.0122	.0132	.0132	.0123	.0171	.0169	.0190		

Table 24 Arm volume per body weight (Liter/kg) of individual subject in control group

	Right Arm volume per body weight control group (Liter/kg)											
	VO max test						Wingate test					
	Pre	T1	T2	T3	T4	Pre	T1	T2	T3	T4		
Control 1	.0180	.0225	.0209	.0226	.0216	.0231	.0213	.0218	.0205	.0197		
Control 2	.0208	.0159	.0184	.0116	.0117	.0100	.0110	.0120	.0116	.0127		
Control 3	.0198	.0195	.0209	.0206	.0190	.0197	.0194	.0194	.0172	.0198		
Control 4	.0194	.0222	.0214	.0210	.0204	.0203	.0211	.0234	.0201	.0219		
Control 5	.0187	.0160	.0120	.0111	.0125	.0121	.0117	.0107	.0125	.0147		
Control 6	.0237	.0157	.0227	.0196	.0200	.0152	.0179	.0178	.0125	.0151		
Control 7	.0116	.0111	.0144	.0154	.0148	.0147	.0150	.0122	.0140	.0161		
Control 8	.0161	.0174	.0179	.0170	.0168	.0176	.0170	.0192	.0176	.0196		
Control 9	.0172	.0181	.0164	.0166	.0173	.0175	.0179	.0187	.0183	.0166		
Control 10	.0198	.0184	.0208	.0200	.0183	.0192	.0198	.0196	.0204	.0200		
Control 11	.0199	.0176	.0187	.0187	.0208	.0185	.0185	.0185	.0190	.0198		
Control 12	.0205	.0175	.0131	.0121	.0137	.0133	.0129	.0117	.0137	.0161		

Table 25 Leg volume per body weigh (Liter/kg) of individual subject in control group

	Left Leg volume per body weight control group (Liter/kg)											
	VO max test						Wingate test					
	Pre	T1	T2	T3	T4	Pre	T1	T2	T3	T4		
Control 1	.0430	.0410	.0424	.0416	.0416	.0420	.0396	.0409	.0442	.0441		
Control 2	.0366	.0372	.0357	.0355	.0355	.0303	.0334	.0334	.0316	.0319		
Control 3	.0444	.0436	.0439	.0431	.0431	.0418	.0418	.0491	.0462	.0458		
Control 4	.0431	.0428	.0444	.0443	.0443	.0459	.0448	.0460	.0467	.0465		
Control 5	.0307	.0319	.0301	.0306	.0306	.0315	.0305	.0310	.0390	.0303		
Control 6	.0440	.0440	.0422	.0436	.0436	.0429	.0413	.0322	.0426	.0415		
Control 7	.0436	.0429	.0451	.0433	.0433	.0441	.0453	.0469	.0415	.0457		
Control 8	.0355	.0382	.0369	.0372	.0372	.0402	.0392	.0382	.0406	.0416		
Control 9	.0502	.0445	.0465	.0470	.0470	.0471	.0448	.0463	.0485	.0479		
Control 10	.0466	.0457	.0461	.0472	.0472	.0468	.0467	.0446	.0455	.0452		
Control 11	.0417	.0427	.0436	.0427	.0427	.0436	.0404	.0412	.0445	.0283		
Control 12	.0337	.0350	.0330	.0336	.0336	.0346	.0335	.0340	.0429	.0333		

Table 26 Leg volume per body weight (Liter/kg) of individual subject in control group

	Right Leg volume per body weight control group (Liter/kg)											
	VO max test						Wingate test					
	Pre	T1	T2	T3	T4	Pre	T1	T2	T3	T4		
Control 1	.0414	.0426	.0445	.0441	.0451	.0417	.0432	.0443	.0440	.0447		
Control 2	.0337	.0391	.0389	.0347	.0288	.0299	.0298	.0304	.0311	.0293		
Control 3	.0452	.0468	.0491	.0448	.0430	.0472	.0442	.0499	.0447	.0443		
Control 4	.0448	.0482	.0493	.0490	.0476	.0460	.0457	.0466	.0484	.0505		
Control 5	.0297	.0303	.0299	.0304	.0307	.0323	.0287	.0287	.0323	.0301		
Control 6	.0398	.0440	.0384	.0411	.0417	.0347	.0399	.0396	.0378	.0428		
Control 7	.0403	.0402	.0420	.0414	.0415	.0430	.0415	.0434	.0411	.0442		
Control 8	.0374	.0386	.0376	.0401	.0410	.0424	.0421	.0406	.0417	.0461		
Control 9	.0451	.0469	.0452	.0472	.0448	.0453	.0452	.0476	.0475	.0450		
Control 10	.0449	.0474	.0452	.0474	.0445	.0465	.0464	.0441	.0448	.0455		
Control 11	.0419	.0409	.0461	.0438	.0448	.0446	.0430	.0471	.0462	.0370		
Control 12	.0326	.0333	.0328	.0334	.0337	.0357	.0315	.0315	.0235	.0331		

Table 27 Arm volume per body weight (Liter/kg) of individual subject in aerobic group

	Left arm volume per body weight aerobic group (Liter/kg)													
	Left Inflated Blood Pressure Cuff							Right Inflated Blood Pressure Cuff						
	Pre	T1	T2	T3	T4	Pre	T1	T2	T3	T4				
Aerobic 1	.0177	.0169	.0174	.0181	.0175	.0189	.0112	.0128	.0134	.0146				
Aerobic 2	.0237	.0224	.0219	.0220	.0225	.0215	.0228	.0226	.0224	.0221				
Aerobic 3	.0190	.0163	.0174	.0180	.0203	.0176	.0154	.0166	.0173	.0171				
Aerobic 4	.0187	.0198	.0195	.0193	.0188	.0207	.0204	.0210	.0207	.0211				
Aerobic 5	.0196	.0186	.0193	.0193	.0185	.0201	.0194	.0199	.0189	.0192				
Aerobic 6	.0203	.0187	.0185	.0192	.0189	.0203	.0180	.0182	.0187	.0194				
Aerobic 7	.0198	.0211	.0213	.0209	.0206	.0217	.0196	.0200	.0206	.0212				
Aerobic 8	.0162	.0165	.0163	.0169	.0165	.0170	.0211	.0205	.0201	.0197				
Aerobic 9	.0216	.0218	.0220	.0212	.0227	.0214	.0204	.0215	.0214	.0226				
Aerobic 10	.0182	.0182	.0170	.0172	.0167	.0185	.0200	.0185	.0185	.0188				
Aerobic 11	.0193	.0215	.0196	.0216	.0218	.0206	.0210	.0209	.0208	.0210				
Aerobic 12	.0208	.0195	.0194	.0199	.0196	.0199	.0210	.0217	.0227	.0213				
Aerobic 13	.0199	.0201	.0204	.0201	.0214	.0204	.0205	.0217	.0203	.0212				
Aerobic 14	.0162	.0188	.0142	.0150	.0153	.0141	.0152	.0131	.0139	.0158				

Table 28 Arm volume per body weight (Liter/kg) of individual subject in aerobic group

	Left arm volume per body weight aerobic group (Liter/kg)														
	Left Pull Pulley							Right Pull Pulley							
	Pre	T1	T2	T3	T4	Pre	T1	T2	T3	T4	Pre	T1	T2	T3	T4
Aerobic 1	.0185	.0170	.0179	.0187	.0183	.0161	.0194	.0190	.0189	.0186	.0194	.0190	.0189	.0189	.0186
Aerobic 2	.0219	.0205	.0222	.0215	.0205	.0215	.0210	.0205	.0211	.0214	.0215	.0205	.0211	.0214	.0214
Aerobic 3	.0191	.0159	.0175	.0195	.0185	.0161	.0190	.0186	.0183	.0177	.0190	.0186	.0183	.0183	.0177
Aerobic 4	.0201	.0190	.0201	.0194	.0188	.0217	.0195	.0202	.0200	.0196	.0217	.0202	.0200	.0200	.0196
Aerobic 5	.0192	.0200	.0202	.0171	.0199	.0190	.0195	.0193	.0196	.0200	.0190	.0193	.0196	.0196	.0200
Aerobic 6	.0204	.0185	.0183	.0180	.0174	.0185	.0181	.0177	.0185	.0189	.0185	.0177	.0185	.0185	.0189
Aerobic 7	.0198	.0196	.0189	.0188	.0187	.0211	.0216	.0214	.0208	.0203	.0211	.0214	.0208	.0208	.0203
Aerobic 8	.0203	.0229	.0232	.0233	.0204	.0214	.0213	.0216	.0220	.0226	.0214	.0216	.0220	.0220	.0226
Aerobic 9	.0202	.0210	.0202	.0205	.0184	.0150	.0168	.0171	.0131	.0146	.0150	.0171	.0131	.0131	.0146
Aerobic 10	.0187	.0171	.0172	.0161	.0174	.0146	.0184	.0195	.0195	.0187	.0146	.0195	.0195	.0195	.0187
Aerobic 11	.0182	.0186	.0156	.0148	.0111	.0193	.0135	.0181	.0183	.0178	.0193	.0181	.0183	.0183	.0178
Aerobic 12	.0212	.0204	.0232	.0209	.0205	.0215	.0208	.0212	.0193	.0219	.0215	.0212	.0193	.0193	.0219
Aerobic 13	.0190	.0197	.0188	.0188	.0192	.0180	.0176	.0175	.0177	.0191	.0180	.0175	.0177	.0177	.0191
Aerobic 14	.0179	.0194	.0184	.0191	.0187	.0165	.0180	.0170	.0189	.0190	.0165	.0180	.0170	.0189	.0190

Table 29 Arm volume per body weight (Liter/kg) of individual subject in aerobic group

	Left Arm volume per body weight aerobic group (Liter/kg)												
	VO max test						Wingate test						
	Pre	T1	T2	T3	T4	Pre	T1	T2	T3	T4			
Aerobic 1	.0171	.0173	.0170	.0199	.0172	.0173	.0190	.0178	.0175	.0178	.0178	.0175	.0178
Aerobic 2	.0189	.0189	.0182	.0202	.0194	.0222	.0218	.0228	.0222	.0216	.0228	.0222	.0216
Aerobic 3	.0149	.0148	.0140	.0146	.0140	.0152	.0176	.0169	.0165	.0170	.0169	.0165	.0170
Aerobic 4	.0182	.0182	.0182	.0203	.0186	.0192	.0202	.0162	.0119	.0200	.0162	.0119	.0200
Aerobic 5	.0159	.0157	.0159	.0156	.0175	.0161	.0166	.0125	.0129	.0111	.0125	.0129	.0111
Aerobic 6	.0144	.0186	.0122	.0125	.0125	.0187	.0186	.0184	.0186	.0179	.0184	.0186	.0179
Aerobic 7	.0128	.0174	.0173	.0171	.0176	.0184	.0199	.0191	.0187	.0205	.0191	.0187	.0205
Aerobic 8	.0151	.0181	.0186	.0168	.0174	.0158	.0166	.0154	.0152	.0166	.0154	.0152	.0166
Aerobic 9	.0196	.0204	.0201	.0206	.0214	.0212	.0201	.0206	.0199	.0208	.0206	.0199	.0208
Aerobic 10	.0202	.0201	.0200	.0208	.0207	.0204	.0189	.0203	.0195	.0201	.0203	.0195	.0201
Aerobic 11	.0177	.0187	.0183	.0172	.0188	.0190	.0189	.0176	.0178	.0192	.0176	.0178	.0192
Aerobic 12	.0193	.0201	.0204	.0215	.0207	.0204	.0203	.0195	.0205	.0191	.0195	.0205	.0191
Aerobic 13	.0194	.0201	.0198	.0203	.0191	.0167	.0153	.0173	.0153	.0178	.0173	.0153	.0178
Aerobic 14	.0188	.0193	.0198	.0184	.0183	.0198	.0191	.0190	.0188	.0187	.0190	.0188	.0187

Table 30 Arm volume per body weight (Liter/kg) of individual subject in aerobic group

	Right Arm volume per body weight aerobic group (Liter/kg)													
	VO max test							Wingate test						
	Pre	T1	T2	T3	T4	Pre	T1	T2	T3	T4				
Aerobic 1	.0170	.0176	.0180	.0192	.0190	.0203	.0199	.0200	.0210	.0200				
Aerobic 2	.0185	.0179	.0159	.0167	.0180	.0194	.0194	.0195	.0192	.0203				
Aerobic 3	.0185	.0153	.0158	.0142	.0154	.0187	.0208	.0204	.0200	.0207				
Aerobic 4	.0154	.0159	.0164	.0163	.0172	.0113	.0120	.0132	.0131	.0204				
Aerobic 5	.0180	.0136	.0152	.0195	.0212	.0222	.0186	.0136	.0147	.0178				
Aerobic 6	.0153	.0144	.0122	.0132	.0124	.0214	.200	.0195	.0215	.0216				
Aerobic 7	.0141	.0200	.0205	.0171	.0188	.0222	.0229	.0229	.0230	.0229				
Aerobic 8	.0153	.0157	.0160	.0162	.0164	.0176	.0184	.0188	.0173	.0150				
Aerobic 9	.0216	.0214	.0236	.0222	.0226	.0226	.0225	.0236	.0226	.0227				
Aerobic 10	.0176	.0174	.0182	.0179	.0193	.0176	.0172	.0180	.0173	.0183				
Aerobic 11	.0209	.020	.0198	.0192	.0200	.0199	.0200	.0204	.218	.0203				
Aerobic 12	.0223	.0202	.0201	.0199	.0218	.0216	.0230	.0202	.0244	.0246				
Aerobic 13	.0207	.0199	.0208	.0208	.0202	.0182	.0167	.0221	.0190	.0180				
Aerobic 14	.0188	.0184	.0213	.0187	.0205	.0215	.0208	.0208	.0200	.0205				

Table 31 Leg volume per body weight (Liter/kg) of individual subject in aerobic group

	Left Leg volume per body weight aerobic group (Liter/kg)													
	VO max test							Wingate test						
	Pre	T1	T2	T3	T4	Pre	T1	T2	T3	T4				
Aerobic 1	.0417	.0480	.0421	.0413	.040	.0442	.0450	.0442	.0457	.0449				
Aerobic 2	.0393	.0104	.0429	.0424	.0382	.0385	.0392	.0266	.0403	.0401				
Aerobic 3	.0397	.0398	.0386	.0387	.0391	.0154	.0427	.0413	.0451	.0420				
Aerobic 4	.0400	.0412	.0415	.0401	.0422	.0410	.0374	.0391	.0421	.0405				
Aerobic 5	.0371	.0390	.0311	.0409	.386	.0431	.0432	.0406	.0406	.0425				
Aerobic 6	.0455	.0460	.0449	.0453	.046	.0518	.0518	.0493	.0540	.0525				
Aerobic 7	.0481	.0410	.0486	.0496	.0517	.0500	.0524	.0501	.0475	.0486				
Aerobic 8	.0420	.0447	.0447	.0458	.0444	.0470	.0472	.0474	.0445	.0481				
Aerobic 9	.0414	.0433	.0457	.0458	.0432	.0457	.0449	.0403	.0471	.0443				
Aerobic 10	.0465	.0465	.0448	.0457	.0483	.0485	.0459	.0466	.0452	.0472				
Aerobic 11	.0469	.0480	.0481	.0476	.0506	.0466	.0449	.0463	.0490	.0471				
Aerobic 12	.0441	.0443	.0457	.0449	.0424	.0466	.0452	.0471	.0470	.0468				
Aerobic 13	.0424	.0445	.0469	.0462	.0438	.0417	.0413	.0376	.0415	.0428				
Aerobic 14	.0481	.0443	.0453	.0453	.0453	.0462	.0474	.0463	.0468	.0465				

Table 32 Leg volume per body weight (Liter/kg) of individual subject in aerobic group

	Right Leg volume per body weight aerobic group (Liter/kg)												
	VO max test						Wingate test						
	Pre	T1	T2	T3	T4	Pre	T1	T2	T3	T4			
Aerobic 1	.0451	.0464	.0464	.0305	.0459	.0438	.0474	.0459	.0469	.0476			
Aerobic 2	.0413	.0380	.0361	.0222	.0355	.0429	.0412	.0442	.0452	.0445			
Aerobic 3	.0345	.0389	.0406	.0370	.0363	.0465	.0457	.0403	.0421	.0450			
Aerobic 4	.0425	.0422	.0427	.0424	.0428	.0433	.0384	.0384	.0419	.0434			
Aerobic 5	.0396	.0398	.0372	.0408	.0395	.0394	.0400	.0401	.0381	.0401			
Aerobic 6	.0479	.0458	.0449	.0459	.0460	.0516	.0492	.0504	.0518	.0528			
Aerobic 7	.0464	.0502	.0519	.0488	.0506	.0499	.0494	.0498	.0531	.0516			
Aerobic 8	.0448	.0425	.0410	.0424	.0434	.0443	.0483	.0468	.0506	.0479			
Aerobic 9	.0459	.0449	.0445	.0460	.0435	.0442	.0407	.0420	.0431	.0444			
Aerobic 10	.0487	.0490	.0478	.0468	.0472	.0470	.0460	.0441	.0455	.0445			
Aerobic 11	.0469	.0405	.0464	.0451	.0493	.0414	.0480	.0470	.0481	.0461			
Aerobic 12	.0440	.0427	.0474	.0441	.0443	.0488	.0451	.0492	.0474	.0484			
Aerobic 13	.0444	.0458	.0431	.0457	.0438	.0418	.0412	.0437	.0442	.0447			
Aerobic 14	.0468	.0461	.0466	.0463	.0462	.0482	.0452	.0457	.0475	.0430			

Table 33 Arm volume per body weight (Liter/kg) of individual subject in anaerobic group

	Left arm volume per body weight anaerobic group (Liter/kg)								Right Inflated Blood Pressure Cuff				
	Left Inflated Blood Pressure Cuff				Right Inflated Blood Pressure Cuff				Pre	T1	T2	T3	T4
	Pre	T1	T2	T3	T4	Pre	T1	T2					
Anaerobic 1	.0201	.0202	.0200	.0198	.0202	.0205	.0204	.0206	.0212	.0212	.0212	.0212	.0212
Anaerobic 2	.0173	.0196	.0189	.0188	.0192	.0169	.0187	.0197	.0193	.0193	.0200	.0200	.0200
Anaerobic 3	.0186	.0195	.0191	.0189	.0193	.0187	.0206	.0212	.0205	.0205	.0204	.0204	.0204
Anaerobic 4	.0200	.0227	.0225	.0221	.0226	.0225	.0212	.0215	.0220	.0220	.0221	.0221	.0221
Anaerobic 5	.0170	.0171	.0167	.0164	.0171	.0179	.0170	.0173	.0176	.0176	.0178	.0178	.0178
Anaerobic 6	.0197	.0172	.0177	.0182	.0193	.0197	.0197	.0202	.0205	.0205	.0206	.0206	.0206
Anaerobic 7	.0170	.0177	.0175	.0173	.0177	.0190	.0184	.0187	.0192	.0192	.0193	.0193	.0193
Anaerobic 8	.0190	.0199	.0190	.0189	.0196	.0193	.0173	.0184	.0185	.0185	.0191	.0191	.0191
Anaerobic 9	.0207	.0229	.0217	.0212	.0221	.0226	.0215	.0216	.0223	.0223	.0221	.0221	.0221
Anaerobic 10	.0198	.0224	.0197	.0201	.0221	.0208	.0213	.0207	.0216	.0216	.0214	.0214	.0214
Anaerobic 11	.0137	.0145	.0136	.0135	.0140	.0107	.0122	.0111	.0116	.0116	.0171	.0171	.0171
Anaerobic 12	.0143	.0159	.0169	.0160	.0163	.0147	.0156	.0144	.0150	.0150	.0152	.0152	.0152
Anaerobic 13	.0166	.0162	.0171	.0178	.0181	.0186	.0172	.0185	.0171	.0171	.0172	.0172	.0172
Anaerobic 14	.0199	.0203	.0207	.0214	.0214	.0186	.0206	.0203	.0210	.0210	.0201	.0201	.0201

Table 34 Arm volume per body weight (Liter/kg) of individual subject in anaerobic group

	Left arm volume per body weight anaerobic group (Liter/kg)													
	Left Pull Pulley							Right Pull Pulley						
	Pre	T1	T2	T3	T4	Pre	T1	T2	T3	T4				
Anaerobic 1	.0213	.0197	.0214	.0214	.0209	.0206	.0209	.0203	.0201	.0222				
Anaerobic 2	.0211	.0205	.0196	.0203	.0194	.0204	.0181	.0200	.0187	.0186				
Anaerobic 3	.0199	.0179	.0201	.0197	.0189	.0185	.0198	.0196	.0194	.0199				
Anaerobic 4	.0232	.0206	.0201	.0195	.0204	.0223	.0200	.0209	.0214	.0225				
Anaerobic 5	.0164	.0178	.0172	.0168	.0167	.0180	.0171	.0175	.0183	.0177				
Anaerobic 6	.0209	.0207	.0213	.0205	.0204	.0207	.0210	.0209	.0199	.0197				
Anaerobic 7	.0176	.0189	.0187	.0186	.0183	.0203	.0173	.0187	.0195	.0201				
Anaerobic 8	.0177	.0180	.0180	.0189	.0176	.0173	.0201	.0186	.0178	.0194				
Anaerobic 9	.0209	.0207	.0214	.0201	.0218	.0206	.0189	.0195	.0206	.0215				
Anaerobic 10	.0179	.0182	.0184	.0183	.0188	.0194	.0193	.0178	.0187	.0189				
Anaerobic 11	.0141	.0126	.0144	.0129	.0134	.0147	.0131	.0142	.0150	.0150				
Anaerobic 12	.0176	.0187	.0184	.0179	.0168	.0172	.0190	.0188	.0175	.0194				
Anaerobic 13	.0136	.0159	.0168	.0146	.0133	.0148	.0147	.0156	.0142	.0143				
Anaerobic 14	.0216	.0208	.0214	.0204	.0207	.0216	.0218	.0215	.0223	.0191				

Table 35 Arm volume per body weight (Liter/kg) of individual subject in anaerobic group

	Left Arm volume per body weight anaerobic group (Liter/kg)													
	VO max test							Wingate test						
	Pre	T1	T2	T3	T4	Pre	T1	T2	T3	T4				
Anaerobic 1	.0204	.0211	.0216	.0209	.0207	.0207	.0208	.0185	.0198	.0203				
Anaerobic 2	.0178	.0176	.0169	.0173	.0173	.0156	.0176	.0118	.0169	.0175				
Anaerobic 3	.0174	.0205	.0201	.0176	.0178	.0191	.0191	.0196	.0198	.0197				
Anaerobic 4	.0169	.0193	.0187	.0188	.0189	.0222	.0214	.0224	.0239	.0218				
Anaerobic 5	.0166	.0123	.0111	.0118	.0130	.0161	.0171	.0174	.0100	.0166				
Anaerobic 6	.0159	.0148	.0136	.0147	.0150	.0186	.0182	.0165	.0165	.0167				
Anaerobic 7	.0139	.0125	.0124	.0133	.0114	.0182	.0187	.0168	.0188	.0184				
Anaerobic 8	.0185	.0180	.0182	.0200	.0182	.0186	.0208	.0209	.0194	.0217				
Anaerobic 9	.0194	.0203	.0210	.0203	.0211	.0205	.0199	.0211	.0205	.0192				
Anaerobic 10	.0213	.0204	.0211	.0195	.0199	.0197	.0211	.0198	.0184	.0186				
Anaerobic 11	.0151	.0155	.0167	.0168	.0188	.0171	.0160	.0179	.0181	.0179				
Anaerobic 12	.0164	.0165	.0193	.0191	.0180	.0180	.0177	.0170	.0177	.0170				
Anaerobic 13	.0175	.0182	.0180	.0190	.0257	.0173	.0166	.0164	.0166	.0167				
Anaerobic 14	.0207	.0201	.0184	.0193	.0206	.0202	.0200	.0197	.0206	.0194				

Table 36 Arm volume per body weight (Liter/kg) of individual subject in anaerobic group

	Right Arm volume per body weight anaerobic group (Liter/kg)												
	VO max test						Wingate test						
	Pre	T1	T2	T3	T4		Pre	T1	T2	T3	T4		
Anaerobic 1	.0212	.0213	.0218	.0195	.0209		.0222	.0217	.0206	.0221	.0210		
Anaerobic 2	.0153	.0180	.0160	.0164	.0168		.0166	.0197	.0149	.0202	.0171		
Anaerobic 3	.0181	.0202	.0198	.0178	.0175		.0172	.0178	.0184	.0195	.0185		
Anaerobic 4	.0153	.0159	.0178	.0180	.0178		.0206	.0183	.0184	.0200	.0190		
Anaerobic 5	.0166	.0103	.0164	.0099	.0117		.0168	.0198	.0205	.0186	.0202		
Anaerobic 6	.0161	.0155	.0154	.0156	.0173		.0182	.0193	.0180	.0182	.0186		
Anaerobic 7	.0143	.0144	.0143	.0134	.0124		.0179	.0175	.0184	.0186	.0179		
Anaerobic 8	.0185	.0189	.0190	.0190	.0182		.0237	.0199	.0213	.0209	.0225		
Anaerobic 9	.0227	.0202	.0216	.0234	.0208		.0212	.0213	.0215	.0213	.0223		
Anaerobic 10	.0216	.0201	.0183	.0208	.0201		.0197	.0193	.0200	.0223	.0200		
Anaerobic 11	.0213	.0186	.0207	.0184	.0191		.0191	.0176	.0181	.0173	.0177		
Anaerobic 12	.0182	.0192	.0205	.0192	.0193		.0186	.0184	.0176	.0200	.0187		
Anaerobic 13	.0177	.0184	.0196	.0201	.0194		.0166	.0172	.0183	.0188	.0189		
Anaerobic 14	.0159	.0178	.0178	.0198	.0176		.0184	.0178	.0171	.0187	.0178		

Table 37 Leg volume per body weight (Liter/kg) of individual subject in anaerobic group

	Left Leg volume per body weight anaerobic group (Liter/kg)													
	VO max test							Wingate test						
	Pre	T1	T2	T3	T4	Pre	T1	T2	T3	T4				
Anaerobic 1	.0463	.0464	.0462	.0439	.0468	.0447	.0484	.0441	.0446	.0452				
Anaerobic 2	.0465	.0450	.0426	.0393	.0395	.0410	.0411	.0410	.0443	.0417				
Anaerobic 3	.0403	.0452	.0464	.0435	.0444	.0399	.0420	.0376	.0390	.0400				
Anaerobic 4	.0365	.0389	.0361	.0411	.0382	.0390	.0419	.0456	.0387	.0392				
Anaerobic 5	.0414	.0344	.0420	.0402	.0390	.0407	.0438	.0423	.0437	.0423				
Anaerobic 6	.0405	.0422	.0432	.0447	.0445	.0431	.0337	.0416	.0430	.0415				
Anaerobic 7	.0430	.0436	.0440	.0461	.0379	.0432	.0448	.0428	.0438	.0439				
Anaerobic 8	.0419	.0430	.0470	.0419	.0443	.0469	.0440	.0440	.0444	.0460				
Anaerobic 9	.0409	.0412	.0407	.0414	.0434	.0461	.0424	.0425	.0428	.0442				
Anaerobic 10	.0397	.0406	.0410	.0423	.0427	.0449	.0476	.0433	.0433	.0458				
Anaerobic 11	.0403	.0406	.0389	.0401	.0393	.0441	.0429	.0435	.0429	.0427				
Anaerobic 12	.0401	.0421	.0419	.0413	.0417	.0419	.0422	.0468	.0440	.0446				
Anaerobic 13	.0448	.0453	.0446	.0449	.0462	.0463	.0420	.0422	.0420	.0468				
Anaerobic 14	.0422	.0403	.0397	.0402	.0416	.0424	.0429	.0419	.0424	.0418				

Table 38 Leg volume per body weight (Liter/kg) of individual subject in anaerobic group

	Right Leg volume per body weight anaerobic group (Liter/kg)													
	VO max test							Wingate test						
	Pre	T1	T2	T3	T4	Pre	T1	T2	T3	T4				
Anaerobic 1	.0444	.0448	.0471	.0464	.0443	.0439	.0442	.0431	.0436	.0433				
Anaerobic 2	.0403	.0387	.0427	.0414	.0403	.0422	.0424	.0429	.0430	.0427				
Anaerobic 3	.0444	.0438	.0425	.0440	.0408	.0402	.0398	.0386	.0386	.0397				
Anaerobic 4	.0388	.0383	.0406	.0394	.0391	.0392	.0385	.0434	.0398	.0441				
Anaerobic 5	.0409	.0451	.0441	.0447	.0428	.0406	.0442	.0437	.0450	.0412				
Anaerobic 6	.0421	.0438	.0424	.0413	.0378	.0354	.0445	.0427	.0440	.0466				
Anaerobic 7	.0428	.0447	.0416	.0393	.0372	.0426	.0434	.0438	.0430	.0418				
Anaerobic 8	.0471	.0429	.0458	.0477	.0485	.0479	.0475	.0474	.0471	.0473				
Anaerobic 9	.0448	.0421	.0411	.0442	.0451	.0453	.0463	.0435	.0467	.0486				
Anaerobic 10	.0426	.0421	.0434	.0398	.0412	.0424	.0466	.0409	.0432	.0476				
Anaerobic 11	.0430	.0361	.0439	.0433	.0437	.0409	.0422	.0405	.0434	.0420				
Anaerobic 12	.0416	.0426	.0406	.0412	.0418	.0428	.0389	.0432	.0429	.0436				
Anaerobic 13	.0460	.0495	.0479	.0475	.0477	.0483	.0457	.0481	.0470	.0482				
Anaerobic 14	.0425	.0415	.0395	.0419	.0403	.0428	.0435	.0421	.0418	.0400				

Table 39 Heart rate of individual subject in control group

	Heart rate control group (bpm)														
	Left Inflated Blood Pressure Cuff							Right Inflated Blood Pressure Cuff							
	Pre	T1	T2	T3	T4	Pre	T1	T2	T3	T4	Pre	T1	T2	T3	T4
Control 1	83	75	75	91	72	72	79	73	71	72	72	79	73	71	76
Control 2	84	84	85	75	71	70	78	76	70	75	70	78	76	70	75
Control 3	70	69	72	78	68	69	71	72	68	66	69	71	72	63	66
Control 4	81	85	81	76	72	71	79	77	72	75	71	79	77	72	75
Control 5	84	76	76	92	73	73	80	74	73	77	73	80	74	72	77
Control 6	84	85	85	77	73	71	80	78	73	77	71	80	78	73	77
Control 7	83	76	74	90	71	71	78	72	71	75	71	78	72	70	75
Control 8	80	73	73	90	72	72	78	73	72	74	72	78	73	71	74
Control 9	85	85	85	76	72	70	79	78	72	76	70	79	78	72	76
Control 10	71	70	73	79	69	70	71	73	69	67	70	71	73	64	67
Control 11	69	68	71	77	68	68	70	71	68	65	68	70	71	63	65
Control 12	71	71	72	78	68	68	71	72	68	67	68	71	72	64	67

Table 40 Heart rate of individual subject in control group

	Heart rate control group (bpm)														
	Left Pull Pulley							Right Pull Pulley							
	Pre	T1	T2	T3	T4	Pre	T1	T2	T3	T4	Pre	T1	T2	T3	T4
Control 1	82	72	85	73	81	86	85	84	76	102	86	85	84	76	102
Control 2	73	66	70	77	74	74	69	71	65	75	74	69	71	65	75
Control 3	72	73	68	70	82	71	72	66	72	72	71	72	66	72	72
Control 4	75	68	71	78	75	73	68	71	67	74	73	68	71	67	74
Control 5	83	73	86	74	82	87	86	85	77	103	87	86	85	77	103
Control 6	74	67	70	76	76	73	69	70	67	75	73	69	70	67	75
Control 7	81	71	84	73	80	84	84	83	75	101	84	84	83	75	101
Control 8	79	69	82	73	80	86	85	84	75	100	86	85	84	75	100
Control 9	75	67	71	77	75	75	70	71	66	76	75	70	71	66	76
Control 10	73	74	69	71	83	71	73	67	72	71	71	73	67	72	71
Control 11	71	72	67	69	80	70	71	65	71	71	70	71	65	71	71
Control 12	72	74	68	70	80	70	72	66	73	72	70	72	66	73	72

Table 41 Heart rate of individual subject in control group

	Heart rate control group (bpm)												
	VO max test						Wingate test						
	Pre	T1	T2	T3	T4	Pre	T1	T2	T3	T4			
Control 1	81	175	119	104	100	100	148	129	100	94			
Control 2	78	138	90	85	78	93	138	107	93	78			
Control 3	94	156	116	99	93	100	171	135	89	93			
Control 4	75	145	90	87	82	90	142	118	103	80			
Control 5	82	174	120	105	100	98	150	130	101	95			
Control 6	77	145	91	85	79	93	147	108	93	79			
Control 7	80	173	118	103	98	97	142	127	98	93			
Control 8	78	170	121	102	100	95	144	117	98	93			
Control 9	79	140	92	86	80	94	140	109	94	79			
Control 10	93	155	115	98	93	100	170	134	88	94			
Control 11	93	155	115	98	92	98	170	133	88	92			
Control 12	90	150	113	97	93	97	160	128	90	93			

Table 42 Heart rate of individual subject in aerobic group

	Heart rate aerobic group (bpm)														
	Left Inflated Blood Pressure Cuff							Right Inflated Blood Pressure Cuff							
	Pre	T1	T2	T3	T4	Pre	T1	T2	T3	T4	Pre	T1	T2	T3	T4
Aerobic 1	85	93	91	88	88	93	97	93	88	88	93	97	93	86	81
Aerobic 2	70	63	63	63	65	65	70	70	67	67	65	70	70	69	67
Aerobic 3	84	62	62	62	62	67	67	67	62	62	67	67	67	67	74
Aerobic 4	74	78	76	79	78	72	80	75	79	78	72	80	75	77	77
Aerobic 5	72	76	75	80	79	70	81	75	80	79	70	81	75	76	78
Aerobic 6	74	76	76	80	79	72	80	76	80	79	72	80	76	77	78
Aerobic 7	70	78	78	80	79	72	85	76	80	79	72	85	76	77	78
Aerobic 8	83	61	61	61	60	68	68	70	61	60	68	68	70	70	73
Aerobic 9	87	95	93	90	90	95	100	94	90	90	95	100	94	87	83
Aerobic 10	73	75	75	79	78	71	79	75	79	78	71	79	75	76	77
Aerobic 11	85	63	63	62	62	68	68	68	62	62	68	68	68	67	75
Aerobic 12	75	62	61	60	63	67	67	68	60	63	67	67	68	68	71
Aerobic 13	86	94	92	89	89	94	98	93	89	89	94	98	93	86	82
Aerobic 14	75	77	77	81	80	73	81	77	81	80	73	81	77	78	79

Table 43 Heart rate of individual subject in aerobic group

	Heart rate aerobic group (bpm)														
	Left Pull Pulley							Right Pull Pulley							
	Pre	T1	T2	T3	T4	Pre	T1	T2	T3	T4	Pre	T1	T2	T3	T4
Aerobic 1	87	89	74	86	76	74	69	69	68	66	74	69	69	68	66
Aerobic 2	65	78	77	72	63	62	67	69	80	62	67	69	80	62	
Aerobic 3	62	76	76	71	60	60	66	69	80	60	66	69	80	60	
Aerobic 4	87	72	80	74	75	90	77	72	81	90	77	72	81	68	
Aerobic 5	88	72	80	73	72	88	78	70	80	88	78	70	80	66	
Aerobic 6	89	72	82	72	75	94	76	72	83	94	76	72	83	68	
Aerobic 7	85	72	82	72	71	90	76	72	80	90	76	72	80	65	
Aerobic 8	61	75	75	70	60	59	65	68	79	59	65	68	79	59	
Aerobic 9	89	92	76	87	77	76	71	71	70	76	71	71	70	68	
Aerobic 10	88	71	81	71	74	93	75	71	82	93	75	71	82	67	
Aerobic 11	63	77	77	72	61	61	67	70	81	61	67	70	81	61	
Aerobic 12	62	76	77	70	62	60	66	68	80	60	66	68	80	62	
Aerobic 13	88	90	75	87	77	75	70	70	69	75	70	70	69	67	
Aerobic 14	90	73	83	73	70	94	77	73	84	94	77	73	84	69	

Table 44 Heart rate of individual subject in aerobic group

	Heart rate aerobic group (bpm)														
	VO max test							Wingate test							
	Pre	T1	T2	T3	T4	Pre	T1	T2	T3	T4	Pre	T1	T2	T3	T4
Aerobic 1	81	93	75	75	76	112	173	123	118	105	112	173	123	118	105
Aerobic 2	74	115	89	87	76	10	183	107	94	90	10	183	107	94	90
Aerobic 3	74	106	88	85	75	104	191	102	97	92	104	191	102	97	92
Aerobic 4	86	125	97	96	85	85	178	120	93	82	85	178	120	93	82
Aerobic 5	86	143	110	95	88	87	170	130	95	80	87	170	130	95	80
Aerobic 6	86	140	106	96	87	88	141	120	97	86	88	141	120	97	86
Aerobic 7	81	135	103	92	84	85	148	120	95	82	85	148	120	95	82
Aerobic 8	73	105	87	84	74	103	190	100	96	91	103	190	100	96	91
Aerobic 9	83	95	77	77	78	115	175	125	120	108	115	175	125	120	108
Aerobic 10	85	138	105	95	86	87	140	118	96	85	87	140	118	96	85
Aerobic 11	75	107	89	86	76	105	192	103	98	93	105	192	103	98	93
Aerobic 12	73	109	88	84	71	98	187	100	97	92	98	187	100	97	92
Aerobic 13	82	94	76	76	77	113	174	125	119	107	113	174	125	119	107
Aerobic 14	88	143	108	97	88	89	145	123	98	87	89	145	123	98	87

Table 45 Heart rate of individual subject in anaerobic group

	Heart rate anaerobic group (bpm)													
	Left Inflated Blood Pressure Cuff							Right Inflated Blood Pressure Cuff						
	Pre	T1	T2	T3	T4	Pre	T1	T2	T3	T4	Pre	T1	T2	T3
Anaerobic 1	83	87	76	78	82	81	81	75	77	72	81	75	77	72
Anaerobic 2	78	87	86	85	77	77	80	86	77	77	80	86	77	77
Anaerobic 3	81	80	71	78	72	87	85	73	77	77	85	73	77	85
Anaerobic 4	76	78	71	75	70	80	84	74	81	81	84	74	81	81
Anaerobic 5	80	79	68	79	71	86	83	73	76	80	83	73	76	80
Anaerobic 6	82	86	70	77	81	80	80	74	76	71	80	74	76	71
Anaerobic 7	81	78	69	80	74	84	84	77	77	77	84	77	77	77
Anaerobic 8	78	80	77	80	71	80	82	89	78	79	80	89	78	79
Anaerobic 9	81	80	69	80	72	87	84	74	77	81	84	74	77	81
Anaerobic 10	78	83	86	85	74	77	83	86	75	75	77	86	77	75
Anaerobic 11	84	88	77	78	83	82	82	75	78	73	82	75	78	73
Anaerobic 12	80	90	87	83	83	77	81	89	80	80	81	89	80	80
Anaerobic 13	82	81	70	81	74	88	85	75	78	82	85	75	78	82
Anaerobic 14	78	87	85	85	75	79	82	86	77	76	79	86	77	76

Table 46 Heart rate of individual subject in anaerobic group

	Heart rate anaerobic group (bpm)														
	Left Pull Pulley							Right Pull Pulley							
	Pre	T1	T2	T3	T4	Pre	T1	T2	T3	T4	Pre	T1	T2	T3	T4
Anaerobic 1	84	72	78	75	86	87	75	82	82	86	87	75	82	82	86
Anaerobic 2	72	85	75	72	69	91	69	77	67	70	91	69	77	67	62
Anaerobic 3	71	87	80	75	70	79	83	77	73	70	79	83	77	73	80
Anaerobic 4	70	83	75	72	67	90	69	77	66	67	90	69	77	66	63
Anaerobic 5	92	76	78	73	75	78	83	76	72	75	78	83	76	72	79
Anaerobic 6	83	71	77	74	85	86	74	81	81	85	86	74	81	81	85
Anaerobic 7	92	80	79	74	77	91	70	76	66	77	91	70	76	66	88
Anaerobic 8	72	85	75	72	69	78	69	77	65	69	78	69	77	65	60
Anaerobic 9	93	77	79	74	76	79	84	77	73	76	79	84	77	73	80
Anaerobic 10	72	86	76	71	69	80	69	80	67	69	80	69	80	67	62
Anaerobic 11	73	86	76	73	70	90	70	78	68	70	90	70	78	68	62
Anaerobic 12	93	79	81	76	78	77	83	71	68	78	77	83	71	68	75
Anaerobic 13	94	78	81	76	77	80	85	77	74	77	80	85	77	74	81
Anaerobic 14	91	77	79	72	74	79	84	75	70	74	79	84	75	70	77

Table 47 Heart rate of individual subject in anaerobic group

	Heart rate anaerobic group (bpm)														
	VO max test							Wingate test							
	Pre	T1	T2	T3	T4	Pre	T1	T2	T3	T4	Pre	T1	T2	T3	T4
Anaerobic 1	87	152	118	113	113	112	177	139	132	120	112	177	139	132	120
Anaerobic 2	88	144	87	91	78	97	178	130	107	94	97	178	130	107	94
Anaerobic 3	80	150	87	97	78	81	165	138	125	115	81	165	138	125	115
Anaerobic 4	82	146	109	90	81	83	160	131	112	84	83	160	131	112	84
Anaerobic 5	79	173	115	90	96	94	163	141	134	115	94	163	141	134	115
Anaerobic 6	86	151	117	112	112	110	175	137	130	120	110	175	137	130	120
Anaerobic 7	88	144	86	90	76	97	160	128	109	87	97	160	128	109	87
Anaerobic 8	84	148	84	78	76	95	178	131	110	92	95	178	131	110	92
Anaerobic 9	80	149	115	91	96	94	165	143	135	117	94	165	143	135	117
Anaerobic 10	84	150	112	90	93	95	170	132	127	108	95	170	132	127	108
Anaerobic 11	85	151	87	90	78	98	170	127	105	90	98	170	127	105	90
Anaerobic 12	82	149	112	90	95	94	173	130	104	92	94	173	130	104	92
Anaerobic 13	81	150	117	91	95	93	167	145	135	116	93	167	145	135	116
Anaerobic 14	81	152	115	91	94	90	167	132	127	110	90	167	132	127	110

APPENDIX C

หนังสือยินยอมให้ทำการวิจัยโดยรับการบอกกล่าวและเต็มใจ (Informed consent form)

ชื่อโครงการ “ ผลของการออกกำลังกายระยะยาวต่อการเปลี่ยนแปลงของเส้นเลือด จากการใช้กล้ามเนื้อใน
ระยะสั้น” (Alteration of vasomotor responses of arms and legs by
exercise stimulation in aerobic and anaerobic athletes)

วันที่ให้คำยินยอม วันที่..... เดือน..... พ.ศ.

ก่อนที่จะลงนามในใบยินยอมทำการวิจัยนี้ ข้าพเจ้าได้รับการอธิบายจากผู้วิจัยถึงวัตถุประสงค์ของการวิจัย
วิธีการวิจัย อันตราย หรืออาการที่อาจเกิดขึ้นจากการวิจัย รวมถึงประโยชน์ที่จะเกิดขึ้นจากการวิจัยอย่างละเอียด
และมีความเข้าใจดีแล้ว

ผู้วิจัยรับรองว่าจะตอบคำถามต่างๆที่ข้าพเจ้าสงสัยด้วยความเต็มใจ ไม่ปิดบังซ่อนเร้น จนข้าพเจ้า

ข้าพเจ้าเข้าร่วมการวิจัยโดยสมัครใจและมีสิทธิที่จะยกเลิกการเข้าร่วมการวิจัยนี้เมื่อใดก็ได้

ผู้วิจัยรับรองว่าจะเก็บข้อมูลเฉพาะตัวข้าพเจ้าเป็นความลับ และจะเปิดเผยได้เฉพาะในรูปแบบที่เป็นการสรุป
ผลการวิจัย กรณีเปิดเผยข้อมูลเกี่ยวกับตัวข้าพเจ้าต่อหน่วยงานต่างๆที่เกี่ยวข้อง กระทำได้เฉพาะในกรณีจำเป็นด้วย
เหตุผลทางวิชาการเท่านั้น

ผู้วิจัยรับรองว่าหากเกิดอันตรายใดๆอันเนื่องมาจากการวิจัยดังกล่าว ข้าพเจ้าจะได้รับการรักษาพยาบาลโดยไม่
คิดมูลค่าตามมาตรฐานวิชาชีพ และจะได้รับการชดเชยรายได้ที่สูงเสียไประหว่างการรักษาพยาบาลดังกล่าว
ตลอดจนเงินทดแทนความพิการที่อาจเกิดขึ้น

ผู้วิจัยรับรองว่าหากมีข้อมูลเพิ่มเติมที่ส่งผลกระทบต่อกรวิจัย ข้าพเจ้าจะได้รับการแจ้งให้ทราบโดยไม่ปิดบัง
ซ่อนเร้น

ข้าพเจ้าได้อ่านข้อความข้างต้น และมีความเข้าใจทุกประการและได้ลงนามในใบยินยอมนี้ด้วยความเต็มใจ

ลงชื่อ.....(ผู้ยินยอม)

ลงชื่อ.....(พยาน)

ลงชื่อ.....(พยาน)

อังศุมลลิน ภูมิชัย

ผู้วิจัย

APPENDIX D
Table 48 โปรแกรมการฝึกเพื่อพัฒนาความอดทน AEROBIC และเพื่อพัฒนาความเร็วและความแข็งแรง ANAEROBIC

วัน	โปรแกรมการฝึก AEROBIC		โปรแกรมการฝึก ANAEROBIC	
	การฝึก	เวลา	การฝึก	เวลา
จันทร์	<ul style="list-style-type: none"> - อบอุ่นร่างกาย โดยการจ็อกกิ้ง เสร็จแล้วยืดกล้ามเนื้อ - ตารางเก้าช่อง (Nine Square) - คลายอุ่น 	<ul style="list-style-type: none"> - 5 - 8 นาที - 20 - 30 นาที - 5 - 8 นาที 	<ul style="list-style-type: none"> - อบอุ่นร่างกาย เสร็จแล้วยืดกล้ามเนื้อ - Weight Training ในท่า Leg Curl & Leg Extension Arm Curl - คลายอุ่น 	<ul style="list-style-type: none"> - 5 - 8 นาที - ความหนักระดับ 70 - 80% ของ 1RM 10 ครั้ง / เซต 3 เซต / วัน แต่ละเซตพัก 3 นาที - 5 - 8 นาที
พุธ	<ul style="list-style-type: none"> - เต้นแอโรบิค ให้ครบขั้นตอน - คลายอุ่น 	<ul style="list-style-type: none"> - 45 - 50 นาที - 5 - 8 นาที 	<ul style="list-style-type: none"> - อบอุ่นร่างกาย เสร็จแล้วยืดกล้ามเนื้อ - วิ่งระยะทาง 50 เมตร (เต็มที่) 10 เที้ยว - คลายอุ่น 	<ul style="list-style-type: none"> - 10 นาที - แต่ละเที้ยวพัก 3 นาที - 5 - 8 นาที
ศุกร์	<ul style="list-style-type: none"> - อบอุ่นร่างกาย โดยการจ็อกกิ้ง เสร็จแล้วยืดกล้ามเนื้อ - วิ่งจ็อกกิ้ง ระยะทาง 4 Km. 	<ul style="list-style-type: none"> - 5 - 8 นาที - 20 นาทีขึ้นไป 	<ul style="list-style-type: none"> - อบอุ่นร่างกาย เสร็จแล้วยืดกล้ามเนื้อ - Weight Training ในท่า Leg Curl & Leg Extension Arm Curl - คลายอุ่น 	<ul style="list-style-type: none"> - 5 - 8 นาที - ความหนักระดับ 70 - 80% ของ 1RM 10 ครั้ง / เซต 3 เซต / วัน แต่ละเซตพัก 3 นาที - 5 - 8 นาที

BIOGRAPHY

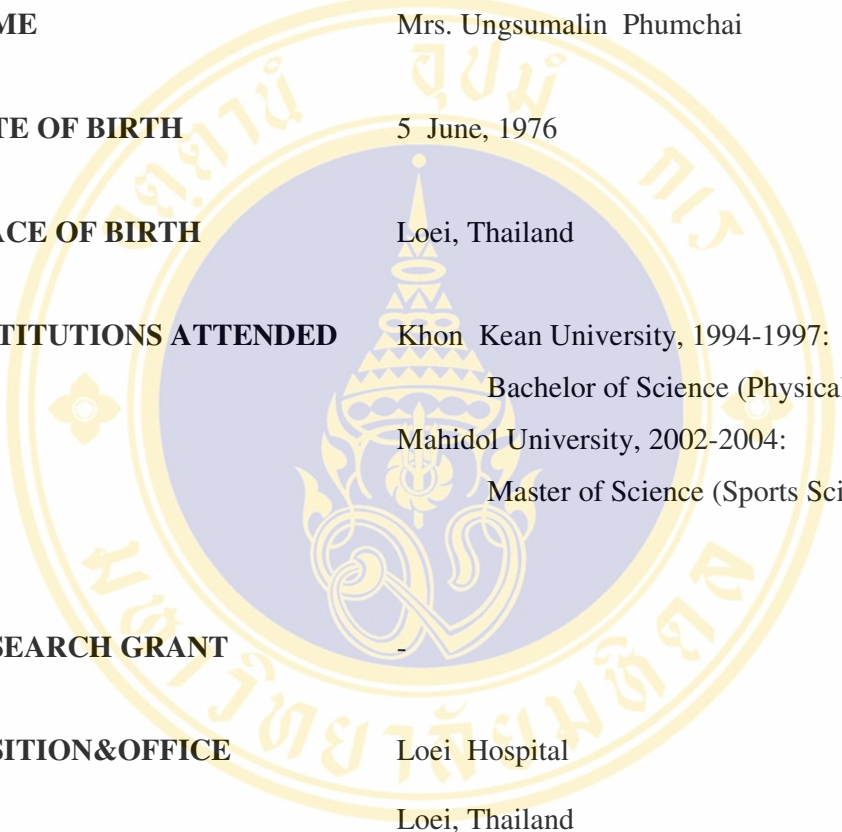

NAME	Mrs. Ungsumalin Phumchai
DATE OF BIRTH	5 June, 1976
PLACE OF BIRTH	Loei, Thailand
INSTITUTIONS ATTENDED	Khon Kean University, 1994-1997: Bachelor of Science (Physical Therapy) Mahidol University, 2002-2004: Master of Science (Sports Science)
RESEARCH GRANT	-
POSITION&OFFICE	Loei Hospital Loei, Thailand
HOME ADDRESS	91/3 Maliwun road ,Moo 9, Tumbon Naaun, Aumper Mueang ,Loei, 42000