

**IMPROVEMENT AND DEVELOPMENT FOR WIRELESS LAN
IN THE IN-PATIENT DEPARTMENT (IPD)
OF VIBHAVADI GENERAL HOSPITAL**



SAKOL SUMTRAGOOL

**A THEMATIC PAPER SUBMITTED IN PARTIAL
FULFILLMENT OF THE REQUIREMENTS FOR
THE DEGREE OF MASTER OF SCIENCE
(TECHNOLOGY OF INFORMATION SYSTEM MANAGEMENT)
FACULTY OF GRADUATE STUDIES
MAHIDOL UNIVERSITY**

2014

COPYRIGHT OF MAHIDOL UNIVERSITY

Thematic Paper
entitled
**IMPROVEMENT AND DEVELOPMENT FOR WIRELESS LAN
IN THE IN-PATIENT DEPARTMENT (IPD)
OF VIBHAVADI GENERAL HOSPITAL**

Sakol Sumtragool

Mr.Sakol Sumtragool
Candidate

Adisorn Leelasantitham

Asst. Prof Adisorn Leelasantitham,
Ph.D. (Electrical Engineering)
Major advisor

[Signature]

Asst. Prof Supaporn Kiattisin,
Ph.D. (Electrical and Computer
Engineering)
Co-advisor

[Signature]

Patcharee Lertrit

Prof. Patcharee Lertrit,
M.D., Ph.D. (Biochemistry)
Dean
Faculty of Graduate Studies
Mahidol University

Asst. Prof Supaporn Kiattisin,
Ph.D. (Electrical and Computer
Engineering)
Program Director
Master of Science Program in
Technology of Information System
Management
Faculty of Engineering
Mahidol University

Thematic Paper
entitled
**IMPROVEMENT AND DEVELOPMENT FOR WIRELESS LAN
IN THE IN-PATIENT DEPARTMENT (IPD)
OF VIBHAVADI GENERAL HOSPITAL**

was submitted to the Faculty of Graduate Studies, Mahidol University
for the degree of Master of Science
(Technology of Information System Management)

on
December 20, 2014

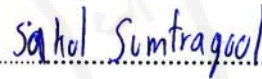

Mr. Sakol Sumtragool
Candidate



Lect. Sotarath Thammaboosadee,
Ph.D. (Information Technology)
Chair

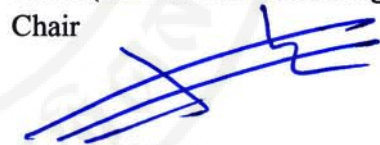

Asst. Prof. Supaporn Kiattisin,
Ph.D. (Electrical and Computer
Engineering)
Member



Asst. Prof. Adisorn Leelasantitham,
Ph.D. (Electrical Engineering)
Member

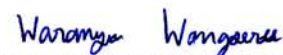

Asst. Prof. Waranyu Wongseree,
Ph.D. (Electrical Engineering)
Member



Lect. Worawit Israngkul,
M.S. (Technical Management)
Dean
Faculty of Engineering
Mahidol University

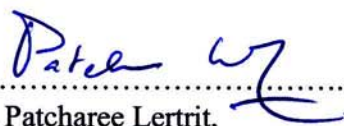

Prof. Patcharee Lertrit,
M.D., Ph.D. (Biochemistry)
Dean
Faculty of Graduate Studies
Mahidol University

ACKNOWLEDGEMENTS

Completion of thesis was successful with support from my major Asst. Prof. Dr. Adisorn Leelasantitham's guidance, valuable advice, and knowledge. I would like to thank my co-advisors, Asst. Prof. Dr. Supaporn Kiattisin and Asst. Prof. Dr. Waranyu Wongseree for their special attentiveness, always listening, and giving invaluable suggestions. I wish to express my most sincere thanks for all your kindness.

Special thanks to Lect. Dr. Sotarath Thammaboosadee for the graduate program valuable encouragement, guidance, supervision and suggestions throughout.

Special thanks are given to all the lecturers and staffs of the Technology of Information System Management Program, Faculty of Engineering, Mahidol University for their services and supports. I would also like to thank all of my friends for their helps and encouragements.

Lastly, I would like to thank my family for encouragement with love. They have inspired me to overcome the obstacles of the thematic research.

Sakol Sumtragool

**IMPROVEMENT AND DEVELOPMENT FOR WIRELESS LAN IN THE
IN-PATIENT DEPARTMENT (IPD) OF VIBHAVADI GENERAL HOSPITAL**

SAKOL SUMTRAGOOL 5537224 EGTI/M

M.Sc. (TECHNOLOGY OF INFORMATION SYSTEM MANAGEMENT)

**THEMATIC PAPER ADVISORY COMMITTEE: ADISORN LEELASANTITHAM,
Ph.D., SUPAPORN KIATTISIN, Ph.D., WARANYU WONGSEREE, Ph.D.**

ABSTRACT

Currently, WiFi service is often not available in patient rooms at Vibhavadi General Hospital. A part of the problem is that the user cannot use the Internet because of the presence of a thick cement wall which absorbs and reduces the WiFi signal range.

A careful examination of the physical characteristics from the patient rooms shows that there are unique features: the room is L-shaped, which degrades the linear WiFi signal and the WiFi signal is blocked by concrete walls. The result of this combination is signal attenuation so that the users cannot access the network.

To explore the intensity of the WiFi signal attenuation within the patient rooms, the InSSIDer and TamoGraph Site Survey for checking both dead spots and WiFi signal strength are used to compare the values obtained from different areas in the rooms. After the WiFi dead spots were identified, then additional access points were added. Using the Wireless Extended Service Set application, the access points were located in consideration of their signal overlap. After installation and configuration of the equipment, the values are rechecked again for comparison.

The results of the site survey shown the WiFi signal attenuation in the patient room before the service expansion of -50dB is not effective. At this level, WiFi is not effective. After installing the additional access points, the signal attenuation is reduced to -40dB, which is effective for wireless devices in the patient rooms, satisfying the customers and patients at the hospital-

**KEY WORDS: WIRELESS LAN / SATISFACTION OF PATIENTS /
THE WIRELESS LAN SOLUTION / ROAMING**

ปรับปรุงและพัฒนาสำหรับเครือข่ายไร้สายในแผนกผู้ป่วยในของโรงพยาบาลวิภาวดี

IMPROVEMENT AND DEVELOPMENT FOR WIRELESS LAN IN THE
IN-PATIENT DEPARTMENT (IPD) OF VIBHAVADI GENERAL HOSPITAL

สกล สุ่มตระกูล 5537224 EGTI/M

วท.ม. (เทคโนโลยีการจัดการระบบสารสนเทศ)

คณะกรรมการที่ปรึกษาสารนิพนธ์ : อติสร ลีลาสันติธรรม, Ph.D., สุภาภรณ์ เกียรติสิน, Ph.D.,
วรัญญู วงษ์เสรี, Ph.D.

บทคัดย่อ

ในปัจจุบันการให้บริการสัญญาณ WiFi ในพื้นที่ห้องพักรักษาตัวใน ยังไม่ครอบคลุมพื้นที่ให้บริการในห้องพักรักษาตัว ส่วนหนึ่งไม่สามารถใช้บริการ Internet ได้ เนื่องจากปัจจัยของห้อง ซึ่งมีผนังซีเมนต์ เป็นตัวดูดซับสัญญาณ WiFi จึงทำให้ สัญญาณ WiFi มีกำลังที่อ่อนลง จึงเป็นปัจจัยทำให้ผู้มาใช้บริการภายในห้อง ไม่สามารถใช้บริการ WiFi ได้

จากการตรวจสอบลักษณะทางกายภาพของห้องพักรักษาตัวใน เป็นลักษณะของห้องพักที่แบ่งออกเป็นห้องเรียงกัน ลักษณะรูปตัว L และประกอบด้วยผนังซีเมนต์ ใช้แบ่งห้องต่าง ๆ นั้นทำให้สัญญาณ WiFi นั้นถูกดูดซับสัญญาณจนทำให้ห้องส่วนหนึ่งไม่สามารถรับสัญญาณ WiFi ได้

ดังนั้นจึงดำเนินการสำรวจความเข้มของสัญญาณ WiFi เพื่อตรวจหาความแรงสัญญาณภายในห้องพักรักษาตัวใน โดยใช้โปรแกรม InSSIDer และ TamoGraph site survey เพื่อหาจุดอ่อนของสัญญาณ และความเข้มของสัญญาณ WiFi โดยใช้โปรแกรมทั้ง 2 Program นี้ตรวจสอบและนำมาเปรียบเทียบค่าที่ได้ ในจุดต่าง ๆ ของห้องพักรักษาตัวใน หลังจากนั้นก็ทำการขยายสัญญาณ โดยการเพิ่ม Access Point เพิ่มเข้าไปในพื้นที่จุดอ่อนสัญญาณ และกำหนดให้รัศมีการแพร่กระจายคลื่นของ Access Point ที่ติดตั้งเพิ่มมีส่วนคาบเกี่ยวกันและนำคุณสมบัติแบบ Infrastructure มาประยุกต์ใช้ ที่เรียกว่า Wireless Extended Service Set

จากการทดลองพบว่า ผลการการทำ Site Survey ก่อนขยายพื้นที่บริการ มีค่า น้อยกว่า -50 dB ซึ่งเป็นตัวเลขที่ อุปกรณ์สื่อสารไม่สามารถใช้สัญญาณ WiFi ได้ และเมื่อหลังจาก Roaming แล้วโดยการนำ Infrastructure มาใช้แก้ปัญหาพบว่า มีค่า -50 dB ถึง -40 dB จึงทำให้ผู้มาใช้บริการมีความพึงพอใจในการใช้สัญญาณ WiFi

CONTENTS

	Page
ACKNOWLEDGEMENTS	iii
ABSTRACT (ENGLISH)	iv
ABSTRACT (THAI)	v
LIST OF TABLES	viii
LIST OF FIGURES	ix
CHAPTER I INTRODUCTION	1
1.1 Introduction	1
1.2 Objective of study	2
1.3 Scope of study	3
1.4 Expected result of study	3
1.5 Outline summary	3
CHAPTER II LITERATURE REVIEW AND THEORY	4
2.1 Wireless LAN History	4
2.2 Wireless standard 802.11	5
2.3 Amplitude	6
2.4 Obstacles of wireless LAN signal strength	6
2.5 Wavelength and bandwidth intervals of wireless LAN	7
2.6 Throughput of non-complying wireless systems	7
2.7 Throughput distance of wireless LAN	9
2.8 Service area analysis	10
2.9 Related Researches	11

CONTENTS (cont.)

	Page
CHAPTER III PROPOSED MODELS	13
3.1 Hospital applications	13
3.2 Wireless LAN survey	13
3.3 Current WiFi system	13
3.4 Determining signal strength between the sender and receiver (Link Margin)	16
3.4.1 Maximum distance calculation	17
3.5 Expansion of the wireless LAN network	19
3.6 Roaming method	19
3.7 Upgrading the access point with the high gain antenna	19
3.8 Adding the WiFi signal booster	20
3.9 Adding the wireless repeater	20
3.10 Extended Service Set (ESS)	21
3.11 Improvement procedure	22
3.12 The proposed WiFi system	23
3.13 Access point location determination	25
CHAPTER IV SIMULATION RESULTS AND DISCUSSION	28
4.1 Wireless LAN service expansion.	28
CHAPTER V CONCLUSION AND FUTURE WORK	30
5.1 Conclusion	30
5.2 Further work	30
REFERENCES	31
APPENDIX	32
BIOGRAPHY	34

LIST OF TABLES

Table	Page
2.1 Characteristics of wireless network technology	6
3.1 Connectivity strength (link margin)	17
3.2 The factor variables for in calculation of the maximum distance.	18

LIST OF FIGURES

Figure	Page
1.1 Wireless Signal strength value of each ward in hospital	2
2.1 Types of Wireless LAN on 802.11 Standards	5
2.2 Amplitude and wave length of waveform	6
2.3 The operation of Wireless LAN protocol on Carrier Sense Multiple Access with Collision Detection (CSMA/CD)	8
2.4 The scope of service area networks, wireless LAN standard IEEE 802.11a, b and g	9
2.5 Diagram of the inpatient accommodations.	10
2.6 Wireless network monitoring program of InSSIDer	11
3.1 Diagram of Access Point positioning on patient's ward	14
3.2 signal strength of the Access Point (AP) at a distance of 1 meter far away from AP	14
3.3 Signal strength at a distance of 8 meters	15
3.4 signal strength behind a wall	15
3.5 The signal strength of the patient's bed	16
3.6 Structure and mechanism of wireless LAN networks	20
3.7 Basic Service Set Infrastructure (BSSI)	21
3.8 The Extended Service Set (ESS) on Wireless LAN network	22
3.9 ARUBA AP-105	23
3.10 Diagram of the installed access point on the 12A-th floor of inpatient, Vibhavadi hospital	25
3.11 The signal strength under the Access Point	26
3.12 Signal strength at a distance of 8 meters	26
3.13 The signal strength in the room behind the door	27
3.14 The signal strength on the patient's bed	27
4.1 Wireless LAN with roaming system	28

LIST OF FIGURES (cont.)

Figure		Page
4.2	The comparison of signal strength results between old system with connection-oriented communication and the purpose system with roaming method	29



CHAPTER I

INTRODUCTION

1.1 Introduction

The key of success for healthcare is the service. A hospital is a healthcare provider comprised of doctors, nurses, staffs, and patients. Nevertheless, healthcare service is not only the function of hospital. Other services include the communication technology especially for the internet. Therefore, hospitals should provide and support online communication through laptops, tablets, smart phones via wireless LAN for the convenience of patients and service receivers.

Internet service in the hospital is also available for all eleven floors except the inpatient's room. Internet is not available on the 12A-th floor due to the situation under the renovation. Moreover, the internet service in the inpatient's room is also not available due to the blocking of cement walls. An initiative solution to improve the wireless access in the inpatient's room resulted in a wireless signal detection test for all eleven floors of the inpatient room. The results can be shown in Figure 1.1.

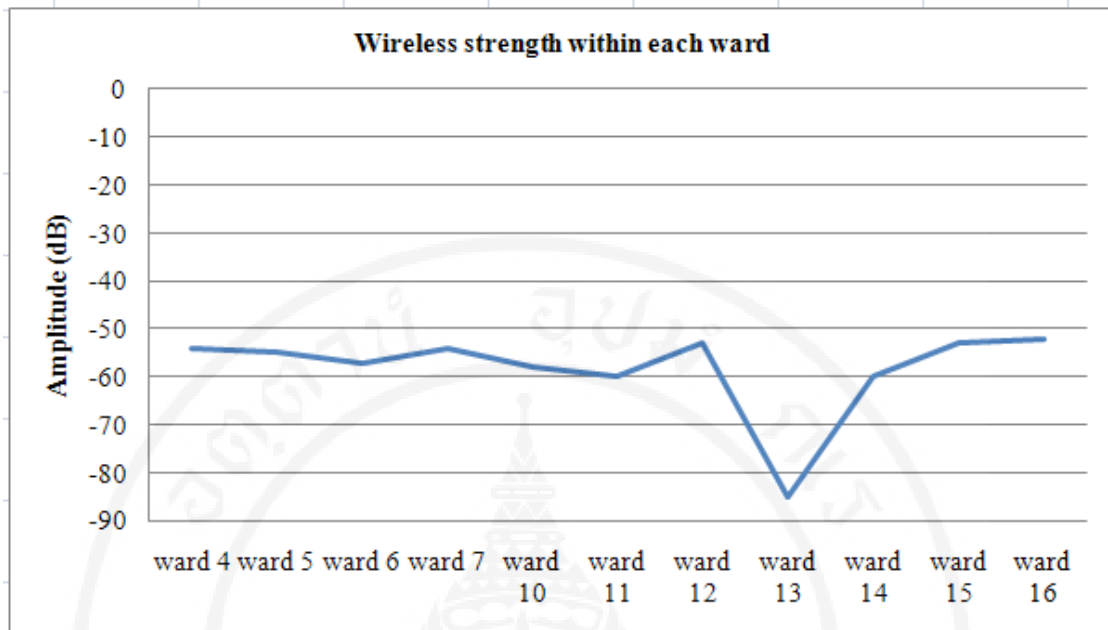

Figure 1.1 Wireless signal strength value of each ward in hospital.

The figure above shows that wireless signal strength differs between wards due to the blocking of cement walls. It is found that wireless signal in ward 12A is as low as -85 dB which causes patients within that ward to not have internet access. This wireless detection test proves that wireless access in the hospital should be improve its wireless equipment especially in 12A-th ward.

1.2 Objective of study

1.2.1 To study the characteristics of wireless equipment to be installed in the hospital.

1.2.2 To study how wireless equipment spreads wireless signal.

1.2.3 To study wireless signal blind spots.

1.2.4 To study the dispersion of wireless signal from two simultaneous sources to solve blind spot issues.

1.2.5 To study the deterioration of wireless signal from obstacles, distance and absorbs.

1.2.6 To determine the optimal location to provide wireless service such that wireless signal can be received throughout the hospital

1.2.7 To study the expansion of wireless LAN service.

1.3 Scope of study

This report serves as a preliminary study of wireless service within Vibhavadi Hospital by integrating wireless receptivity issues and solutions such that the hospital can provide an effective wireless service guaranteeing patient's satisfaction.

1.4 Expected results of study

1.5.1 Specific characteristics of wireless service can be determined.

1.5.2 Wireless equipment would be use the effectively.

1.5.3 Wireless signal can be accessed throughout the hospital.

1.5.4 Customers' complaints would be decreased.

1.5.5 Customers' satisfaction would be improved.

1.5 Outline summary.

Our research is organized as follows: Chapter 2 reviews the papers giving the idea related to our research for WiFi development of Vibhavadi Hospital. Chapter 3 describes the method for improvement and development of wireless LAN technology. Chapter 4 shows the results of roaming method for wireless LAN. Lastly, the final chapter would summarize our research.

CHAPTER II

LITERATURE REVIEW AND THEORY

This chapter discusses the effective solutions to wireless accessibility. With the growth of the internet usage demand on real-time communication systems, the wireless technology has dramatically impacted our lifestyle as well as the wireless technology has been improved. Each type of wireless technology has the specific characteristics, which is suitable for various tasks. Bluetooth technology is suitable for small distance communications without network speed requirement, whereas wireless LAN technology is made for longer distance and massive data communication.

Wireless LAN is chosen as a suitable solution technology by various reasons. First, wireless LAN installation does not need a radio license from a government agency, whereas other types of wireless technology, such as mobile phone technology, require the mobile's user to obtain a radio license for using a certain radio frequency. Obtaining a radio license also means more operational costs. Wireless LAN technology can also transmit the data with high speed networks with a number of applications. Therefore, most users choose the wireless LAN as a base technology.

2.1 Wireless LAN History

In 1980, a wireless LAN network was firstly adopted with 900 MHz radio frequency on ISM Band, the same frequency as cellular phones. The transmission could be done through it. It was cheap and convenient to use with its popularity.

In 1990, a wireless LAN network using 2.4 GHz radio frequency was developed. In 1992, an institution of IEEE defined the wireless LAN standard of IEEE 802.11 with the different versions of wireless models as shown in the Figure 2.1.

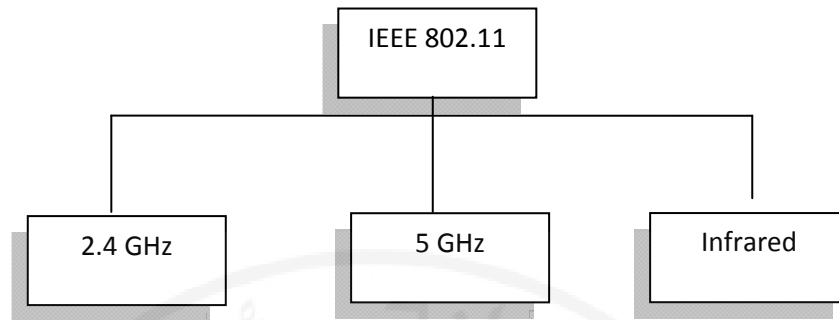

Figure 2.1 Types of Wireless LAN on 802.11 Standards.

Wireless LAN standards can be divided into three major groups according to its frequency: 2.4 GHz, 5 GHz, and infrared.

2.2 Wireless standard 802.11

This is the most common wireless standard adopted due to the transmission power of radio waves. It can transmit data for up to 100 meters indoor and 400 meters outdoor in theory. In practice, the numbers are only about a third. It can achieve a speed of 11 to 54 Mbps. Wireless standards can also be subdivided into four groups, given as: a, b, g and n. Each standard is distinct on how it modulates its signal on carrier frequency with efficiency. The Wireless LAN standards of 802.11 are described as follows:

- Standard 802.11b is the most common wireless standard, because its frequency of 2.4 GHz is a frequency level that can be utilized.
- Standard 802.11g is a wireless standard started in 2003 with a maximum network speed of 54 Mbps. It can also achieve the same distance and same frequency as 802.11b standard.
- Standard 802.11a is a standard that was developed the same time as 802.11b standard, but it is not commonly used.
- Standard 802.11n is a standard in 2005 and it can achieve a maximum network speed of 200 Mbps. It has several features of internet communication system, called “Multiple Input Multiple Output (MIMO)”, MIMO enhances the network speed of data transmission as shown in Figure 2.1.

Table 2.1 Characteristics of wireless network technology.

Type of WiFi Standards	Type of Modulations	Maximum Speed rate (Mbps)	Maximum Distance (Meters)		Frequency (GHz)
			Indoor	Outdoor	
IEEE 802.11a	OFDM	54	35	120	5
IEEE 802.11b	DSSS	11	35	140	2.4
IEEE 802.11g	DSSS, OFDM	54	38	140	2.4
IEEE 802.11n	OFDM	100	70	250	2.4/5

2.3 Amplitude

The variable determining the strength of signal is an amplitude, whereas the distance between the peaks is a wavelength.

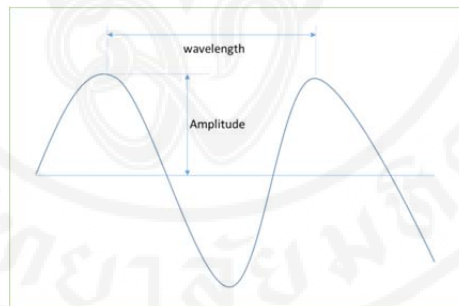

Figure 2.2 Amplitude and wave length of waveform.

2.4 Obstacles of wireless LAN signal strength

2.4.1 Deterioration of WiFi signal strength from distance

Signal strength varies inversely with distance in a vacuum. This is called “Free Space Loss”.

2.4.2 Deterioration of WiFi signal strength by obstacles

Medium obstacles such as walls, windows, glass, and floors can absorb waves. Its absorption will depend on the materials explained below.

2.4.2.1 Walls will decrease the signals strength by 10 to 15 dB depending on its thickness.

2.4.2.2 Building floors will decrease the signals strength by 12 – 27 dB depending on the thickness.

2.4.2.3 Glass panels do not have a signification deterioration. However, if it is coated with mercury, it will decrease signal strength significantly.

2.4.3 Dispersion of signals due to sender and receiver distance

Waves reflect through obstacles and disperse into different directions, which deteriorates signal strength.

2.5 Wavelength and bandwidth intervals of wireless LAN

The first window of frequency of a wireless LAN system usually starts at 2.412 MHz, with the channel bandwidth of 5 MHz higher. Totally, there are thirteen channels, but only three channels are in use without any overlapping channels that could disrupt on wireless LAN systems. Frequencies can be divided into sets of non-overlapping channels according to the following rule: the first set is the 1st, 6th, and 11th channel; the second set is the 2nd, 7th, and 12th channel; the third set is the 3rd, 8th, and 13th channel; the fourth set is the 4th and 9th channel; and the fifth set is the 5th and 10th channel. In practice, only one of these sets should be used.

2.6 Throughput of non-complying wireless systems

WiFi signal communications between client WiFi card and access point are applied with the same frequency. Sending and receiving signals cannot be done simultaneously with Half-Duplex mode.



Figure 2.3 The operation of Wireless LAN protocols on Carrier Sense Multiple Access with Collision Detection (CSMA/CD).

2.7 Throughput distance of wireless LAN

Throughput distance depends on the overhead, sending capacity, and gains of the sender.

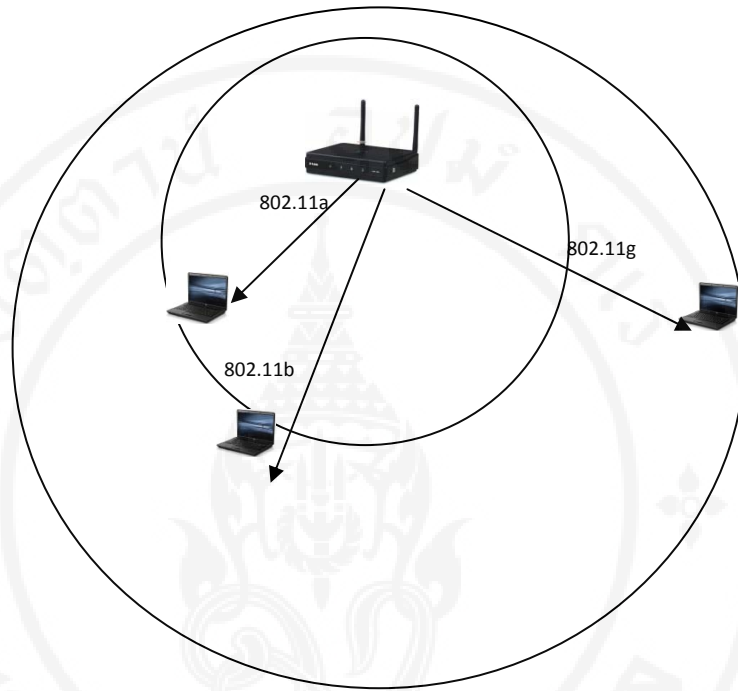

Figure 2.4 The scope of service area networks, wireless LAN standard IEEE 802.11 a, b, and g.

2.8 Service area analysis

It is found the internet service in some inpatient room is unavailable with the lack of WiFi signal strength. A survey found that inpatient accommodation's partitions are made of cement. There are 17 inpatient rooms in an L-shape as shown in Figure 2.5.

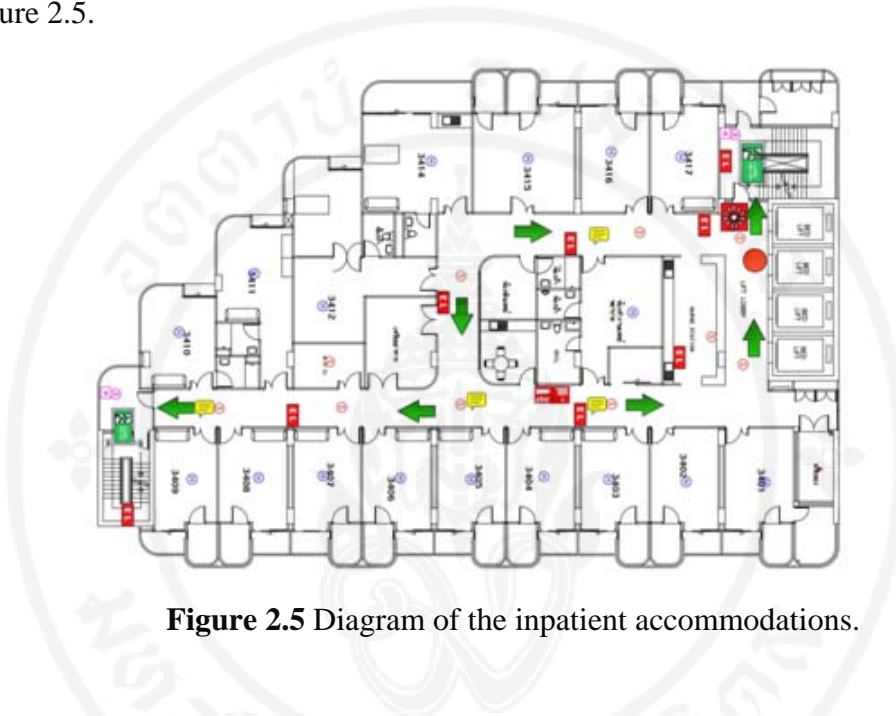

Figure 2.5 Diagram of the inpatient accommodations.

With inpatient room there are three access points; two in front of individual patient's resting areas and one in front of the entire inpatient room. A survey found that the entire inpatient room could not effectively receive wireless service. A site survey is conducted to find the wireless signal strength in different areas from the access points in order to find the optimal locations of access points by using the InSSIDer program.

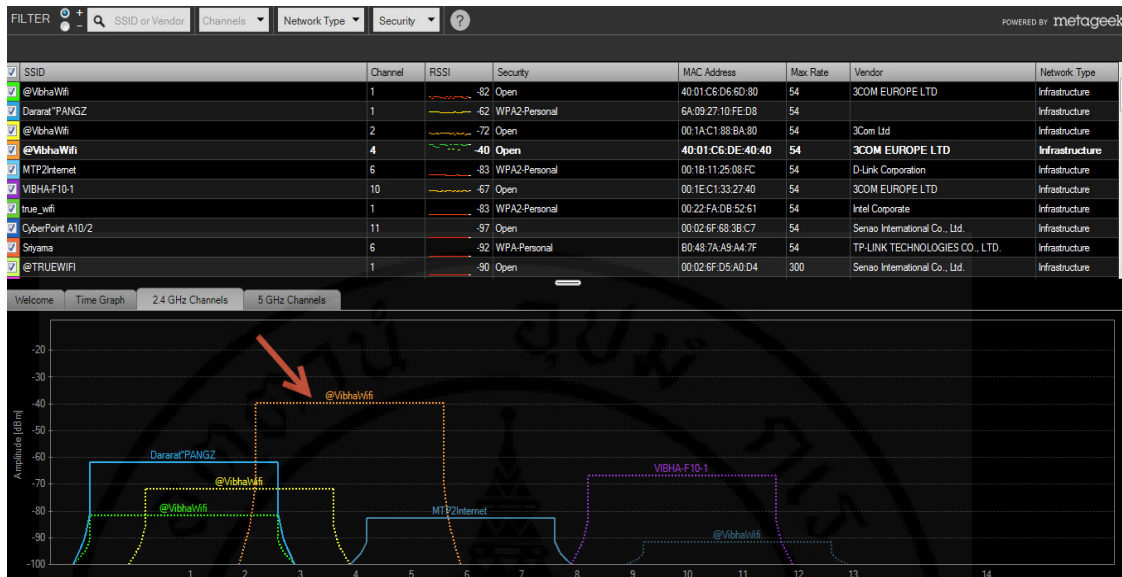

Figure 2.6 Wireless network monitoring program of InSSIDer.

The program will monitor the wireless signal strength at a distance from the access point in different areas including inpatient room and corridor without any obstacle. The different signal strength values of both areas are then compared.

2.9 Related Researches

People use WiFi technology to facilitate data transmission in daily life. Data is quickly sent from a transmitter to a receiver through the air, because it skips three ways handshake step (connectionless communication). However, data has a chance to loss due to the low signal of sending data under the movement among places. In related researches, we compare applications that are used to improve the WiFi efficiency in the hospital.

Firstly, Pang et al. [1] proposed WiFi Reports: Improving Wireless Network Selection with Collaboration. The WiFi Report that provide the historical information of each Access Point (AP). AP was divided into two main uses: the first one is to provide hotspot database with performance details. The second one is enable user to select more visible AP within user’s location effectively. This idea was taken from the problem of existing commercial WiFi usage. User cannot predict whether the selected AP is enabling to connect to all applications, and which AP speed suitable for each usage is. Therefore, users pay a lot of money to buy WiFi, but cannot use it

annotated effectively. In the proposed WiFi Report, connection status, blocking, and capacity details are provided to user. User could predict the AP performance from the summarized statistic. To measurement this study, Pang et al. [1] used the diversity, rank ability, and predictability for considering. In rank ability, the ranking AP did not precise, because the result on official AP was shown that it was not the best choice at 30 percent of hotspot locations. The variability was much smaller than the range of different APs' performance. Hence, the historical information could be used to predict to compare APs. For the last measurement, throughput and latency have the significant diversities. From getting results, the collaborative reporting service helps to support decision on AP Selection.

Niyato et al. [2] proposed an integration of WiMAX and WiFi with Optimal Pricing for Bandwidth Sharing. Bandwidth sharing between a WiMAX BS and WiFi APs/routers were analyzed with optimal pricing by using game theory. A genetic algorithm, the solution of the theory, is repeatedly obtained when the demand information of bandwidth is unavailable. As the result, the proposed method was useful for WiMax and WiFi service provider to integrate the network.

Lastly, Li et al. [3] proposed the use of two global positioning system satellites (GPS) to improve wireless fidelity positioning accuracy in urban canyons. With the problem of two numbers of visible satellites in the critical environment, Li solved the problem by integrating WiFi positioning technology and GPS to improve the positioning accuracy. Moreover, the pseudo range observations were used to generate a time difference of arrival measurement (TDOA). The TDOA will generate a hyperboloid surface and shows the position of user. The result was shown that the method could be able to improve the accuracy more than 50%, and it was an alternative way to be applied in the real practice.

CHAPTER III

PROPOSED MODELS

3.1 Hospital applications

Wireless reception problems in the hospital are given that wireless receptor equipments such as smart phones, tablets, and laptops are not in the line of signal. Concrete walls are blocking its transmission. The following chapter discusses the solutions and the optimal locations of access points.

3.2 Wireless LAN survey

A site survey is done to find wireless signal strength in different locations in the hospital to ensure that wireless signal can be received throughout the hospital. A site survey should start by walking away from an access point in a hallway. It is found that signal strength quickly deteriorates as distance from the access point decreases. Then signal strength is measured when a receiver is in a different room than the access point. A site survey also ensures its usage practicality by testing the wireless signals in closed rooms, where the access points are outside of these rooms.

3.3 Current WiFi systems

The existing system has three wireless access points; two in front of the patient's ward and one in the central patient area. It is found that the patient's ward is shaped like the letter L as shown in Figure 3.1.

The second location from the access point is in front of a patient's room 8 meters away from the access point. It is found that signal strength is -44 dB which can still receive internet signal.

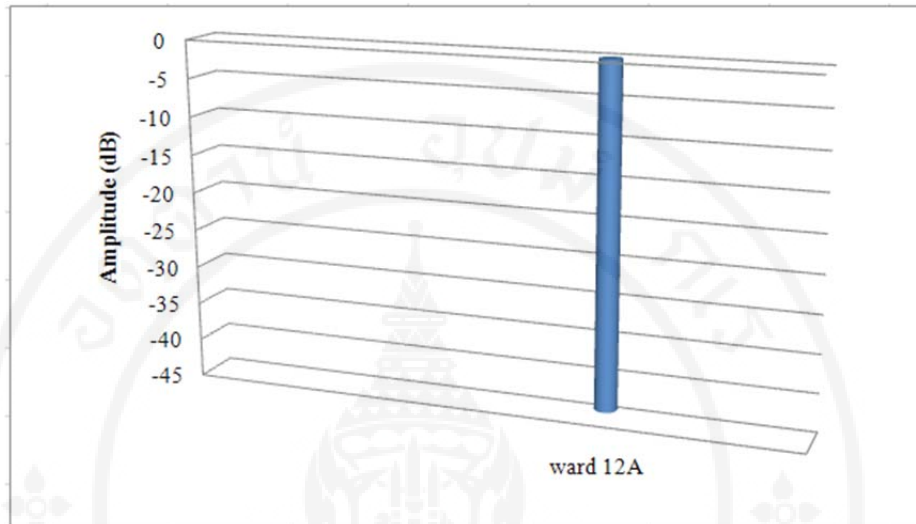

Figure 3.3 Signal strength at a distance of 8 meters.

The third location measured is behind a 9 centimeters thick cement wall. It is found that signal strength deteriorated by twofold with a signal strength -66 dB. The internet cannot be accessed at this point. Its signal strength is shown in Figure 3.4.

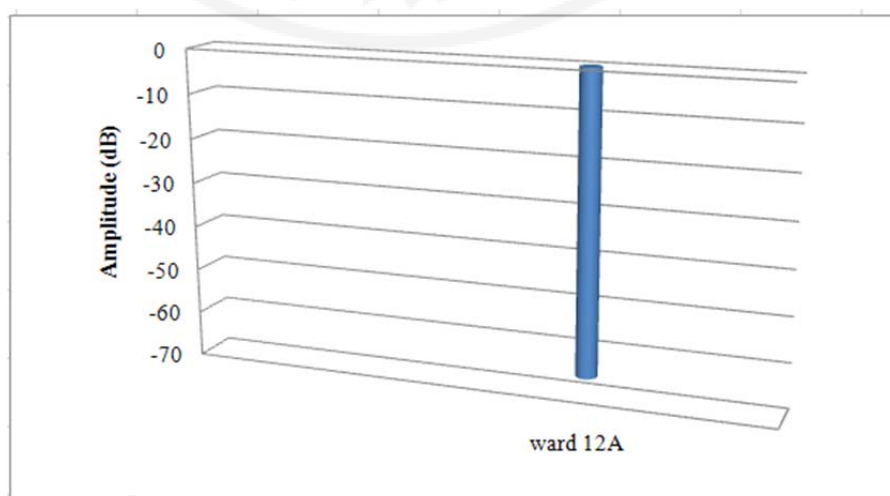

Figure 3.4 Signal strength behind a wall.

The fourth point measured is from a patient's bed. It is found that signal strength is -85 dB which cannot detect the WiFi signal. Sometimes, WiFi signal can be found, but the internet cannot be accessed as shown in Figure 3.5.

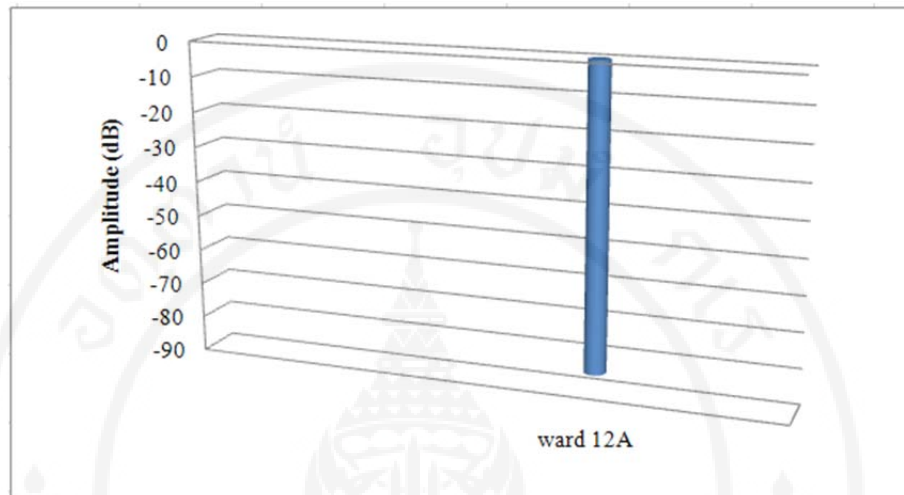

Figure 3.5 The signal strength of the patient's bed.

Here are the following reasons why signal strength measured at a patient's bed is reduced to -85 dB causing internet inaccessibility:

- The deterioration of signals every 15 meters;
- The deterioration of signals through cement walls;
- The deterioration of signals among the room partitions with cement walls;
- This deterioration is found to be 45 dB.

3.4 Determining signal strength between the sender and receiver (Link Margin)

To determine the signal strength between the sender and the receiver (Link Margin), we need to analyze the following variables:

- Radio wave transmit power,
- Transmit antenna gain,
- Transmit cable loss,
- Receive antenna gain,

- Minimum received signal level,
- Receive cable loss.

Signal strength is measured in decibels, (dB) the most convenient measurement relative to other methods. The following table represents the connectivity strength (link margin).

Table 3.1 Connectivity strength (link margin).

Tx Power		23 dBm
Pigtail loss		- 3 dB
Main Cable loss		- 0.5 dB
Tx Antenna gain		3.0 dBi
Sending effectiveness (EIRP)	Sub total	22.5 dBm
Minimum signal strength required (Rx sensitivity)		-83 dBm
Link Margin	Total	105.5 dB

3.4.1 Maximum distance calculation

For the calculation of the maximum distance required in a wireless LAN system, calculation of the deterioration of signals in a vacuum (or free space loss) is not sufficient. In normal conditions, wireless signal deterioration is much greater than other wavelengths. This calculation involves the allowed loss, scattering exponent, and link margin, given as:

$$\text{Link Margin (dB)} = 40 + 10n \log(r) + L_{\text{Allowed loss}} \quad (3.1)$$

Table 3.2 The factor variables for in calculation of the maximum distance.

Characteristics	Allowed Loss	Scattering Exponent	sample
External applications open	0	2.5 at 200 meter 3 at 400 meter 3.5 > 500 meter	Open areas without trees
Used outside the building	0	4	Building area
In building the barrier	0	2.5	Conference hall
The complex has a partition wall.	0	3.5	Office
In buildings with walls	12 - 27 (Ground) 10 - 15 (Wall)	4 - 5	condominium The Apartments

3.4.1.1 Case I

From Eq.(3.1), the following Equation is to determine the maximum distance between the access point and receiver, when there are no obstacles such as in a hallway, given as:

$$\text{Link Margin (dB)} = 40 + 10n \log(r) + L_{\text{allowed loss}},$$

$$105.5 = 40 + 10(2.5) \log(r) + 0,$$

$$r = 70 \text{ meters.}$$

3.4.1.2 Case II

The following Equation is to determine the maximum distance between the access point and a receiver when there is a cement wall as the obstacle, given as:

$$\text{Link Margin (dB)} = 40 + 10n \log(r) + L_{\text{allowed loss}},$$

$$105.5 = 40 + 10(4) \log(r) + 12,$$

$$r = 40 \text{ meters.}$$

3.5 Expansion of the wireless LAN network

The expansion of the existing wireless LAN network can be done in the following methods so that it can be accessed from a further distance.

- Roaming.
- Upgrading the access point with a high gain antenna.
- Adding wattage to an access point via a signal booster.
- Adding a wireless repeater.

3.6 Roaming method

Additional roaming method refers to the installation of access points in blind spots area to ensure the overlapping radiuses of WiFi signals among the existing access points for applying the wireless LAN infrastructure. Therefore, the users enable to access the WiFi service under the movement with the different locations on the radius area of WiFi signal service of access points.

To install a new access point, a new SSID much be matched with the SSID of existing access points. UTP CAT5 wires that are less than 100 meters long have to be linked between the Ethernet hubs/switches.

3.7 Upgrading the access point with the high gain antenna

To expand the wireless LAN network, Omni-directional cables of access points with Gains less than 2.2 dBi are replaced with the cable with higher gain of 5.2 dBi to 12 dBi, respectively. It would increase the effectiveness for sending and receiving data between the access point and client users. Wifi's transmission distance would be increased.

3.8 Adding the WiFi signal booster

A WiFi signal booster, also called an amplifier, enables to increase the distance in which wireless signals can be sent/received. For data transmission, the WiFi signal booster is to amplify the WiFi signal strength from 30 – 50 mW to a 100 mW.

3.9 Adding the wireless repeater

A wireless repeater will recheck the signaling data to ensure the connectivity between an access point and wireless clients within the signaling radius area of the wireless repeater installation, whereas the WiFi clients seem to be directly connected with access points.

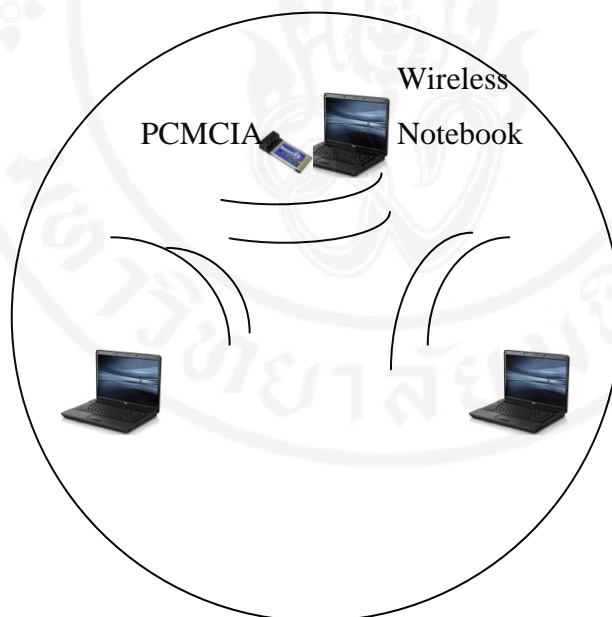

Figure 3.6 Structure and mechanism of wireless LAN networks.

The Figure 3.6 shows a triangle surround an equipment. The circle represents the access radius of service area. All equipment in the figure uses the same frequency. This represents a Basic Service Set (BSS) without a central access point. It is similar to an ad-hoc wireless LAN system.

If a BSS has a wireless LAN system that connects the equipment to each other without UTP cable connection on LAN, it is called an Independent Basic Service Set (IBSS). The access point connecting with Ethernet hub/switch by UTP cable is called Basic Service Set Infrastructure (BSSI).

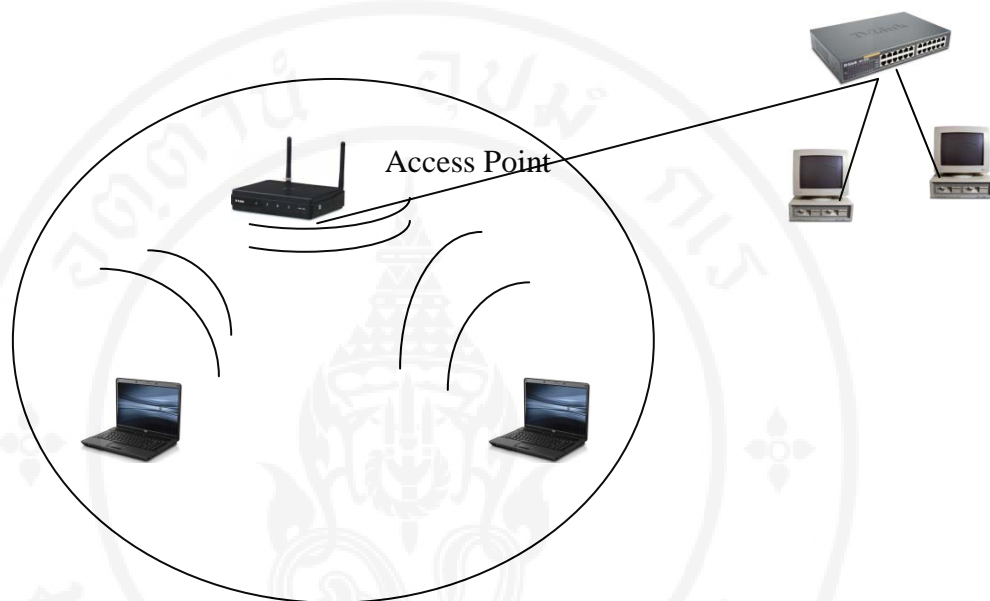

Figure 3.7 Basic Service Set infrastructure (BSSI).

3.10 Extended Service Set (ESS)

When a wireless client has moved outside the accessible radius from the service point, internet communications can be disrupted. An Extended Service Set (ESS) comprises of different Infrastructure BSS systems connected to each other on the Ethernet.

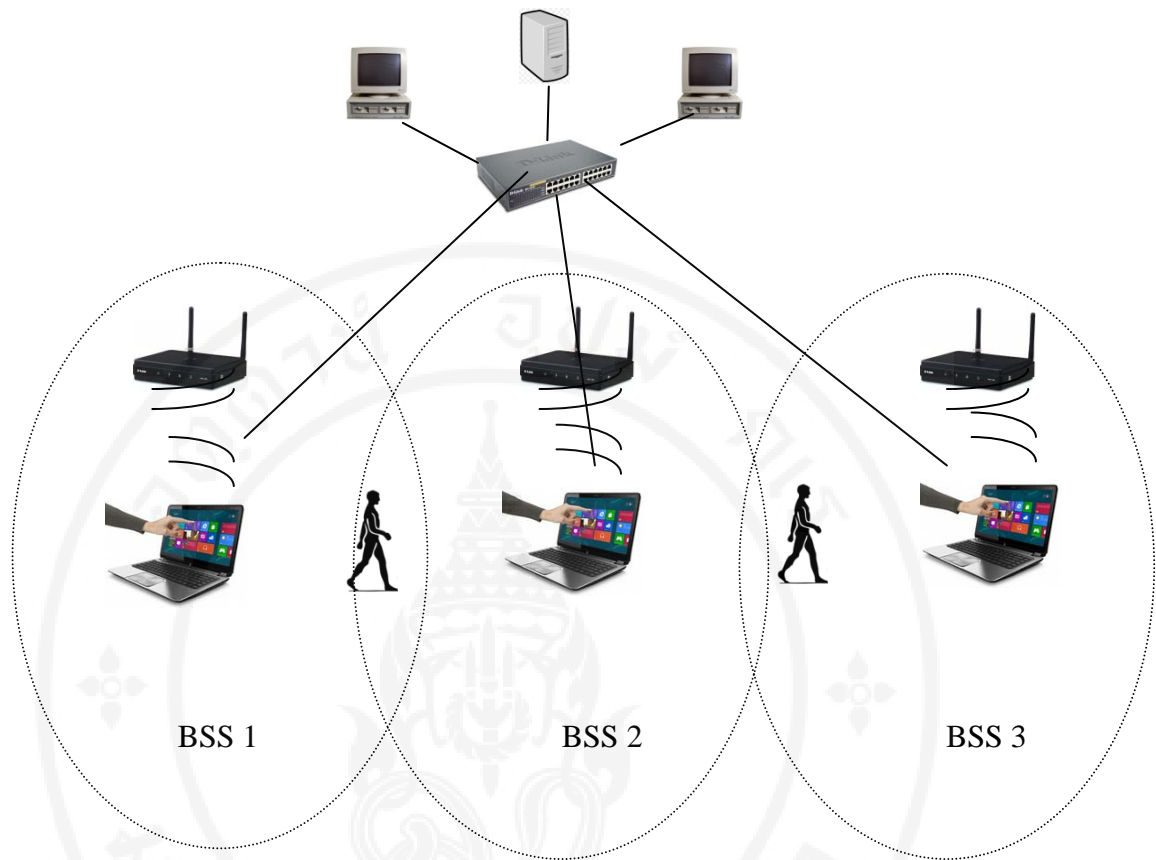

Figure 3.8 The Extended Service Set (ESS) on Wireless LAN network.

To resolve the wireless LAN's blind spot area problems, users have to check the signaling blind spot areas to increase the opportunity for accessing the WiFi service.

3.11 Improvement procedure

1. Conduct a site survey with a wireless detection program of InSSIDer to detect wireless LAN signals.
2. Integrate the following issues:
 - a. Cement walls can deteriorate signals up to 10-15 dB depending on its thickness;
 - b. A site survey found that a 9 centimeter wall can deteriorate wireless signals by 20 dB.

3. Expand the service areas of wireless LAN by Roaming method as follows:

- a. Install the access points in blind spots area by ensuring that the radius between two access points are overlapping and ensuring that each access point has infrastructure qualities;
- b. Assign a new SSID with existing SSIDs;
- c. Choose a different frequency to avoid disruption between different access points. For example, choosing the channels of 1-st, 6-th and 11-th, respectively.

3.12 The proposed WiFi system

The WiFi access point (AP) has been changed with ARUBA AP-105. Its characteristics are given as follows:



Figure 3.9 ARUBA AP-105.

3.12.1 Wireless AP Specifications

General features of wireless AP

- AP type: Dual-radio, dual-band 802.11n indoor;
- Software-configurable dual radio supports 2.4 GHz and 5 GHz;
- 2x2 MIMO 802.11n with two spatial streams and up to 300 Mbps per radio.

Frequency bands supported (country-specific restrictions apply)

- 2.400 to 2.4835 GHz;
- 5.150 to 5.250 GHz;
- 5.250 to 5.350 GHz;
- 5.470 to 5.725 GHz;
- 5.725 to 5.875 GHz.

Transmit power

- Configurable in increments of 0.5 dBm.

Maximum transmit power:

- 2.4 GHz: 23 dBm (limited by local regulatory requirements);
- 5 GHz: 23 dBm (limited by local regulatory requirements).

Association rates (Mbps):

- 802.11b: 1, 2, 5.5, 11;
- 802.11a/g: 6, 9, 12, 18, 24, 36, 48, 54;
- 802.11n: MCS0 to MCS15 (6.5 Mbps to 300 Mbps).

Input power

- 48 volts DC 802.3af power over Ethernet (PoE);
- 12 volts DC for external AC supplied power (adapter sold separately);
- Maximum power consumption: 12.5 watts.

Antenna

- RF interconnect attenuation (between radio and connectors or antennas): 0.5 dB;
- AP-104 and IAP-104: Four RP-SMA connectors for external single-band antennas;

- AP-105 and IAP-105: Four integrated down tilt omni-directional antennas for 2x2 MIMO with maximum antenna gain of 3.0 dBi in 2.4 GHz and 4.5 dBi in 5 GHz.

3.13 Access point location determination

A new access point is added at the end of the patient's ward by installing an access point on the ceiling. Furthermore, a new site survey is conducted from the four access points shown in Figure 3.10.



Figure 3.10 Diagram of the installed access points on the 12A-th floor of inpatient, Vibhavadi hospital.

A new site survey is conducted where InSSIDer is again used to detect signal strength at different locations. From Eq. (3.1), it shows a new signal strength of -32dB at the distance of one meter far away from the newly installed access point.

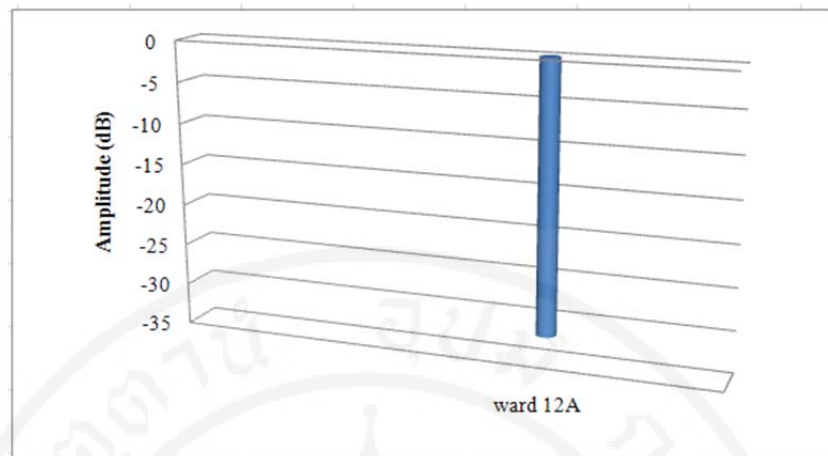

Figure 3.11 The signal strength under the access point.

The second survey is conducted in front of a patient's room which is far away from access point with 8 meters. Signal strength is found to be -41 dB as shown in Figure 3.12. This is strong enough to detect internet signals.

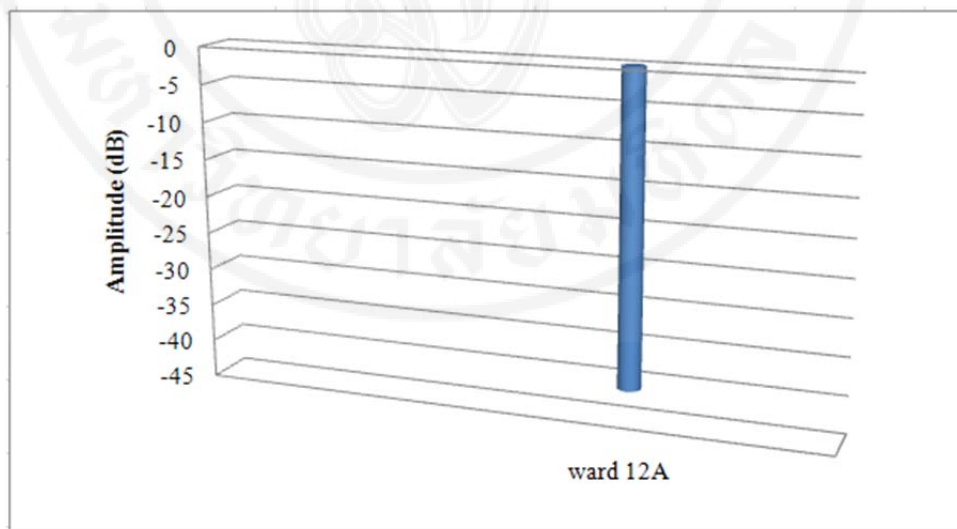

Figure 3.12 Signal strength at a distance of 8 meters.

The third survey is conducted behind a patient's ward with a 9 centimeter, thick of cement wall obstacle. Signal strength detected is -55 dB and the internet can be accessed as shown in Figure 3.13

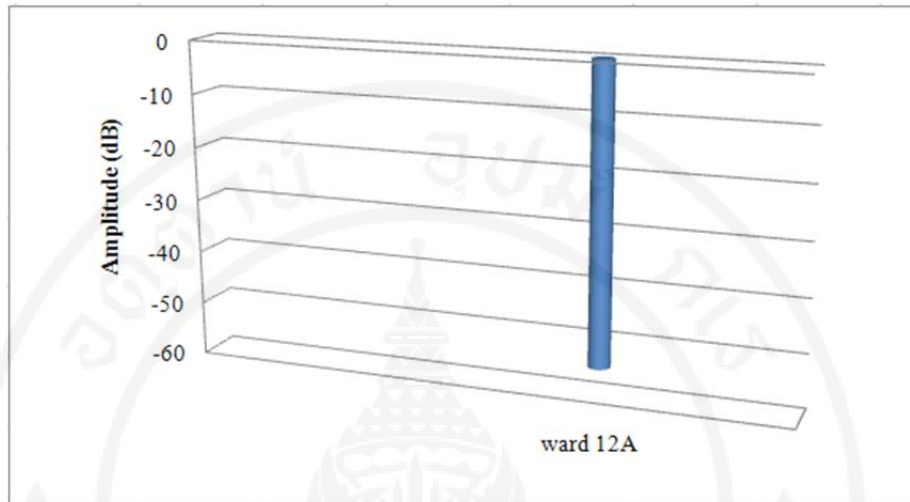

Figure 3.13 The signal strength in the room behind the door.

The fourth survey is conducted at a patient's bed. Signal strength detected is -54 dB, and the internet can be accessed, as shown in Figure 3.14.

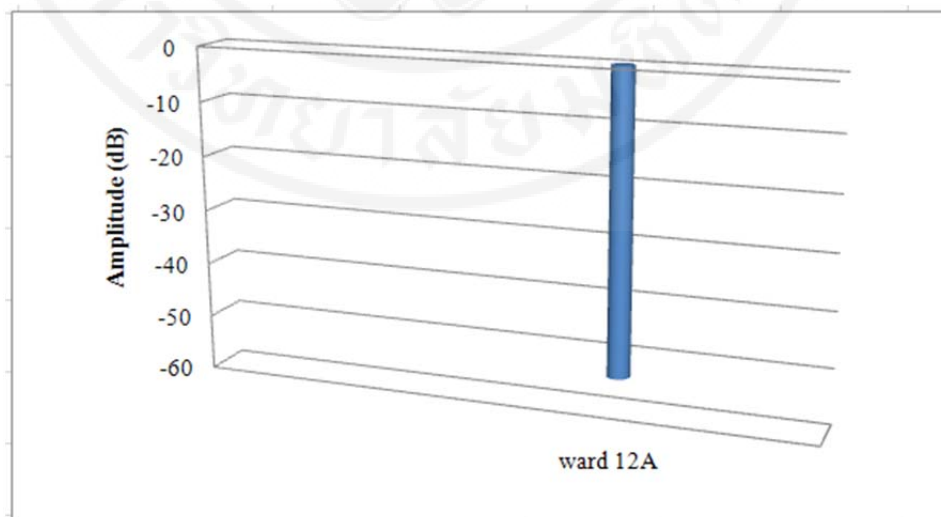

Figure 3.14 The signal strength on the patient's bed.

CHAPTER IV

SIMULATION RESULTS AND DISCUSSION

4.1 Wireless LAN service expansion

This is done via roaming through the following steps:

- 1) Install the access points in the locations of blind spots by ensuring that the radius between two access points are overlapping and ensuring that each access point has infrastructure qualities;
- 2) Assign a new SSID with existing SSIDs;
- 3) Choose a different frequency to avoid the disruption among different access points. For example, channel of 1-st, 6-th, and 11-st are chosen consequently.

An infrastructure characteristic is being applied as shown in Figure 4.1.

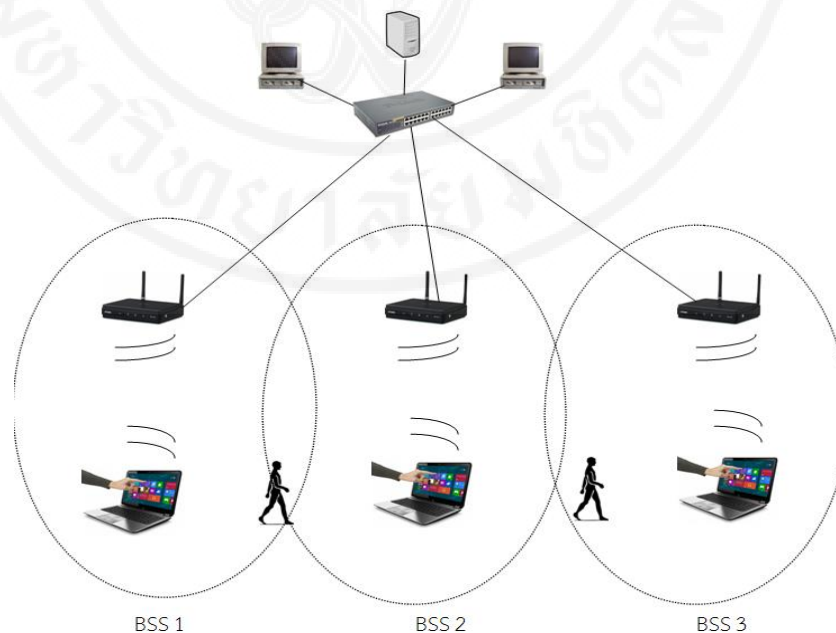

Figure 4.1 Wireless LAN with roaming system.

A wireless signal detection test via InSSIDer at each point before wireless LAN signal is being improved

A site survey before the fourth access point installation found that wireless signal strength decreases from -40 dB to -85 dB in which the internet cannot be accessed. After improving the accessibility in blind spots via roaming, it is found that signals can cover service areas effective with less deterioration from the access point. Wireless signal strength in detection ranges from -32 dB to -54 dB as shown in Figure 4.2.

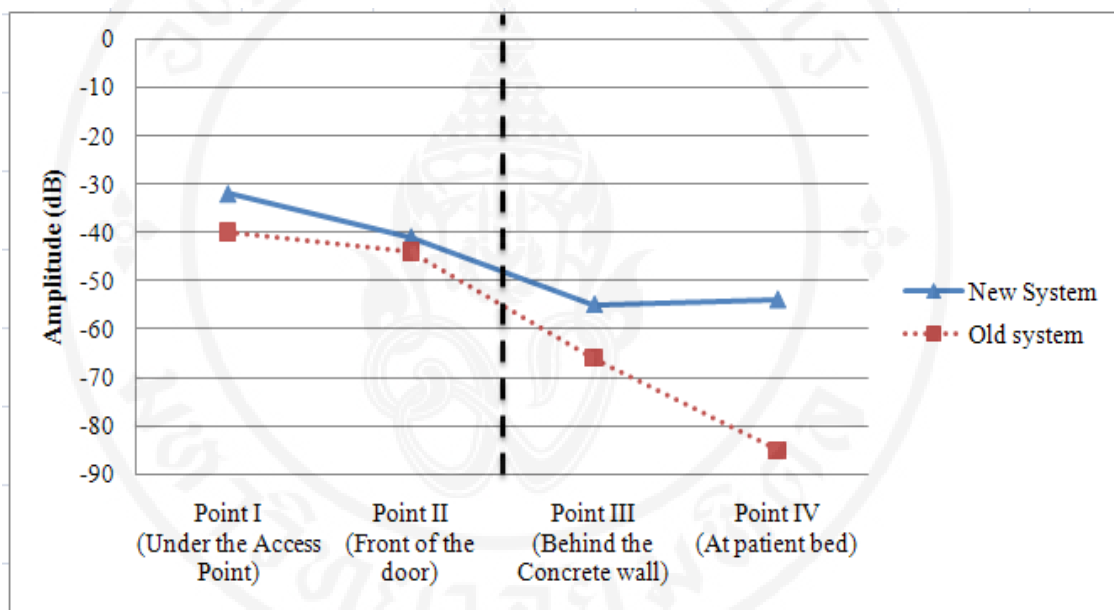

Figure 4.2 The comparison of signal strength results between old system with connection-oriented communication and the purposed system with roaming method.

CHAPTER V

CONCLUSION AND FUTURE WORK

5.1 Conclusion

For our research, Vibhavadi hospital provides the WiFi service cover eleven floors for patients and their visitors. However, the wireless accessibility problem arises on 12A-th floor which is improved in research.

A wireless detection program, called InSSIDer, is used to detect WiFi signals with different locations in 12A-th floor. It is found that signal strength ranges from -40 dB to -85 dB in which the internet cannot be used.

After roaming is used, it is found that the average signal strength ranges from -32 dB to -54 dB. With less signal deterioration, the customer satisfaction increases.

5.2 Further works.

Additional wireless systems for printer connectivity should be installed. For medical purposes, the hospital should consider providing tablets so that doctors can prescribe medications through a wireless system with data recorded in Hospital Information System (HIS). These are just a few applications that can be achieved with internet connectivity.

REFERENCES

1. Pang J, Greenstein B, Kaminsky M, McCoy D, Seshan S. Wifi-Reports: improving wireless network selection with collaboration. *IEEE Transactions on Mobile Computing*. 2010 Dec; 9(12): 1713-1731.
2. Li B, Khing Tan Y, Dempster AG. Using two global positioning system satellites to improve wireless fidelity positioning accuracy in urban canyons. *IET Communication*. 2011; 5(2):163-171.
3. Niyato D, Hossain E. Integration of WiMAX and WiFi: optimal pricing for bandwidth sharing. *IEEE Communication Magazine*. 2007 May; 140–146.
4. Meemongkol A, Khuntikul A. Design and Installation of Wireless LAN (ออกแบบและติดตั้งเครือข่าย Wireless LAN). Bangkok: Info Press; 2004. (In Thai).



ABBREVIATION AND ACRONYMS

LAN	Local Area Network
BS	Base Station
IP	Internet Protocol
PL	Path Loss
LOS	Line-of-Sight
VHF	Very High Frequency
M	Meter
Km	Kilometer
CSMA/CD	Carrier Sense Multiple Access with Collision Detection
IEEE	Institute of Electrical and Electronics Engineers
WiMAX	Worldwide Interoperability for Microwave Access
AP	Access Point
dB	decibel
BSSI	Basic Service Set infrastructure
ESS	Extended Service Set

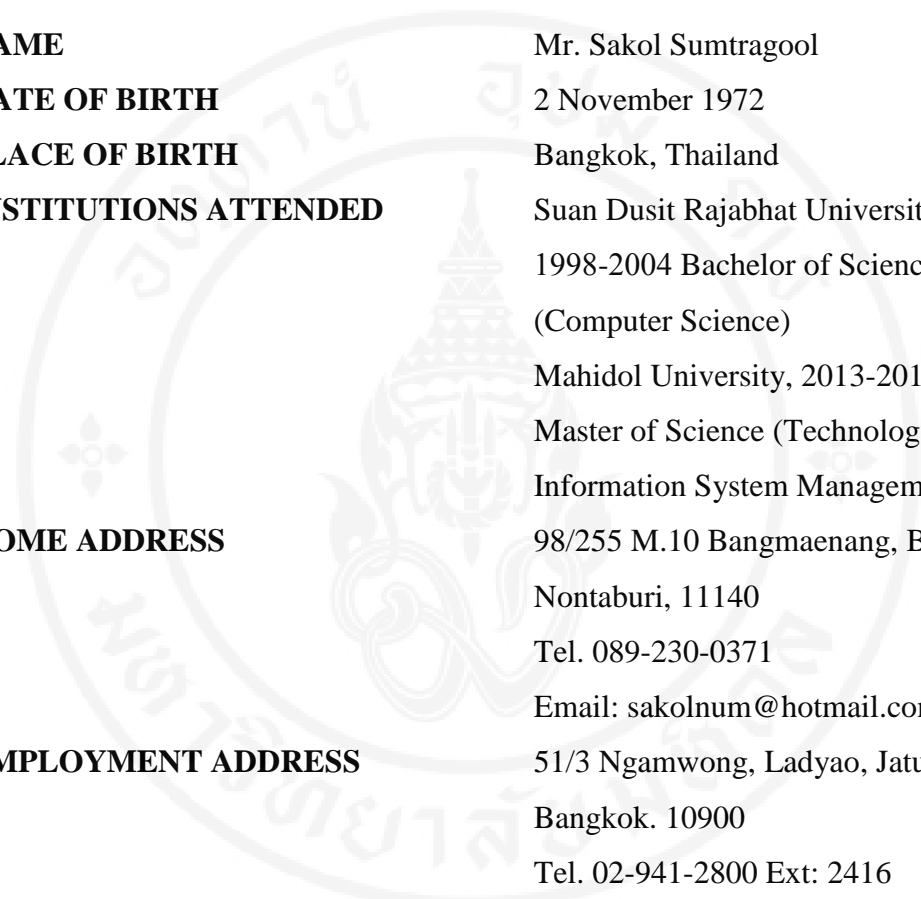
BIOGRAPHY

NAME Mr. Sakol Sumtragool

DATE OF BIRTH 2 November 1972

PLACE OF BIRTH Bangkok, Thailand

INSTITUTIONS ATTENDED Suan Dusit Rajabhat University,
1998-2004 Bachelor of Science
(Computer Science)
Mahidol University, 2013-2014
Master of Science (Technology of
Information System Management)

HOME ADDRESS 98/255 M.10 Bangmaenang, Bangyai
Nontaburi, 11140
Tel. 089-230-0371
Email: sakolnum@hotmail.com

EMPLOYMENT ADDRESS 51/3 Ngamwong, Ladyao, Jatujak
Bangkok. 10900
Tel. 02-941-2800 Ext: 2416