

**DETECTION OF DNA HYBRIDIZATION USING PROTEIN A  
MODIFIED ION SENSITIVE FIELD EFFECT TRANSISTOR**



**NANG MO HOM**

**A THESIS SUBMITTED IN PARTIAL FULFILLMENT  
OF THE REQUIREMENTS FOR  
THE DEGREE OF MASTER OF SCIENCE  
(MEDICAL TECHNOLOGY)  
FACULTY OF GRADUATE STUDIES  
MAHIDOL UNIVERSITY**

Copyright by Mahidol University

**COPYRIGHT OF MAHIDOL UNIVERSITY**

Thesis  
entitled

**DETECTION OF DNA HYBRIDIZATION USING PROTEIN A  
MODIFIED ION SENSITIVE FIELD EFFECT TRANSISTOR**

*Ms. Nang Mo Hom*

Ms. NANG MO HOM,  
Candidate

*Kesara Wat-aksorn*

Asst. Prof. Kesara Wat-aksorn,  
Ph.D. (Microbiology)  
Major-advisor

*Chamras Promptmas*

Asst. Prof. Chamras Promptmas,  
Ph.D. (Biochemistry)  
Co-advisor

*A. Mutchimwong*

Asst. Prof. Auemphorn Mutchimwong,  
Ph.D. (Air Quality Assessment)  
Acting Dean  
Faculty of Graduate Studies  
Mahidol University

*Chotiros Plabplueng*

Asst. Prof. Chotiros Plabplueng,  
Ph.D.  
Program Director  
Master of Science Program in  
Medical Technology  
Faculty of Medical Technology  
Mahidol University

Thesis  
entitled

**DETECTION OF DNA HYBRIDIZATION USING PROTEIN A  
MODIFIED ION SENSITIVE FIELD EFFECT TRANSISTOR**

was submitted to the Faculty of Graduate Studies, Mahidol University  
for the degree of Master of Science (Medical Technology)

on

November 18, 2014



Ms. NANG MO HOM,  
Candidate



Mr. Wutthinan Jeamsaksiri,  
Ph.D. (Electrical Engineering)  
Chair



Asst. Prof. Kesara Wat-aksorn,  
Ph.D. (Microbiology)  
Member



Asst. Prof. Chamras Promptmas,  
Ph.D. (Biochemistry)  
Member



Asst. Prof. Auemphorn Mutchimwong,  
Ph.D. (Air Quality Assessment)  
Acting Dean  
Faculty of Graduate Studies  
Mahidol University

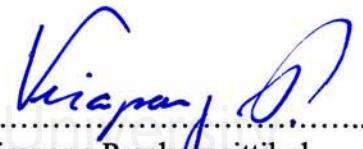

Prof. Virapong Prachayasittikul,  
Ph.D.  
Dean  
Faculty of Medical Technology  
Medical Technology

## ACKNOWLEDGEMENTS

This work would not have been completed and successful without support from many people and organizations. I would like to express the deepest appreciation to everyone who supported me throughout this work.

First of all, I would like to express my special gratitude to my major advisor, Asst. Prof. Dr. Kesara Wat-aksorn for the continuous support of my Master study and research, her excellent guidance, advice, motivation, kindness, and patience.

I would also like to express my sincere gratitude to my co-advisor, Asst. Prof. Dr. Chamras Promptmas for his caring, encouragement, and helping me to figure out many problems during the experiments.

Besides, I would like to thank my thesis external examiner, Dr. Wutthinan Jeamsaksiri for his brilliant comments and suggestions.

I would like to acknowledge the Office of the Higher Education Commission and Mahidol University under the National Research Universities Initiative and the Faculty of Medical Technology, Mahidol University, Thailand. Furthermore, I would like to special thank to Thai Microelectronic Center (TMEC) for providing ISFET and signal measuring devices.

Many thanks go to all BRU lab members, staffs and friends at Faculty of Medical Technology, Mahidol University for their helps, sharing their knowledge and comments.

Last, but by no means least, a special thanks to my parents for their big inspiration and support me throughout my life. They were always supporting me and encouraging me with their best wishes.

Nang Mo Hom

**DETECTION OF DNA HYBRIDIZATION USING PROTEIN A MODIFIED ION SENSITIVE FIELD EFFECT TRANSISTOR**

NANG MO HOM 5537753 MTMT/M

M.Sc. (MEDICAL TECHNOLOGY)

THESIS ADVISORY COMMITTEE: KESARA WAT-AKSORN, Ph.D., CHAMRAS PROMPTMAS, Ph.D.

**ABSTRACT**

A DNA sensor based Ion Sensitive Field Effect Transistor (ISFET) with protein A modification, for the detection of DNA hybridization, was investigated. In this experiment, the surface of the ISFET was first modified with protein A via physical adsorption. Protein A has a sticky property and can bind specifically to the fragment crystallizable (Fc) portion of the antibody leading to the uniform orientation for effectively binding to the antigen. In order to detect DNA hybridization, an anti-biotin antibody was immobilized over protein A and a single-strand biotinylated DNA probe was added to bind to a specific anti-biotin antibody. The voltage shift of DNA/DNA hybridization was observed right after the complementary DNA target was added over the immobilized probe. The non-complementary DNA target was also tested as a negative control. The saturated concentrations for all steps were as follows: 1mg/ml for protein A, 1 mg/ml for anti-biotin antibody, 0.5  $\mu$ M for biotinylated probe, and 0.5  $\mu$ M for synthetic DNA target. As high amount of protein A and anti-biotin may barricade the hybridization signal detection; therefore, in this experiment 0.1 mg/ml of both protein A and anti-biotin were tested instead of their saturated concentrations. Using this strategy, DNA hybridization of the synthetic DNA target was successfully detected with the detection limit approximately at 0.08  $\mu$ M as well as differentiated complementary DNA from non-complementary DNA target.

**KEY WORDS: ISFET / PROTEIN A / DNA HYBRIDIZATION**

56 pages

การตรวจดีเอ็นเอไฮบริดเคชันโดยไบโอเซนเซอร์ชนิดที่มีโปรตีนเอตรึงอยู่บนทรานซิสเตอร์  
สนามไฟฟ้าชนิดไวต่อไอออน

DETECTION OF DNA HYBRIDIZATION USING PROTEIN A MODIFIED ION SENSITIVE  
FIELD EFFECT TRANSISTOR

NANG MO HOM 5537753 MTMT/M

วท.ม. (เทคนิคการแพทย์)

คณะกรรมการที่ปรึกษาวิทยานิพนธ์: เกศรา วัลอักษร, Ph.D., จำรัส พร้อมมาศ, Ph.D.

#### บทคัดย่อ

ดีเอ็นเอเซนเซอร์สำหรับการตรวจดีเอ็นเอไฮบริดเคชัน (DNA hybridization) โดย  
วิธีการตรึงโปรตีนบนผิวทรานซิสเตอร์สนามไฟฟ้าชนิดไวต่อไอออน (ion sensitive field effect  
transistor: ISFET) ได้ถูกพัฒนาขึ้นในการทดลองนี้ โดยใช้โปรตีนเอเคลือบบนผิวของ ISFET เป็น  
ขั้นตอนแรก คุณสมบัติที่โดดเด่นของโปรตีนเอและจำเพาะต่อ Fc ของแอนติบอดีทำให้เกิดการ  
กำหนดทิศทางของแอนติบอดีได้สม่ำเสมอเพื่อให้อัดกับแอนติเจนได้อย่างมีประสิทธิภาพ จากนั้น  
ทำการตรึงแอนติบอดีที่จำเพาะต่อไบโอดีบนชั้นโปรตีนเอ ต่อจากนั้นเติมตัวตรวจจับดีเอ็นเอ  
(DNA probe) จากการสังเคราะห์ที่ติดด้วยไบโอดีเพื่อที่จะตรวจดีเอ็นเอไฮบริดเคชัน แล้วสังเกต  
การเปลี่ยนแปลงความต่างศักย์ที่เกิดขึ้นจากดีเอ็นเอไฮบริดเคชันหลังจากที่เติมดีเอ็นเอเป้าหมายจาก  
การสังเคราะห์ที่จำเพาะต่อตัวตรวจจับดีเอ็นเอ และเปรียบเทียบกับ negative control ซึ่งเป็นดีเอ็นเอ  
เป้าหมายที่ไม่จำเพาะต่อตัวตรวจจับดีเอ็นเอ ผลการศึกษาพบว่าภาวะที่เหมาะสมของโปรตีนเอและ  
แอนติบอดีคือ 1 มิลลิกรัม/มิลลิลิตรและ 0.5 ไมโครโมลาร์สำหรับตัวตรวจจับดีเอ็นเอ และดีเอ็นเอ  
เป้าหมาย เนื่องจากปริมาณที่สูงของโปรตีนเอและแอนติบอดีอาจกีดขวางการตรวจพบดีเอ็นเอไฮบริ  
ดเคชัน ดังนั้น 0.1 มิลลิกรัม/มิลลิลิตรโปรตีนเอและแอนติบอดีได้ถูกนำไปใช้แทน 1 มิลลิกรัม/  
มิลลิลิตรในการทดลองนี้ ผลการทดลองพบว่าสามารถดีเอ็นเอไฮบริดเคชันได้สำเร็จด้วยความ  
เข้มข้นต่ำประมาณ 0.08 ไมโครโมลาร์และสามารถตรวจแยก complementary ดีเอ็นเอจาก non-  
complementary ดีเอ็นเอเป้าหมายได้อย่างชัดเจน

## CONTENTS

	<b>Page</b>
<b>ACKNOWLEDGEMENTS</b>	<b>iii</b>
<b>ABSTRACT (ENGLISH)</b>	<b>iv</b>
<b>ABSTRACT (THAI)</b>	<b>v</b>
<b>LIST OF TABLES</b>	<b>ix</b>
<b>LIST OF FIGURES</b>	<b>x</b>
<b>LIST OF ABBREVIATION</b>	<b>xi</b>
<b>CHAPTER I INTRODUCTION</b>	<b>1</b>
<b>CHAPTER II OBJECTIVE</b>	<b>3</b>
<b>CHAPTER III LITERATURE REVIEW</b>	<b>4</b>
3.1 Biosensor	4
3.1.1 Types of biosensors	5
3.1.1.1 Optical biosensors	5
3.1.1.1.1 Surface plasmon resonance	6
3.1.1.1.2 Fluorescence detection	6
3.1.1.2 Mass-based biosensors	6
3.1.1.2.1 Piezoelectric biosensor	6
3.1.1.2.2 Microcantilever	7
3.1.1.3 Electrochemical biosensors	7
3.1.1.3.1 Amperometric biosensor	7
3.1.1.3.2 Impedimetric biosensor	8
3.1.1.3.3 Conductometric biosensor	9
3.1.1.3.4 Potentiometric biosensor	9
3.1.1.4 Enzyme-based biosensor	9
3.1.1.5 Antibody-based biosensor	10
3.1.1.6 Cell-based biosensor	10
3.1.1.7 DNA-based biosensor	10



## CONTENTS (cont.)

	<b>Page</b>
4.2.1.2 Electric measurements of ISFET	28
4.2.1.3 DNA-based ISFET sensor steps	29
4.2.2 Experiments	31
4.2.2.1 Evaluation of ISFET quality	31
4.2.2.2 Modification of ISFET surface	31
4.2.2.2.1 Optimization of Protein A Concentration	31
4.2.2.2.2 Optimization of Anti-biotin Antibody Concentration	31
4.2.2.2.3 Optimization of Biotinylated DNA Probe Concentration	32
4.2.2.2.4 Detection of Synthetic Complementary DNA target	32
4.2.2.2.5 Detection of Non-complementary DNA Target	33
<b>CHAPTER V RESULTS</b>	<b>34</b>
5.1 Evaluation of ISFET quality	34
5.2 Modification of ISFET surface	35
5.2.1 Optimization of Protein A Concentration	35
5.2.2 Optimization of Anti-biotin Antibody Concentration	36
5.2.3 Optimization of Biotinylated DNA Probe Concentration	37
5.2.4 Detection of Synthetic Complementary DNA Target	38
5.2.5 Detection of Non-complementary DNA Target	39
<b>CHAPTER VI DISCUSSION</b>	<b>41</b>
<b>CHAPTER VII CONCLUSION</b>	<b>45</b>
<b>REFERENCES</b>	<b>46</b>
<b>BIOGRAPHY</b>	<b>56</b>

**LIST OF TABLES**

<b>Table</b>		<b>Page</b>
4.1	Sequences of oligonucleotides used in this study	25
4.2	Formula and molecular weight of chemicals and reagents used in this study	26

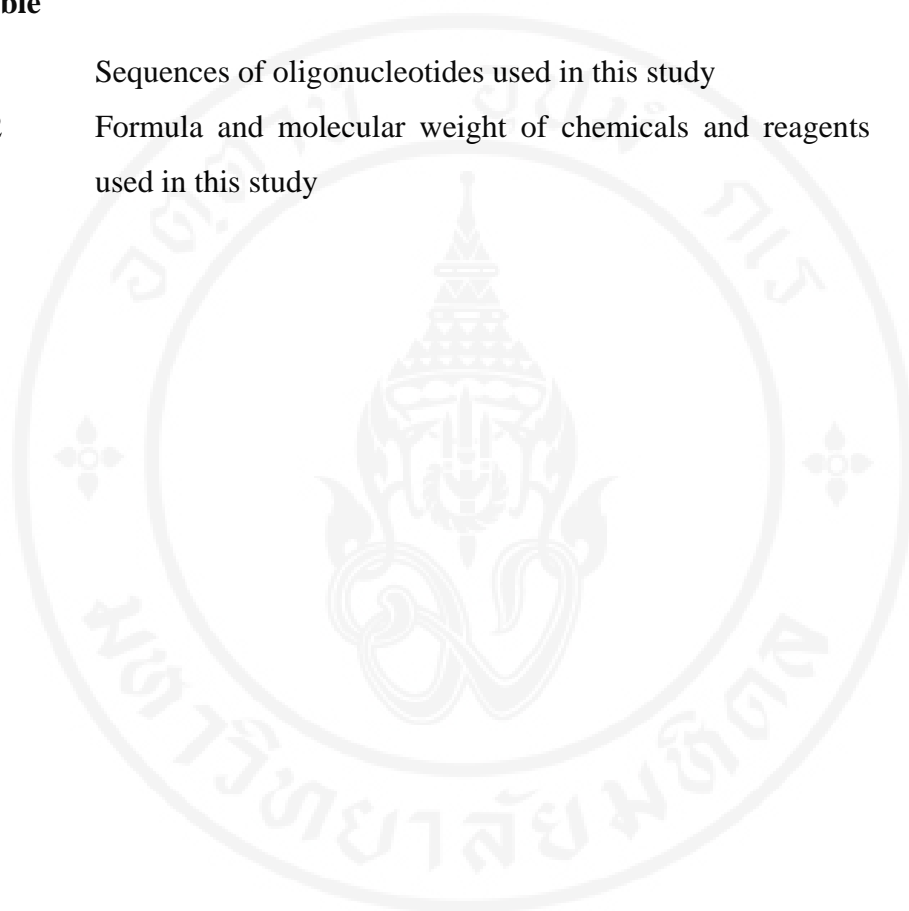

## LIST OF FIGURES

<b>Figure</b>	<b>Page</b>
3.1 Schematic diagram of biosensor	4
3.2 Schematic diagram of DNA-based biosensor	12
3.3 Structures of ISFET and MOSFET	
(a) Schematic diagram of ISFET	14
(b) Schematic diagram of MOSFET	15
3.4 Schematic diagram of silver/silver chloride (Ag/AgCl) reference electrode	16
3.5 Demonstration of the site-binding model which represents the reaction of the proton donor or proton acceptor of the hydroxyl groups	19
3.6 Schematic diagram of the surface functionalization of ISFET	22
4.1 Schematic diagram of the measuring device	29
4.2 Scheme of the steps of the DNA-based ISFET sensor modification	30
5.1 Gate potential of ISFET response to various pH solutions	34
5.2 Optimization of protein A concentration	35
5.3 Optimization of anti-biotin antibody concentration with both 0.1 mg/ml and 1 mg/ml of protein A	37
5.4 Optimization of biotinylated probe concentration	38
5.5 Detection of synthetic complementary DNA target	39
5.6 Comparisons of the potential changes between complementary and non-complementary DNA targets	40

## LIST OF ABBREVIATIONS

<b>Abbreviations</b>	<b>Terms</b>
Al <sub>2</sub> O <sub>3</sub>	Aluminium oxide
APTES	3-aminopropyltriethoxysilane
β	Beta
CNFET	Carbon nanotube field effect transistor
°C	Degree Celsius
DNA	Deoxyribonucleic acid
D	Drain
EIS	Electrochemical impedance spectroscopy
ELISA	Enzyme-linked immunosorbent assay
FET	Field effect transistor
FITC	Fluorescein isothiocyanate
FRET	Foster resonance energy transfer
Fc	Fragment crystallizable
Fab	Fragment antigen-binding
G	Gate
GOx	Glucose oxidase
g	Gram
HRP	Horse radish peroxidase
h	Hour
H <sup>+</sup>	Hydrogen ion
OH <sup>-</sup>	Hydroxide
ISFET	Ion sensitive field effect transistor
JFET	Junction field effect transistor
kDa	Kilo Dalton
L	Litre
MOSFET	Metal oxide semiconductor field effect transistor

## LIST OF ABBREVIATIONS (cont)

MESFET	Metal semiconductor field effect transistor
$\mu\text{g}$	Microgram
$\mu\text{l}$	Microliter
$\mu\text{M}$	Micromole
mg	Milligram
ml	Mililitre
mM	Milimolar
mV	Milivolt
M	Molar
PBS	Phosphate buffer saline
POCT	Point-of- care testing
KCl	Potassium chloride
PA	Protein A
QCM	Quartz crystal microbalance
SPCE	Screen printed carbon electrode
SiOH	Silanol
$\text{Si}_3\text{N}_4$	Silicon nitride
$\text{SiO}_2$	Silicon oxide
Ag	Silver
AgCl	Silver chloride
Ag/AgCl	Silver/silver chloride
S	Source
SD	Standard deviation
SPR	Surface plasmon resonance
$\text{Ta}_2\text{O}_5$	Tantalum pentoxide
TMEC	Thai Microelectronic Center
$V_T$	Threshold voltage

## **CHAPTER I**

### **INTRODUCTION**

Biosensor is a chemical/biological sensing device which incorporates with a transducer to recognize biorecognition element and converts these biological event into measureable signal. The biorecognition elements can be nucleic acid, antibody, enzyme, or cell. The transduction signal can be classified into amperometric, impedimetric, conductometric, and potentiometric based on the observed parameters such as current, impedance, conductance, and potential, respectively. There are also mass-based biosensors: quartz crystal microbalance (QCM), microcantilever, and optical biosensors such as surface plasmon resonance and fluorescence detection. Ion sensitive field effect transistor (ISFET) is potentiometric biosensor. The principle of the potentiometric biosensor is the monitoring of the potential based on the charged molecules deposit onto the sensing membrane. ISFET is a common type of potentiometric biosensor. ISFETs have been increasingly developed for disease diagnosis, biological or chemical sensing and have gained more interest as they are simple, small in size, and cost effective. ISFET was firstly developed by Bergveld in 1970 [45]. It is used for measuring ions concentration or pH in electrolyte. The concept of ISFET originally came from a Metal Oxide Semiconductor Field Effect Transistor (MOSFET). The structure of ISFET is nearly identical to the structure of MOSFET except the metal gate in MOSFET is replaced by the reference electrode in the ISFET. This reference electrode is immersed in an aqueous solution to provide a steady reference potential. The operation of this ISFET is basically the monitoring of the gate potential by controlling the source drain current. The potential change (voltage change) occurs when the charged molecules deposit onto the gate surface when applying an electric field. ISFET can be classified based on its biorecognition element such as DNA-based ISFET, enzyme-based ISFET, immunological-based ISFET, and cell-based ISFET. ISFET has been developed for environmental monitoring by measuring the nutrient level in soil [30], monitoring blood glucose [31,

78], detection of gene mutation, and even pathogens. Recently, much attention has been given to the development of the detection of nucleic acid in research applications as well as in clinical diagnosis. Deoxyribonucleic acid (DNA) detection is important for many diagnosis as well as research applications such as detection of genetic disorders, diagnosis of infectious diseases, screening of cancer related genes, and the discovery of new drugs. Hence, detection methods for specific DNA sequences are extremely important for early stage treatment and disease prevention. There are the alternative ways to detect DNA hybridization such as traditional Southern blot and DNA microarray. These techniques need a radioactive or fluorescent labeling step which is complicated and time consuming. ISFET is one of the choices that can tackle these problems. It is one of the techniques that can be used to detect DNA hybridization without any labeling step. However, ISFET surface modification is necessary to create an appropriate platform for DNA immobilization and detection of the target. Most of ISFET modifications in the previous reports are complex and need time to modify the surface [63]. The method is based on covalent binding by a series of chemical reactions such as cleaning, silanizing, cross-linking, and covalent bonding. To overcome the obstacles mentioned, in this thesis, one of the promising and simple techniques, DNA biosensor based on protein A modified ISFET was investigated. Protein A is advantageous as its sticky property and high affinity binding to the Fc portion of immunoglobulins. It is usually used to immobilize the antibody on sensor surface both physical adsorption and covalent bonding. In this study, it was used to modify the ISFET surface as a suitable base for immobilizing antibody in a high oriented manner. It was simple because protein A was physically adsorbed onto the ISFET surface and required no complicated step to modify the sensor surface.

## **CHAPTER II**

### **OBJECTIVE**

To develop a method for detection of DNA hybridization based on protein  
A modified ion sensitive field effect transistor (ISFET).

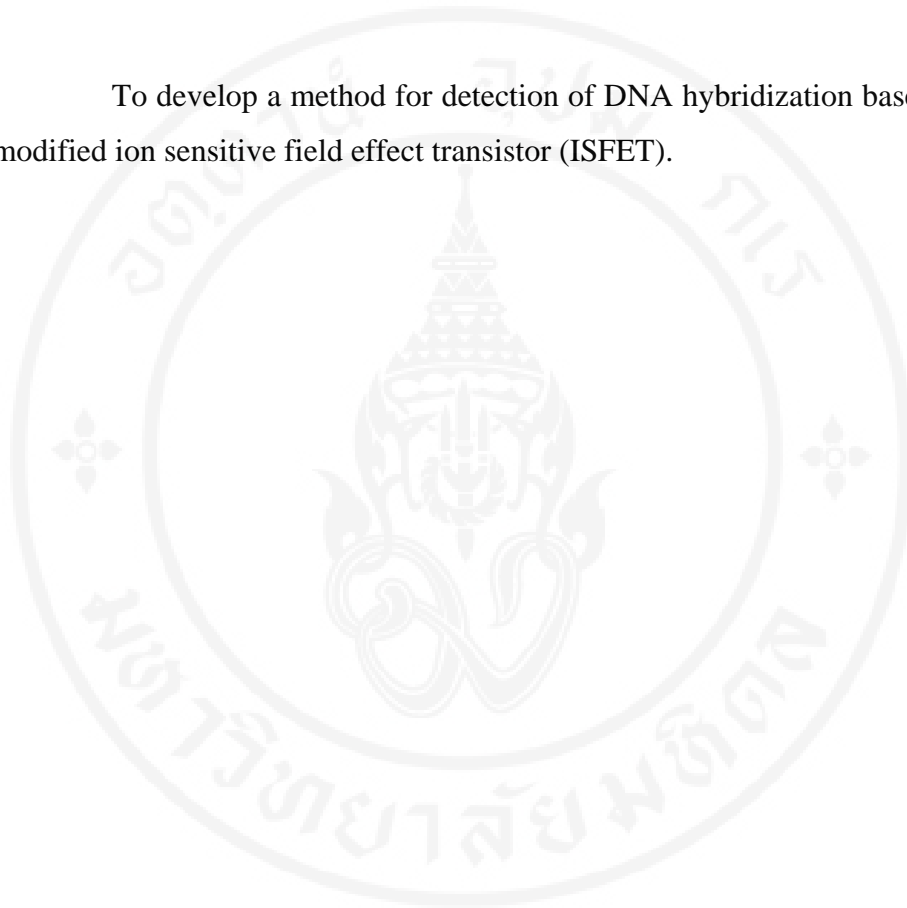

## CHAPTER III

### LITERATURE REVIEW

#### 3.1 Biosensor

Biosensor is an analytical device which converts the molecular recognition event into measurable signal. Generally, it comprises of three main components including bioreceptor, transducer, and signal processor. The bioreceptor recognizes the analyte and transducer transforms the resulting signals from the interaction between the biorecognition element and the target analyte into detectable signal. The signal processor collects, amplifies, and displays the signal. Biosensors can be classified according to their bioreceptors such as enzyme-based biosensor, antibody-based biosensor, cell-based biosensor, and DNA-based biosensor. They can also be classified based on their transducers such as optical based biosensors (surface plasmon resonance, fluorescence detection), mass-based biosensors (piezoelectric biosensor, and cantilever), and electrochemical biosensors such as amperometric, impedimetric, conductometric and potentiometric biosensors. The schematic diagram of biosensors is shown in Figure 3.1.

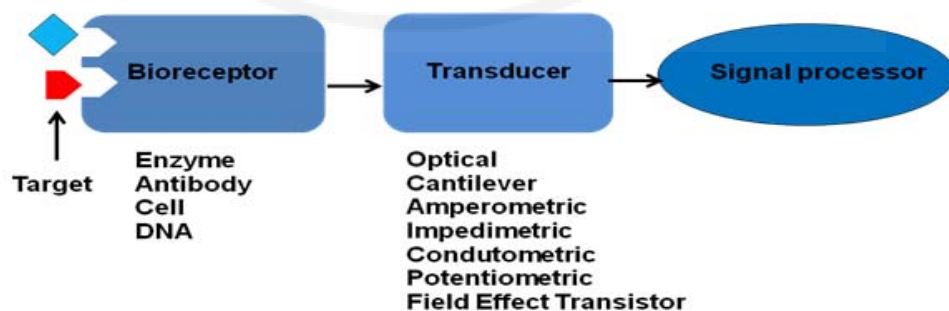

**Figure 3.1 Schematic diagram of biosensor**

The first enzyme-based glucose sensor was developed by Clark and Lyons in 1962 [1]. The first commercial glucose sensor which applied directly on the blood sample based on amperometric detection of hydrogen peroxide was the Yellow Spring

Company Analyzer. It was placed in the market in 1975. Since then, many biosensors have been developed in many research areas globally. At present, there are many commercialized devices used in clinical and pharmaceutical markets. Additionally, biosensor can be applied in a clinical diagnosis such as for monitoring blood glucose [2, 3], lactate, urea, etc. [4], and for screening cancer related genes [5]. The main characteristic of clinical use commercial biosensor is to provide a direct measurement in undiluted blood and customer self-monitoring. It can be employed for diagnosis of infectious diseases by detecting of infectious microorganisms or toxins for food safety [6-9], for environmental or agricultural monitoring by detecting of chemicals such as pesticide level in fruits, vegetables, or soil [10-12]. Moreover, the development of biosensor for military defense is certain important by detecting the chemicals or infectious microorganisms used in the weapons. Biosensors for monitoring the bioterrorism pathogens have also been developed [13-15].

### **3.1.1 Types of biosensors**

Biosensors are classified according to the transducers:

#### **3.1.1.1 Optical biosensors**

In optical biosensor, the detection is based on the adsorption, fluorescence, or light scattering. There are two detection methods such as fluorescence-based detection and label-free detection. In fluorescence-based detection, the biorecognition element is labeled with the fluorescent tags. The presence of the target is indicated by observing the presence of fluorescence. The intensity of the fluorescence indicates the strength of the interaction between the biorecognition molecule and the target. However, this type of technique is time-consuming and laborious whereas label-free detection is easy to perform and required no additional reagent. In label-free detection, it is usually measure the refractive index change caused by the interaction of bioreceptors and the targets such as surface plasmon resonance. Optical biosensors have been developed for detection of toxins, contaminants, viruses or pathogens [16, 17].

### **3.1.1.1.1 Surface plasmon resonance**

The detection of SPR biosensor is based on the changes in refractive index at the interface of the gold thin film when the target analyte interacts with the bioreceptor immobilized on the sensor surface. The refractive index change is directly proportional to the amount of the surface bound molecules. This technique is complex, expensive and large in size since these are the drawbacks of the technique. SPR biosensors for detection of *Escherichia coli* O157: H7 and methicillin-resistant *Staphylococcus aureus* [18] and for DNA mutation for cancer related gene detection have been reported [19].

### **3.1.1.1.2 Fluorescence detection**

Fluorescence detection technique depends on the fluorescence intensity measurement which is directly proportional to the concentration of the target analyte. Fluorescence takes place when the molecule of the substance is excited by absorbing the light from the ground state (low energy level) to an excited state (high energy level) and then, it emits light to return to its original low energy level. Commonly used fluorescent tags are fluorescein isothiocyanate (FITC), cyanin 3, alexa flour 546, etc. Fluorescence detection can be conjugated with other techniques such as PCR, Southern blot. In this method, the occurrence of the fluorescence indicates the presence of the interaction between the bioreceptor and the target. Foster resonance energy transfer (FRET) biosensor has been developed for detection of bacteria DNA. This FRET biosensor is based on the transfer of a donor fluorophore to an acceptor fluorophore [20].

## **3.1.1.2 Mass-based biosensors**

### **3.1.1.2.1 Piezoelectric biosensor**

Piezoelectric biosensor is based on the observation of frequency change on quartz crystal microbalance (QCM) surface. The concept of piezoelectric device generally derives from the relationship between the change in mass on the quartz surface and the oscillating frequency. In this sensor, the biorecognition molecule is deposited onto the piezoelectric sensing surface to interact

specifically with the added analyte. The frequency decreases when the mass on the quartz surface increases. Many piezoelectric biosensors have been used for clinical diagnosis as well as research applications [21, 22]. The limitation of QCM sensor is non-specific binding can occur since it is the mass sensor that the surface can bind to any molecules leading the potential to interfere the interaction.

#### **3.1.1.2.2 Microcantilever**

A detection of a microcantilever is based on the change in cantilever bending and vibrational frequency. The cantilever bending occurs when the specific mass of the target analyte is adsorbed on the microcantilever surface. This molecular adsorption causes the vibrational frequency change and deflection of the microcantilever. The deflection of the cantilever is directly proportional to the concentration of the analyte. Microcantilever sensors have been employed for detection of pathogens. Piezoresistive microcantilever-based DNA sensor for detection of *Vibrio cholerae* in food sample has been reported [23].

#### **3.1.1.3 Electrochemical biosensors**

Electrochemical biosensors have been gained more attention as they are simple, low cost, and portability. They are simpler in equipment operation when compared to SPR or QCM biosensors. Moreover, the portable point-of-care testing (POCT) glucose sensor based on the principle of electrochemical sensors have achieved the most significant commercial success. They are classified into amperometric, impedimetric, conductometric and potentiometric based on the observed measurable signals such as the current, impedance, conductance, and potential, respectively.

##### **3.1.1.3.1 Amperometric biosensor**

Amperometry is the most common used of electrochemical biosensor for pathogens detection. It is a method characterized by the measurement of generated current from electrochemical oxidation or reduction reactions and electrons are transferred to an appropriate electrode when applying constant voltage. This sensor detects ions in the solution and measures the changes in

the electric current. The variation of the concentrations of the analyte is directly proportional to the electrons transferred and the current produced. Amperometric biosensor can be operated either two or three electrodes including reference electrode (Ag/AgCl), working electrode, and auxiliary electrode. The reference electrode is for maintaining the stable potential on the working electrode and the auxiliary electrode is employed to prevent the reference electrode from changing its half-cell potential. The first amperometric glucose sensor is developed by Clark and Lyons in 1962 [1]. Nowadays, screen printed carbon electrode (SPCE) is widely used for detection of pathogens as it is disposable, small in size, need minute amount of sample, low cost, and portable. Many SPCE electrochemical biosensors based on the principle of amperometry have been previously developed for infectious and other foodborne pathogens [9, 24, 25].

#### **3.1.1.3.2 Impedimetric biosensor**

The impedimetric biosensor is based on the measurement of the change in the impedance of the analyte. This sensor can be constructed by immobilizing the bioreceptor on the electrode and the signal of the target can be detected by observing the impedance change over the range of frequencies. In this sensor, at low frequency, the value of the impedance increase significantly with increasing the concentration of the target which may be due to the fact that the target binds to the bioreceptor causing the hindrance in electron transfer. In contrast to the high frequency, the value of the impedance increase insignificantly with increasing the concentration of the target which is probably due to decrease in capacitive impedance [26]. Electrochemical impedance spectroscopy (EIS) incorporated with nanomaterials to detect DNA hybridization or antigen-antibody reaction for infectious pathogens or other foodborne pathogens have been previously reported [26, 27]. The integration of nanomaterials such as gold nanoparticle or carbon nanotube into electrochemical biosensor is very popular since these nanomaterials provide the large surface area which increases the binding reaction. Moreover, carbon nanotubes enhance the electric conductivity of the sensing area [27].

### **3.1.1.3.3 Conductometric biosensor**

Conductometric biosensor measures the change in electrical conductivity of the sample when the reaction between the biorecognition element and the target occurs on the sensing area. In this sensor, the electrical resistance reduces when the electrical conductance is high [28]. Using the conductive polymers such as polyaniline, polypyrrole, polyacetylene, and polythiophene as the transducer is attractive to the development of conductometric biosensor. Conductive polymer causes the electrical conductance through the electrode when the sample takes place [28]. Conductometric biosensors have been developed for detecting foodborne pathogens for biosecurity and for detecting *Mycobacterium avium* subspecies *paratuberculosis* [28, 29].

### **3.1.1.3.4 Potentiometric biosensor**

Potentiometric biosensor is monitored by measuring the potential change of the charged molecule deposits onto the electrode surface. Common potentiometric biosensor is ion sensitive field effect transistor (ISFET). This potentiometric sensor works by immobilizing the bioreceptor on the sensing surface and measures the potential change after applying the target to bind specifically to the receptor. Basically it is based on the measurement of selectively bind charged molecules on the sensing area and the potential shift is linear with the concentration of the charged molecules. Many ISFET potentiometric biosensors or ISFET modified with nanomaterials have been developed for clinical use for detecting pathogens, or for environmental monitoring [30, 31, 32].

Biosensors are classified according to the bioreceptors:

### **3.1.1.4 Enzyme-based biosensor**

This type of biosensor use enzyme as a bioreceptor to interact with the target analyte. It basically measures the rate of enzyme-catalyzed reaction and transfers the electrons to the working electrode, where the current produced can be monitored by amperometric sensor [33, 34]. The basic concept of the enzyme-based biosensor such as glucose sensor is based on the fact that the immobilized glucose

oxidase (GOx) catalyzes the oxidation of  $\beta$ -D-glucose by molecular oxygen producing gluconic acid and hydrogen peroxide [35]. Commonly used enzymes are horse radish peroxidase (HRP) and  $\beta$ -galactosidase. There are three strategies for glucose sensing: first generation is based on measuring oxygen consumption which was developed by Clark and Lyons [1], second generation is based on electron acceptors called redox mediators by transferring electrons from the enzyme to the working electrode [36], and third generation is based on direct transfer of electrons to the surface of electrode without mediators [37]. There are some limitations for enzyme-based biosensor since enzyme can be affected by temperature, pH, humidity, and limited shelf life.

#### **3.1.1.5 Antibody-based biosensor**

Antibody-based biosensor or immunosensor uses the antibody as biorecognition element to detect the specific antigen. The antibody can be monoclonal, polyclonal, and recombinant. In this sensor, the antibody is immobilized on the transducer to bind specifically to the applied antigen. When the antigen-antibody reaction occurs, the transducer collects, converts, and amplifies the signal into electrical measurable signal. The antibody can be immobilized differently such as via physical adsorption, covalent bonding, cross-linking, entrapment and encapsulation. The immunosensor can detect various targets of interest such as microorganisms, bacteria toxins, viruses, or chemicals [38, 39].

#### **3.1.1.6 Cell-based biosensor**

Cell-based biosensor uses microorganism or mammalian cell as a biorecognition element. It has the distinct advantage as it offers insight into the physiological effect of an analyte and cell has the ability to identify minute concentration of environmental agents. Whole cell-based biosensors for detecting heavy metals for the assessment of environmental toxicity, for detecting pathogens or toxins, and for pH sensing have been developed [40, 41].

#### **3.1.1.7 DNA-based biosensor**

DNA-based biosensor depends on the detection of the DNA hybridization reaction. Nucleic acid is used as a biorecognition element in this sensor.

A specific single-strand DNA probe is immobilized to bind specifically to the complementary target on the transducer surface. The electrical signal produces when the complementary target is loaded over the immobilized capture probe. DNA coils to form the double helix where hydrogen bond formed between adenine and thymine, or cytosine pairs with guanine. This process is called hybridization reaction. If there is no complementary between the capture probe and the target, no duplex and no signal will occur. The stability of hybridization reaction is based on the perfect complementary nucleotides on both strands. The double stranded DNA can be broken down by heat or high pH. However, it will re-anneal in the absence of heat or high pH. The reaction rate of the DNA hybridization can be enhanced by adding salt in hybridization buffer which will adsorb to the phosphate backbone decreases the electrostatic repulsion of the two single strands DNA. The nucleic acid-based biosensors seem to be more advantageous than antibody-based biosensors since DNA can be easily synthesized and modified with other functional group such as amino group (-NH<sub>2</sub>), thiol, biotin, and so on whereas antibody takes time to synthesize. The DNA modified with these functional groups can be easily immobilized on the sensor surface to bind to any target of interest [42]. In addition, strong hydrogen bond between nucleotides of double-stranded DNA offer specific binding as well as well control over the hybridization event and make them difficult to denature. Recently, much attention has been given to the development of nucleic acid detection in research applications as well as in clinical diagnosis. Many DNA based biosensors have been reported by many researchers [11, 13, 22, 23]. Deoxyribonucleic acid (DNA) detection is important for many diagnosis and research applications such as detection of genetic disorders, diagnosis of infectious diseases, screening of cancer related genes, and the discovery of new drugs. Hence, detection methods for specific DNA sequences are extremely important for early diagnosis. There are alternative ways to detect the DNA hybridization reaction such as traditional Southern blot, DNA microarray; however, these methods are based on radioactive, fluorescent, and enzymatic labeling which are time-consuming and complicated. Therefore, biosensors have emerged to address the obstacles mentioned and DNA sensor is one of the developments of biosensor which it uses nucleic acid as a biorecognition element. Different methods can be used to transduce this hybridization signal into measurable signal including optical methods (surface

plasmon resonance) [13, 19], mass-based transductions (microcantilever, quartz crystal microbalance) [22, 23], and electrochemical biosensors [25, 27, 32]. The schematic diagram of DNA-based biosensor is shown in Figure 3.2.

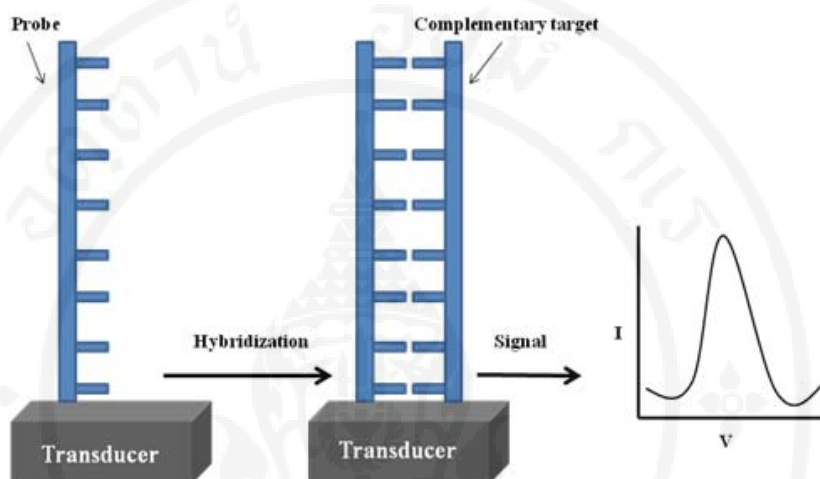

**Figure 3.2 Schematic diagram of DNA-based biosensor**

Much attention has given to the development of DNA hybridization detection based on the principle of electrochemical biosensor. Many commercialized glucose and portable DNA biosensors based on the principle of electrochemical has been reported [8, 10, 11, 24, 31]. The advantages of electrochemical biosensors over the optical biosensors are label free detection, low economical equipment cost, small in size, portable, operate well in turbid sample and so on. The disadvantage of the optic methods is the labeling step such as fluorescence, radioactive: since the fluorescent dyes (ethidium bromide, standard fluorescent dye) could be toxic and carcinogenic [43]. Even though the labeling step can enhance the sensitivity, the equipment for labeling approach based on optic biosensor is difficult to transport, is expensive, and complicated. Furthermore, the conjugation of nanomaterials such as nanoparticles, nanotube, nanowire, nanosheet with biosensors hold great promise to achieve ultrasensitive detection signal because the nanomaterials provide large surface area which increases the biomolecular recognition events on the

sensor surface, favorable electrical signal, and electrocatalytic activity. The incorporating of nanomaterials with biosensors for detection of pathogens or clinical diagnosis have been reported [9, 13, 15, 27, 32]. The electrochemical biosensor for detection of DNA hybridization can be classified according to the observed parameters such as amperometry, impedimetry, conductometry, and potentiometry. Field effect transistor is the potentiometric biosensor which is one of the techniques that can be used to detect DNA hybridization.

### **3.2 Field Effect Transistor (FET)**

Field effect transistor (FET) is a type of transistor which controls the conductivity of a channel by varying the electric field between the source and drain terminals in a semiconducting material. The current flow depends on the charge density at the semiconductor surface and the potential change. This potential change occurs due to the deposition of charged molecules on the gate sensing surface. Although there are many types of FET including MOSFET, JFET, MESFET, CNFET, ISFET, etc., ISFET is popular in biosensing applications and has been presented as the first miniaturize sensor device [44].

#### **3.2.1 Ion Sensitive Field Effect Transistor (ISFET)**

In this thesis, DNA hybridization detection by ISFET-based DNA sensor was studied and discussed.

##### **3.2.1.1 Ion sensitive field effect transistor's structure**

Ion Sensitive Field Effect Transistors (ISFET) have been increasingly developed for disease diagnosis, biological or chemical sensing and have been gained more interest as they are simple, small in size, potential for integration into a portable sensor chip, and cost effective. It is an ion sensitive device which uses for measuring the concentration of ions ( $\text{Na}^+$ ,  $\text{Cl}^-$ ,  $\text{K}^+$ ,  $\text{NH}_4^+$ , etc.) or pH in the electrolyte. The gate potential is measured when the charged molecules deposit on the gate sensing area. The current flow is directly proportional to the ion concentration in the electrolyte. The ISFET was firstly developed by Bergveld in 1970 [45] and its

concept originally derived from the structure of MOSFET. Both transistors share similar structures except the gate metal electrode in MOSFET is replaced by a sensing membrane in ISFET which exposes directly to the electrolyte. To enable the ISFET device to be functional, the reference electrode is dipped in an aqueous solution to provide a steady reference potential. The selection of the materials for the gate region is important for selectivity and sensitivity of the ISFET. Plenty of materials have been applied for the sensing membrane of the ISFET including:  $\text{Si}_3\text{N}_4$ ,  $\text{SiO}_2$  [46, 47],  $\text{Al}_2\text{O}_3$  [48],  $\text{Ta}_2\text{O}_5$  [49] etc. The  $\text{Si}_3\text{N}_4$  layer is more suitable than  $\text{SiO}_2$  layer and other inorganic oxide layers for the ISFET to be used as a sensing membrane [50]. It is because of the fast hydration of silicon oxide layer and this leads to the non linear pH response of the ISFET [51]. There are three terminals in the ISFET including: source (S) is the terminal which the major carriers go into the channel, drain (D) is the terminal which the major carriers come out of the channel and gate (G) which controls the channel conductivity. The channel between source and drain terminals is covered with the silicon oxide insulator to prevent the leakage of the current into the signal. The illustrations of the structures of MOSFET and ISFET are shown in Figure 3.3.

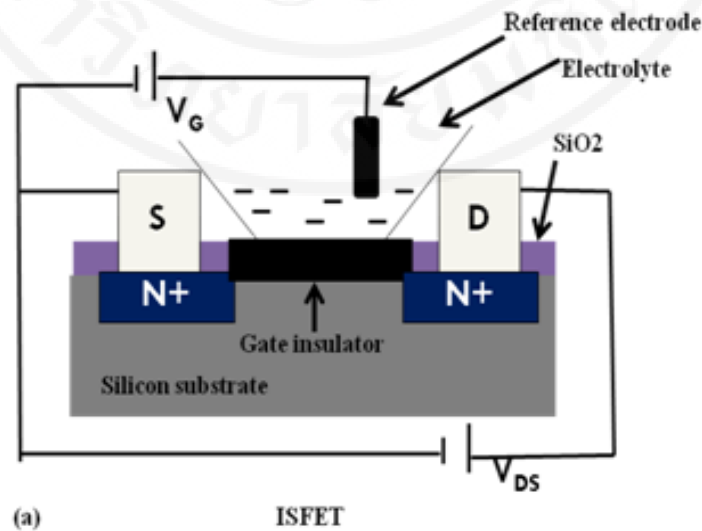

**Figure 3.3 Structures of ISFET and MOSFET (a) Schematic diagram of ISFET. (b) Schematic diagram of MOSFET.**

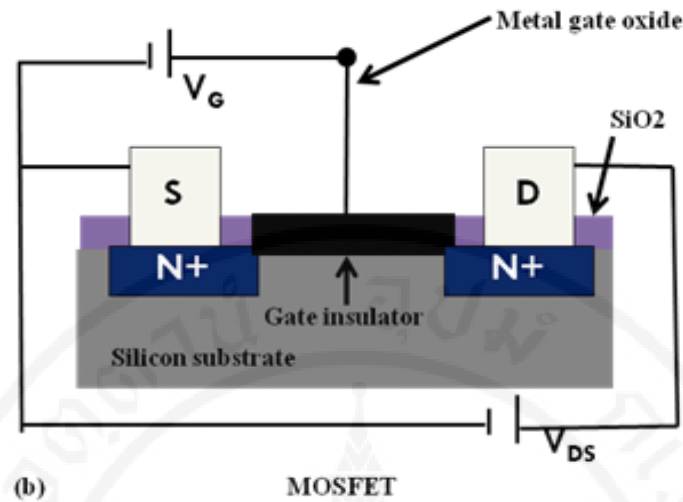

**Figure 3.3 Structures of ISFET and MOSFET (a) Schematic diagram of ISFET. (b) Schematic diagram of MOSFET. (cont.)**

### 3.2.1.2 Reference electrode

The crucial component in electrochemical transducer is the reference electrode which measures and controls the solution side potential. The function of the reference electrode is to provide the steady reference potential throughout the operation lifetime. This electrochemical biosensor converts the biological response to an electrical signal which this signal is measured as the potential provided by the reference electrode. The potential represents the energy per unit charge which transfers the charge from one side of the interface to the other. This electrode potentials results from the electrochemical activity, the redox process and this electrochemical activity can be represented by the Nernst Equation [53].

$$E^{red} = E_{red}^0 - \frac{RT}{zF} \ln \left[ \frac{a_{red}}{a_{ox}} \right] \quad (1)$$

where  $E$  is the electrode reduction potential,  $E^0_{red}$  is the standard reduction potential,  $R$  is the universal gas constant,  $T$  is the temperature in Kelvin,  $z$  is the number of electrons transferred per reaction,  $F$  is Faraday's constant, and  $a_{red}$  and  $a_{ox}$  are the chemical activity of the reduced and oxidized species, respectively.

In this study, silver/silver chloride (Ag/AgCl) reference electrode was used. The simple components of the reference electrode are silver (Ag) wire coated with silver chloride (AgCl) which immersed in a saturated filling solution, potassium chloride (3.5 M KCl) to stabilize the chloride ion concentration, all of which is enclosed in the glass tube. The structure of Ag/AgCl reference electrode is demonstrated in Figure 3.4. The environmental factors such as temperature, light, and the contaminated saturated filling solution can affect the potential of the reference electrode [52]. Moreover, there is a continuous dissolution of AgCl layer whenever the electrode operates which may affect the activity of the ions in the electrolyte leading to the changes of the electrode potential. It is because of the cathodic property of the AgCl is no longer available. Additionally, the leakage of the saturated KCl through the porous glass separator also causes the reduction of the electrode potential. These factors can affect the reference electrode stability and accuracy. The proper reference electrode must be non-polarizable and reversible, must have a high exchange current density, and so on [53]. The reaction of Ag/AgCl electrode can be represented as the following equation:

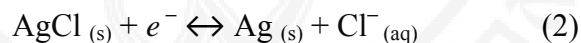

**Ag/AgCl electrode**

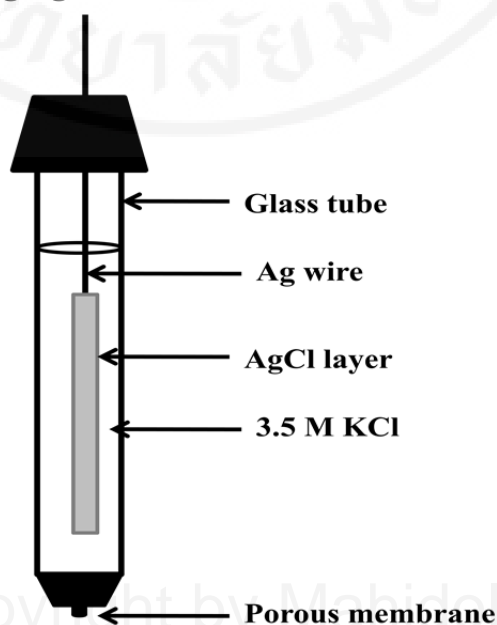

**Figure 3.4 Schematic diagram of silver/silver chloride (Ag/AgCl) reference electrode**

### 3.2.1.3 The operation principle of the ISFET

The concept of ISFET originates from the MOSFET except the metal gate oxide is replaced by the reference electrode which exposes to the aqueous electrolyte to provide the steady reference potential. The concentration of the ions in the electrolyte has an influence on the gate potential. As the ions concentration in the electrolyte changes, the gate potential changes accordingly because of the interaction of ions in the electrolyte with the sensing membrane [54]. The basic operation of the ISFET is the monitoring of the gate potential by controlling the source drain current. The potential change (voltage change) occurs when the charged molecules deposit onto the gate surface when applying an electric field. In this study, the P type silicon substrate and n-channel transistor was used. In this P type semiconductor, the major charge carriers which cause the conductive channel are positively charged holes whereas electrons are the minority charge carriers. When the positive voltage is applied to the gate, free floating electrons are pulled toward the gate insulator causing a depletion region under the gate. When the negative voltage is applied to the gate, the holes are attracted toward the gate insulator creating the accumulation region. When the further increase of positive voltage is applied to the gate, more electrons are induced toward the gate forming a conductive channel, call inversion. In the case of n type semiconductor, depletion region forms by pushing away the holes from the gate leaving the negatively charged acceptor ions. The minimum gate voltage which requires the channel to open to allow the source drain current to flow is called threshold voltage ( $V_T$ ).

### 3.2.1.4 The insulator electrolyte interface

The properties of the insulator electrolyte interface have an influence on the ISFET's sensitivity and selectivity. When  $\text{SiO}_2$  insulator surface contacts with an aqueous electrolyte, silanol groups occur and an electrochemical equilibrium with the ions in the solution ( $\text{H}^+$  and  $\text{OH}^-$ ) is happened. The hydroxyl groups at silicon oxide surface can donate the proton leaving the negatively charged surface group or accept the proton from the solution generating positively charged surface group. The illustration of protonation or deprotonation of hydroxyl groups is shown in Figure 3.5. Varying the pH will change the value of  $\text{SiO}_2$  surface potential

when the gate oxide comes in contact with the electrolyte. The charge of SiO<sub>2</sub> surface also depends on the point of zero charge itself. The point of zero charge is the pH value at which the electrical charge density on the surface is zero. The point of zero charge of SiO<sub>2</sub> surface is 2-2.5 [55]. When the pH value below the point of zero charge, the SiO<sub>2</sub> insulator surface becomes positively charged and negatively charged at pH higher than the point of zero charge. The site binding model which describes the equilibrium between the surface SiOH groups and the H<sup>+</sup> ions in the solution can be depicted as the following reactions [56]:

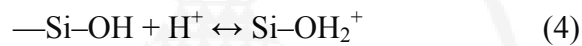
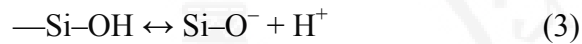

In the case of silicon nitride (Si<sub>3</sub>N<sub>4</sub>) insulator surface, the reaction between the H<sup>+</sup> ions in the solution and the binding sites of Si<sub>3</sub>N<sub>4</sub> surface such as SiOH groups and SiNH<sub>2</sub> groups are used to determine the surface potential. The reactions generate the surface potential can be described as follows:

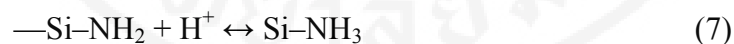
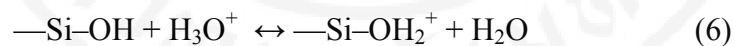
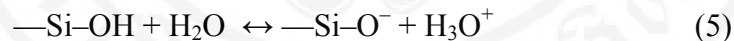

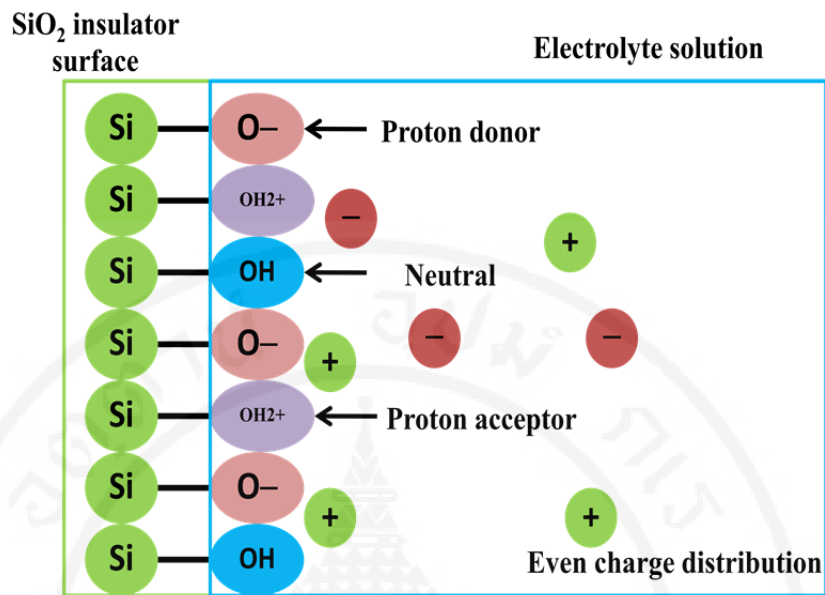

**Figure 3.5 Demonstration of the site-binding model which represents the reaction of the proton donor or proton acceptor of the hydroxyl groups**

### 3.2.1.5 PBS and pH sensitivity of ISFET

The ISFET is an ion sensitive device which used to measure the concentration of the ions or pH of the electrolyte. The ISFET was used to test with the phosphate buffer saline (PBS) in order to examine the response of the ISFET to the concentration of the electrolyte [57]. The pure PBS and the different dilution of PBS with deionized water were tested. The results indicated that the lower the concentration of the PBS, the lower the current. This was because of the fewer ions attached to the gate surface between the sensing membrane and the PBS solution and less ionic activity was detected on the gate surface. Since in the lower concentration of PBS, there is lower ionic strength in the electrolyte. This causes fewer charged molecules induce at the gate surface and lesser electrons gather at the conductive channel. These factors cause the less current to flow from source to drain. Accordingly, the electric characteristic of the ISFET is influenced by the concentration of the electrolyte [57].

As mentioned, ISFET is used for measuring ion or pH in solution. It was developed to overcome the obstacles of the pH measurement in traditional pH measuring method such as litmus papers and glass pH electrodes. Since

the traditional methods offer the disadvantages such as the chemical reaction may affect the color change in the litmus paper [58]. The fragility and the bulky of pH glass electrode make it difficult to use. It is also sensitive to the temperature higher than 60 °C [59]. The pH sensitivity of the ISFET was investigated by measuring the threshold voltage ( $V_T$ ) shift of the ISFET in the previous report [57, 60]. The results revealed that there was the linear relationship between the threshold voltage and the pH of the test buffer solution. The threshold voltage increased as the increased of the pH of the buffer solution [57, 60]. The current reduced as the acidity of the solution decreased while the current increased as the acidity in solution increased. This was due to at the higher pH, the accumulation of the negative charges,  $\text{OH}^-$  ions at the sensing membrane push electrons away from the conductive channel causing the channel resistance to increase and lowering the drain current. Contrarily, at the lower pH, the positive charges,  $\text{H}^+$  ions accumulated at the sensing membrane induce electrons at the channel, thus, leading to the reduction of the channel resistance and increasing the drain current [56, 61]. When the source drain current and voltage were set at constant, as mentioned, the threshold voltage change with the change of pH of buffer solution, and these also cause the change in the gate voltage of the device. The ISFET's sensitivity can be represented as the following equation [71]:

$$S = \frac{\nabla V_G}{\nabla \text{pH}} = \frac{\nabla V_{th}}{\nabla \text{pH}} \quad (8)$$

### **3.2.1.6 The biomolecular attachment on the gate surface of ISFET**

When the biomolecules come in contact with the gate insulator and electrolyte interface, ion permeable membrane is produced between the sensing membrane and the electrolyte. The change of the surface potential is generated by the accumulation of the charged biomolecules on the gate surface. The surface potential change is due to the occurrence of electrostatical effect between charged molecules on the gate and electrons under the gate. The charge of protein can be negative or positive depends on the pH of the test buffer solution. When the negative charge DNA is deposited onto the gate surface, electrons are pushed away to form the depletion

region under the gate causing the increasing of channel electrical resistance which reduces the drain current to flow. Therefore, the more the anions deposit on the gate, the less the flowing of drain current [60]. In order to detect DNA hybridization, the charge density change which occurs on the sensor surface or within the order of Debye length can be detected. Electrolyte solution also seems to have an influence on hybridization detection. In a high ionic strength solution, the counter ion condensation effect can decrease the hybridization detection. Hence, the low ionic strength solution is necessary for the detection to be able to be detected [62].

ISFET can be applied variety of biorecognition elements to detect the various targets of interest including: DNA [32, 64, 65], enzyme [31, 73, 74], antibody [75, 76], and cell [40, 77]. As mentioned, there are many optional ways to detect the DNA hybridization such as traditional Southern blot, DNA microarray and so on. However, there are some drawbacks. The ISFET is one of the developed techniques that used to detect DNA hybridization. Nevertheless, ISFET surface modification is needed to create an appropriate platform for DNA immobilization and detection of the target. Most of the ISFET modifications in the previous reports were based on covalent bonding via a series of chemical reactions. These methods are complex and need time to modify the surface [63]. The reactions include cleaning, activation, silanization, crosslinking, and covalent bonding of the DNA probe on the sensor surface. Firstly, the surface is cleaned with alcohol (ethanol) to remove the contaminants, and then add 3-aminopropyltriethoxysilane (APTES) to introduce an amino group on the sensor surface; next, glutaraldehyde is used as the bifunctional cross-linking agent to finish the surface modification. After that, amino modified DNA probe is immobilized on the cross-linking agent. Finally, the amino modified DNA probe immobilized on the cross-linking agent is ready for DNA hybridization detection [32, 60, 64, 65]. Schematic diagram of the surface functionalization of ISFET is illustrated in Figure 3.6.

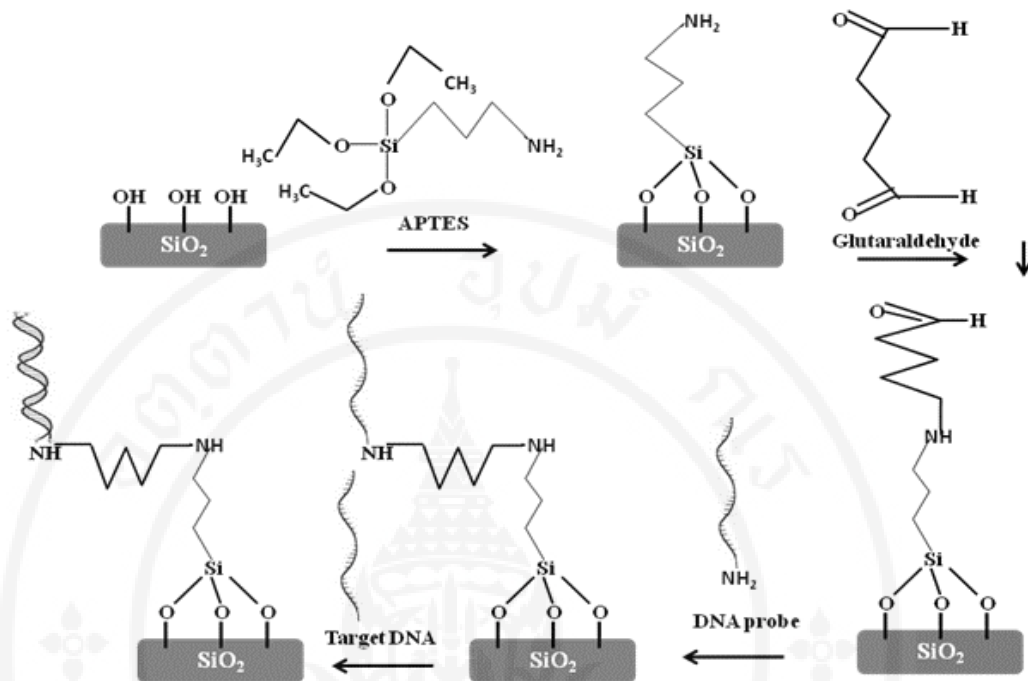

**Figure 3.6** Schematic diagram of the surface functionalization of ISFET

### 3.3 Structures, properties and applications of protein A

The protein A is generally well known protein in the field of antibody capture protein extracellular secreted by gram positive bacilli named *Staphylococcus aureus*. The molecular weight of protein A is 42 kDa consisting of five homologous immunoglobulin (Ig) binding domains, designated domains E, D, A, B, and C which fold into three-helix bundle. This protein especially binds to IgG. The main characteristic of protein A is its binding specifically to the fragment crystallizable (Fc) region of the IgG. It binds to human IgG1, IgG2, and IgG4 but not IgG3. It also binds to the fragment antigen-binding (Fab) region of human IgG, IgM, IgA, and IgE which contain the heavy chains of the V<sub>H3</sub> subfamily [66]. Furthermore, protein A is stable to a wide range of heat, pH, and it can maintain its native conformation even in the denaturing agents [67]. It also acts as the virulence factor for *Staphylococcus aureus*.

This bacterium uses protein A to prevent the phagocytic engulfment. The mutant bacterium that lacks protein A is easily phagocytosed [68].

Since protein A is a generally well known protein that has the specific binding property to the Fc region of immunoglobulin, it has been used for purification of immunoglobulin from many species of mammals. This protein can be used to detect specific antibody of bacteria or viruses by conjugation with reporter molecules such as biotin, colloidal gold, or enzymes (horseradish peroxidase (HRP), alkaline phosphatase) in immunoassays. It has been used in ELISA by conjugation with HRP to detect the antibody of hantavirus in serum of divergent mammals [79]. It has also been widely used in immunosensors for modifying the surface or for conjugation with reporter molecules to detect the target of interest. Esteban-Fernández de Ávila, et al reported detection and quantification of *Staphylococcus aureus* protein A by using magnetic beads coated with protein A and immobilized on gold screen printed electrode and *Staphylococcus aureus* protein A was detected by anti-protein A antibody immobilized over the magnetic bead coated with protein A [80]. As protein A can be adsorbed on gold surface via electrostatic force or hydrophobic interaction, it has been used to immobilize the antibody on gold surface for detection of specific antigen. Detection of carbofuran by amperometric immunosensor by immobilizing protein A onto deposited gold nanocrystal on gold electrode was reported [81]. It has also been used to detect avian influenza by immobilizing on microelectrode for specifically binding to Fc region of antibody of this virus [82].

As mentioned above, it may be concluded that protein A is one of the most employed in immunoassays. Ability of protein A to adsorb on silicon surface was characterized by atomic force microscopy measurement and X-ray photoelectron spectroscopy and its biological activity was checked by immobilization of rabbit immunoglobulin G [70]. This simple and sticky property of protein A makes it possible to modify the sensor surface for immobilizing antibody to orient antibody for effectively binding to antigen. In our laboratory, protein A was previously used to modify the ISFET surface and used as immunosensor for specifically binding to antibody to detect urinary microalbumin [83]. In this study, protein A was used to modify the ISFET surface as well, however, we aimed to use this system as DNA sensor to detect DNA hybridization. Biotinylated DNA probe was used to detect the

specific DNA target; therefore, anti-biotin antibody was coated over protein A immobilized on the ISFET surface.



## CHAPTER IV

### MATERIALS AND METHODS

#### 4.1 Materials

##### 4.1.1 Chemicals and Reagents

Protein A (PA), anti-biotin antibody, hydrogen peroxide (H<sub>2</sub>O<sub>2</sub>), concentrated sulfuric acid (H<sub>2</sub>SO<sub>4</sub>), hydrochloric acid (HCl), sodium hydroxide (NaOH), sodium chloride (NaCl), potassium chloride (KCl), phosphate dibasic (Na<sub>2</sub>HPO<sub>4</sub>), potassium phosphate monobasic (KH<sub>2</sub>PO<sub>4</sub>), ethylenediaminetetraacetic acid (EDTA) were purchased from Sigma-Aldrich. 5'biotinylated probe, synthetic complementary DNA, and synthetic non-complementary DNA targets were purchased from Invitrogen. The sequences of all oligonucleotides used in this study are listed in Table 4.1. The formula and molecular weights of the chemicals and reagents used in this study are shown in Table 4.2

**Table 4.1 Sequences of oligonucleotides used in this study**

Oligonucleotides	Sequences 5' - 3'
5'biotinylated probe	Bio-TTT TTT GAT TTC GTA TTT ACG GAA AAA GAG C
synthetic complementary DNA target	CTT TTT CCG TAA ATA CGA AAT C
synthetic non-complementary DNA target	GGC AAC GTC AAG ACT GGC AAG T

**Table 4.2** Formula and molecular weight of chemicals and reagents used in this study

Reagent and chemical name	Formula	Molecular weight
Protein A (PA)	-	45 kDa
Hydrogen peroxide	H <sub>2</sub> O <sub>2</sub>	34.01
Sulfuric acid	H <sub>2</sub> SO <sub>4</sub>	98.08
Hydrochloric acid	HCl	36.46
Sodium hydroxide	NaOH	40.00
Sodium chloride	NaCl	58.44
potassium chloride	KCl	74.55
Phosphate dibasic	Na <sub>2</sub> HPO <sub>4</sub>	142
Potassium phosphate monobasic	KH <sub>2</sub> PO <sub>4</sub>	136.09
Ethylenediaminetetraacetic acid	C <sub>10</sub> H <sub>16</sub> N <sub>2</sub> O <sub>8</sub>	292.24

#### 4.1.2 Devices and Apparatus

Ion sensitive field effect transistor was supported by Thai Microelectronic Center (TMEC). The UNI-T UT61C digital multimeter was obtained from Uni-Trend Group Limited (Hong Kong). Readout circuit and Ag/AgCl reference electrode were purchased from Winsense Co., LTD (Thailand). MP220 pH Meter was purchased from Mettler Toledo Company (Switzerland). Shaking incubator, DK-SI 020 was purchased from DAI KI Sciences Co., Ltd., Korea. Automatic pipettes (2-1000 µl) were obtained from Bio-Rad, USA.

#### 4.1.3 Reagents preparation

##### 4.1.3.1 0.1 M Phosphate Buffer Saline (PBS), pH 7

0.1 M of PBS was prepared as follow:

80g Sodium chloride (NaCl), 2g Potassium chloride (KCl), 14.4g Sodium phosphate dibasic (Na<sub>2</sub>HPO<sub>4</sub>) and 2.4g Potassium phosphate monobasic (KH<sub>2</sub>PO<sub>4</sub>) were dissolved in 900 ml of distilled water. The total volume was made up

to 1 L by adding distilled water. Then, the pH of PBS was adjusted to 7 with NaOH or HCl. Finally, the PBS was autoclaved at 121 °C for 15 min and stored at room temperature until use.

#### **4.1.3.2 10 mM of Phosphate Buffer Saline (PBS), pH 7**

One volume of 0.1 M of PBS was diluted with 9 volume of distilled water. The solution was then adjusted the pH to 7 and autoclaved at 121 °C for 15 min and stored at room temperature.

#### **4.1.3.3 1 mM of Phosphate Buffer Saline (PBS), pH 7**

One mM of PBS was made by diluting one volume of 10 mM to 9 volume of distilled water and then adjusted the pH to 7. The solution was autoclaved at 121 °C for 15 min and kept at room temperature.

#### **4.1.3.4 1 mg/ml PA**

The concentration of PA stock solution is 52 mg/ml. 1 mg/ml of PA was made by diluting 5 µl of PA stock solution into 510 µl of 1mM PBS, pH 7. Then this PA solution was stored at -20 °C.

#### **4.1.3.5 0.1 mg/ml PA**

Fifty µl of 1 mg/ml of PA was added to 450 µl of 1mM PBS, pH 7, and then this solution was kept at -20 °C until use.

#### **4.1.3.6 0.1 mg/ml of anti-biotin antibody**

The concentration of anti-biotin antibody stock solution is 1.3 mg/ml. 0.1 mg/ml of antibody was made by diluting 38.46 µl into 461.54 µl of 1 mM PBS, pH 7 to make up 500 µl total volume of antibody. Then this solution was kept at 4 °C until use.

#### **4.1.3.7 Immobilization buffer (300 mM NaCl, 20 mM Na<sub>2</sub>HPO<sub>4</sub>, 0.1 mM EDTA, pH 7.4)**

Dissolve 17.5 g NaCl, 2.8 g Na<sub>2</sub>HPO<sub>4</sub>, and 0.04g EDTA into 900 ml of distilled water. The final volume was made up to 1 L with distilled water. The buffer was adjusted the pH to 7.4 with HCl and autoclaved at 121 °C for 15 min and kept at room temperature.

#### **4.1.3.8 Hybridization buffer (150 mM NaCl, 20 mM Na<sub>2</sub>HPO<sub>4</sub>, 0.1 mM EDTA, pH 7.4)**

Dissolve 8.8g NaCl, 2.8g Na<sub>2</sub>HPO<sub>4</sub>, and 0.04g EDTA into 900 ml of distilled water. The total volume was made up to 1 L by distilled water. Then, the pH of the buffer was adjusted to 7.4 with HCl and kept at room temperature.

#### **4.1.3.9 Piranha solution**

Piranha solution was freshly prepared by diluted 10 volumes of distilled water, 3 volumes of H<sub>2</sub>SO<sub>4</sub>, and 1 volume of H<sub>2</sub>O<sub>2</sub>.

## **4.2 Methods**

### **4.2.1 Preparation methods**

#### **4.2.1.1 Preparation of ISFET sensing area**

Before modification of the surface of the ISFET, the surface was rinsed with freshly prepared piranha solution. 10 µl of freshly prepared piranha solution was placed over the surface of the ISFET for 2 minutes. Then, excess piranha solution over the surface was removed and washed with distilled water for 3 times and dried the surface at room temperature. The baseline of the ISFET was measured in the PBS.

#### 4.2.1.2 Electric measurements of ISFET

The measuring data was carried out by first joining the digital multi-meter with the readout circuit (gate potential measuring unit). All the source, drain terminal, and gate (reference electrode) were connected to the gate potential measuring unit. To obtain the gate potential, ISFET and reference electrode were immersed in 1mM PBS, pH7 and placed in the dark chamber to prevent the light that may cause effect on the sensing device. The signal of gate potential depends on the charged molecules deposit on the gate surface of the ISFET. It was measured by controlling a constant source-drain current of  $25\mu\text{A}$ . The equipments using for measuring are presented in Figure 4.1

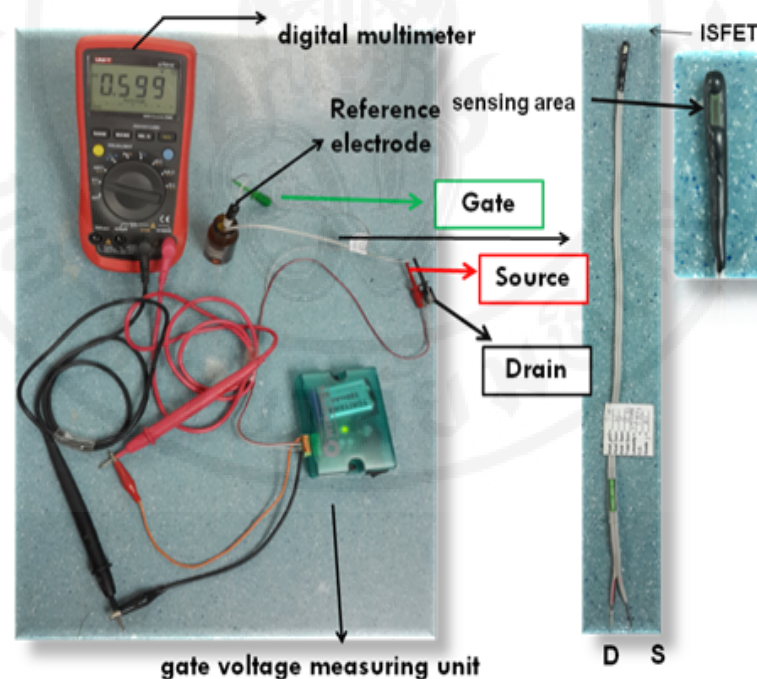
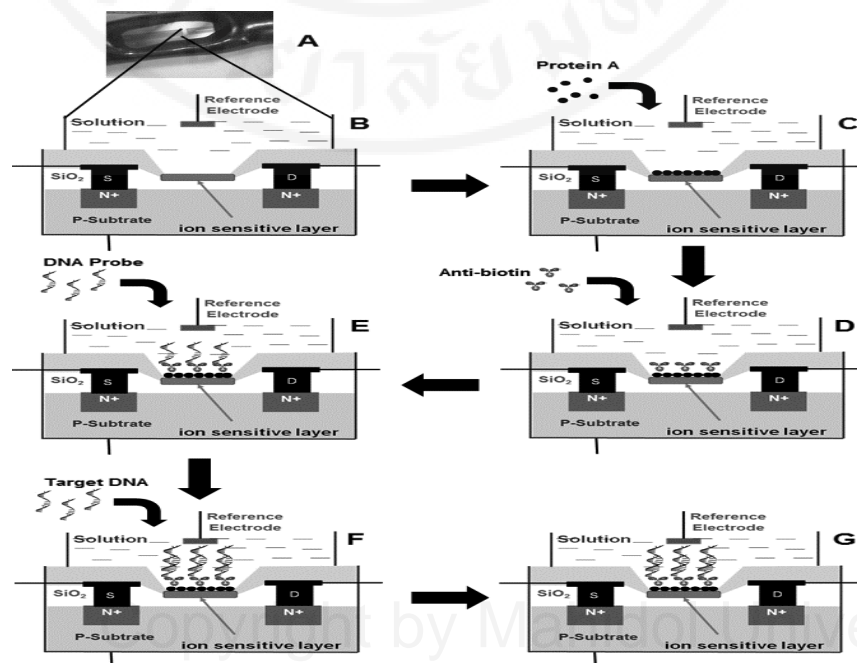

**Figure 4.1** Schematic diagram of the measuring device

#### 4.2.1.3 DNA-based ISFET sensor steps

Prior to modification, the sensing area of the ISFET was cleaned with freshly prepared piranha solution for 2 minutes to remove any organic

contaminants over it. Then, the clean surface of the ISFET was washed 3 times in distilled water again to remove the excess piranha solution and dried at room temperature. The baseline of the ISFET was measured in 1mM PBS, pH 7. The surface of the ISFET was firstly modified by 0.1 mg/ml protein A and incubated at room temperature for 1 hour. Then, 0.1 mg/ml of anti-biotin antibody was overlaid on the protein A modified ISFET surface and incubated at room temperature for 1 hour. After that, 0.5  $\mu\text{M}$  of single strand biotinylated DNA probe was immobilized over the antibody modified surface and incubated at room temperature for 1 hour. Finally, in order to test the system of the ISFET, synthetic complementary DNA target was immobilized on the biotinylated DNA probe and hybridized at 37  $^{\circ}\text{C}$  for 1 hour. In every step, after incubating the immobilized reagent, the surface was rinsed 3 times in 1mM PBS, pH 7 to remove the unbound reagents and the gate potential change was then measured. The scheme of the steps of the DNA-based ISFET sensor modification is illustrated in Figure 4.2. Before immobilization of biotinylated DNA probe and detection of complementary DNA target, the purchased synthetic probe and DNA target was dissolved and make to a concentration of 100  $\mu\text{M}$  with immobilization and hybridization buffer, respectively. Then dilute into the desire concentration when use.



**Figure 4.2** Scheme of the steps of the DNA-based ISFET sensor modification

## **4.2.2 Experiments**

### **4.2.2.1 Evaluation of ISFET quality**

Different pH buffer solutions at values 4, 7, and 10 were used to evaluate the sensitivity of the ISFET for using throughout this experiment. The quality of each ISFET was evaluated by measuring the gate potential at each pH solution. The relationship between the ion concentration in each pH solution and the gate potential of the ISFET was observed. ISFET was washed with distilled water after it was measured the gate potential in one pH solution.

### **4.2.2.2 Modification of ISFET surface**

#### **4.2.2.2.1 Optimization of Protein A Concentration**

Protein A was used to modify the surface of ISFET via physical adsorption. Six different concentrations of protein A including 0.0, 0.1, 0.25, 0.5, 1.0, and 1.5 mg/ml were used. Ten microlitres of each concentration of protein A was applied on the surface of ISFET and incubated at room temperature for 1 hour. The excess protein A then was rinsed 3 times in 1 mM PBS, pH 7 and the gate potential was measured. The gate potential change was calculated by the formula  $\Delta V = V_{PA} - V_B$  where  $V_B$  is the gate potential of baseline and  $V_{PA}$  is the gate potential after adding protein A. The lowest concentration which showed the highest potential change was the optimal concentration. Nevertheless, this concentration was not functionally tested with the antibody. Therefore, this concentration was defined as saturated concentration.

#### **4.2.2.2.2 Optimization of Anti-biotin Antibody Concentration**

To study the optimal concentration of anti-biotin antibody, various concentrations of anti-biotin antibody ranging from 0.0, 0.1, 0.25, 0.5, 1.0, and 1.3 mg/ml were chosen. Ten microlitres of each concentration of anti-biotin was immobilized over protein A modified ISFET surface via physical

adsorption and incubated at room temperature for 1 hour. Excess antibody was washed 3 times in 1 mM PBS, pH 7 and the gate voltage then was measured. The gate potential change was calculated by the formula  $\Delta V = V_{\text{Ab-biotin}} - V_{\text{PA}}$  where  $V_{\text{Ab-biotin}}$  is the gate potential of anti-biotin and  $V_{\text{PA}}$  is the gate potential of protein A. As described in the previous step, the lowest concentration of anti-biotin which displayed the highest voltage shift was defined as saturated concentration.

#### 4.2.2.2.3 Optimization of Biotinylated DNA

##### Probe Concentration

To study the optimal condition of DNA probe for detection of DNA hybridization, various concentrations of biotinylated DNA probes at 0.0, 0.1, 0.25, 0.5, 1.0, and 2.0  $\mu\text{M}$  were immobilized over the antibody via antigen-antibody reaction. Ten microlitres of each concentration of the biotinylated DNA probe was applied over the immobilized antibody on the surface of ISFET and incubated at room temperature for 1 hour. The excess probe was rinsed in 1 mM PBS, pH 7 for 3 times before measuring the gate potential. The gate voltage change was calculated by the formula  $\Delta V = V_{\text{probe}} - V_{\text{Ab-biotin}}$  where  $V_{\text{probe}}$  is the gate potential of the biotinylated DNA probe and  $V_{\text{Ab-biotin}}$  is the gate potential of anti-biotin. The lowest concentration of the biotinylated probe which showed potential peak was chosen as the optimal concentration to detect the synthetic complementary DNA target.

#### 4.2.2.2.4 Detection of Synthetic Complementary

##### DNA Target

Various concentrations of synthetic complementary DNA targets ranging from 0.0, 0.1, 0.25, 0.5, and 1.0  $\mu\text{M}$  were used to hybridize with the optimal concentration of the biotinylated DNA probe obtained from the previous step. Ten microlitres of each concentration of the target was applied over the probe immobilized ISFET surface and hybridized at 37°C for 1 hour. To evaluate the ability of the ISFET for detecting DNA hybridization, the gate potential was measured and the gate potential change was calculated by the formula  $\Delta V = V_{\text{target}} - V_{\text{probe}}$  where  $V_{\text{target}}$  is the gate potential of the synthetic complementary DNA target and  $V_{\text{probe}}$  is the gate

potential of biotinylated DNA probe. At the same time, a non-complementary target was also tested and used as a negative control.

#### 4.2.2.2.5 Detection of Non-complementary DNA

##### Target

Three different concentrations of non-complementary DNA targets at 0.25, 0.5, 1  $\mu\text{M}$  were chosen as negative controls. Ten microlitres of each concentration of non-complementary DNA was overlaid on the immobilized DNA probe and incubated at 37°C for 1 hour. Excess non-complementary DNA target was washed in 1mM PBS, pH 7 and the gate potential was measured. The gate potential change was calculated by the formula  $\Delta V = V_{\text{non target}} - V_{\text{probe}}$  where  $V_{\text{non target}}$  is the gate potential of the synthetic non-complementary DNA target and  $V_{\text{probe}}$  is the gate potential of biotinylated DNA probe.

## CHAPTER V

### RESULTS

#### 5.1 Evaluation of ISFET quality

The sensitivity of each ISFET was evaluated by measuring the gate potential of each ISFET in three different pH solutions values at 4, 7, and 10. The response of the ISFET to the ion concentrations in pH solution was observed. The results in Figure 5.1 show the linear relationship between the gate potential and various pH solutions with correlation coefficient of 0.999. The results indicated the good response of ISFET with different pH solutions. The sensitivity of the ISFET was  $47.833 \pm 1.81 \text{ mV/pH}$  which was in the range, as predicted in the previous report, of which the maximum sensitivity was  $59 \text{ mV/pH}$  [56]. Hence, the ISFETs used throughout this experiment were of good quality.

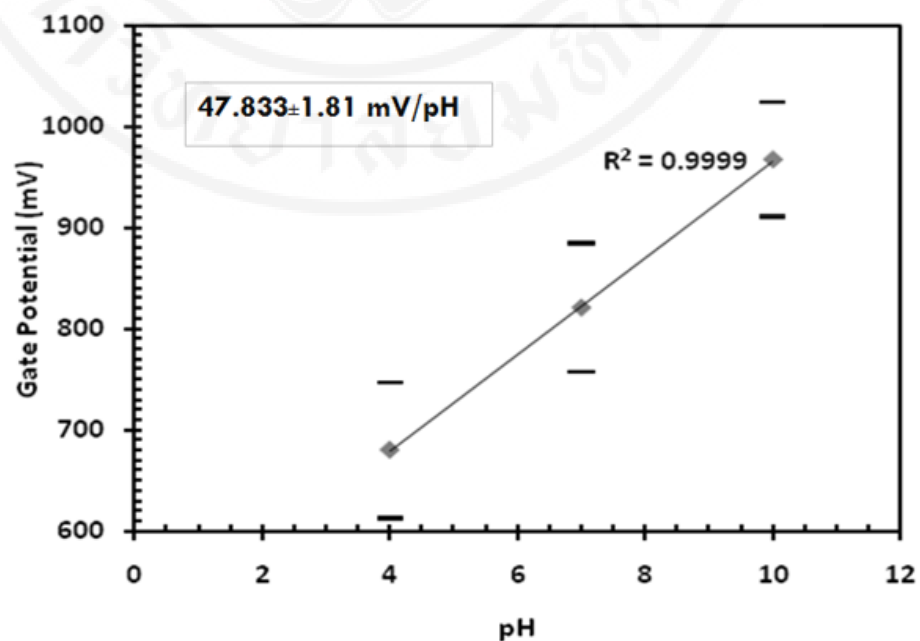
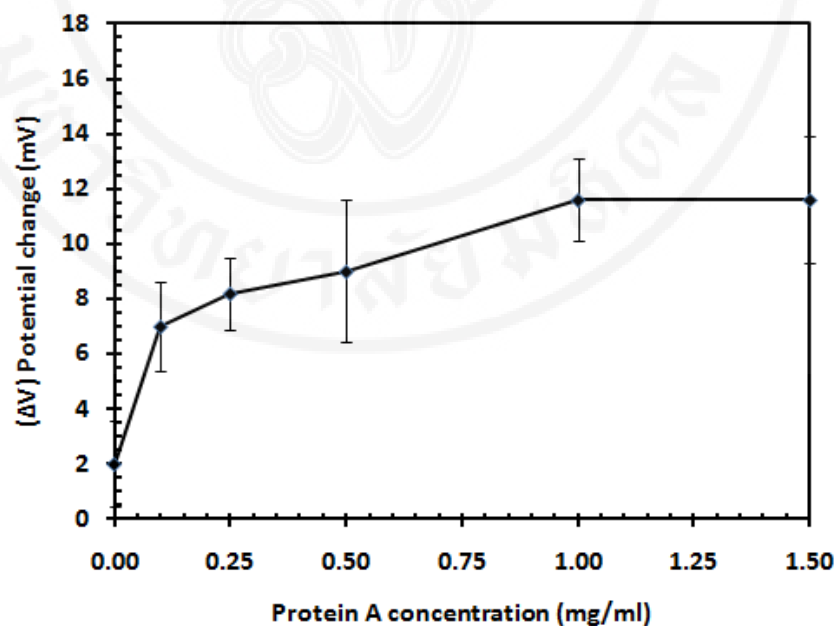

**Figure 5.1** Gate potential of ISFET response to various pH solutions. The graph represents the gate potential vs. different pH. All analyses were carried out with  $n=10$  and error bars represent  $\pm 1 \text{ SD}$ .

## 5.2 Modification of ISFET surface

### 5.2.1 Optimization of Protein A Concentration

The results of protein A at different concentrations tested are shown in Figure 5.2. The potential changes of various concentrations of protein A from 0.0, 0.1, 0.25, 0.5, 1.0, and 1.5 mg/ml were  $2 \pm 1.56$ ,  $7 \pm 1.63$ ,  $8.2 \pm 1.31$ ,  $9 \pm 2.58$ ,  $11.6 \pm 1.50$ , and  $11.6 \pm 2.31$  mV, respectively. These potential changes were calculated by the formula  $\Delta V = V_{PA} - V_B$ , the gate potential of baseline is subtracted from the gate potential of protein A. The gate potential of protein A increased as the concentration of protein A increased and saturated at 1 mg/ml. The results showed that 1 mg/ml of protein A was the saturated concentration. However, in this study, both saturated concentration (1 mg/ml) and lower concentration (0.1 mg/ml) were used to optimize the antibody in the next step as discussed in the discussion part.



**Figure 5.2 Optimization of protein A concentration.** The graph represents the average values of gate potential change vs. protein A concentrations. All analyses were carried out with  $n=10$  and error bars represent  $\pm 1SD$ .

### 5.2.2 Optimization of Anti-biotin Antibody Concentration

The results of the optimization of anti-biotin antibody with both 0.1 mg/ml and 1 mg/ml of protein A are described in Figure 5.3. At protein A 0.1 mg/ml, the potentials after adding anti-biotin shifted at  $2.8 \pm 1.13$ ,  $7.1 \pm 0.73$ ,  $8.3 \pm 2.40$ ,  $9 \pm 0.92$ ,  $10.8 \pm 1.13$ , and  $10.75 \pm 0.95$  mV at different concentration of 0.0, 0.1, 0.25, 0.5, 1.0, and 1.3 mg/ml, respectively. At protein A 1 mg/ml, the potentials after adding anti-biotin changed at  $2.9 \pm 1.1$ ,  $6.5 \pm 1.35$ ,  $8.1 \pm 1.72$ ,  $8.7 \pm 1.33$ ,  $11.2 \pm 2.57$ , and  $10.8 \pm 1.09$  mV at concentration of 0.0, 0.1, 0.25, 0.5, 1.0, and 1.3 mg/ml, respectively. These potential changes were calculated by using the gate potential of anti-biotin antibody subtracted the gate potential of protein A. The results showed that 1 mg/ml of antibody tested with both concentrations of protein A was the saturated condition. At both concentrations of protein A after adding anti-biotin, the potential changes gradually increased and were quite stable at 1 and 1.3 mg/ml which indicated the antibody was saturated and no more space left for further binding. As can be seen in Figure 5.3, the potential shifts of all concentrations of anti-biotin tested with both concentrations of protein A (0.1 mg/ml and 1 mg/ml) displayed nearly identical to each other. From this experiment, lower amount of protein A at 0.1 mg/ml appeared to be more appropriate for immobilizing on the ISFET surface and this would reduce the thickness of protein A layer. Although 1 mg/ml of antibody was the saturated condition, 0.1 mg/ml was used to study throughout this experiment to reduce the thickness on the gate surface of ISFET as discussed in the discussion part.

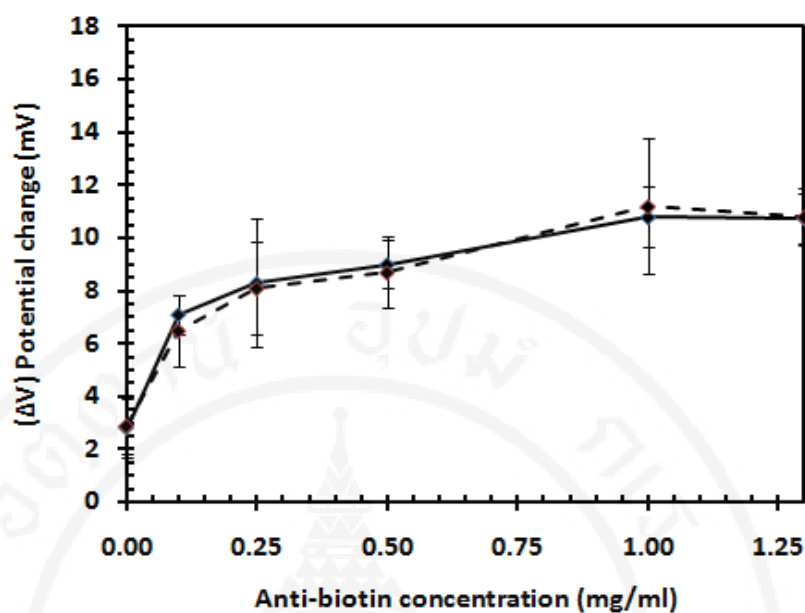
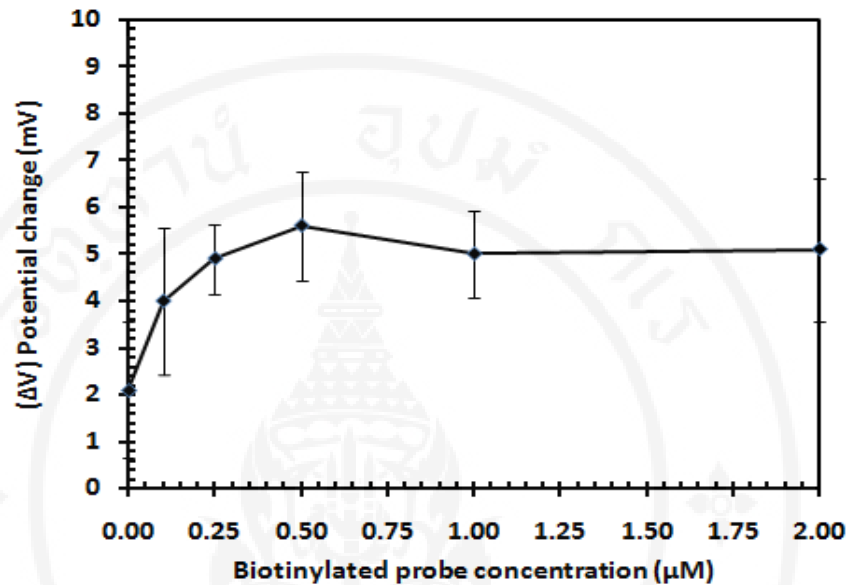

**Figure 5.3 Optimization of anti-biotin antibody concentration with both 0.1 mg/ml and 1 mg/ml of protein A.** The solid line (—) represents the potential change of anti-biotin with protein A 0.1 mg/ml and the dashed line (-----) represents the potential change of anti-biotin with protein A 1 mg/ml. The graph represents the average values of gate potential change vs. anti-biotin concentrations. All analyses were performed with  $n=10$  and error bars represent  $\pm 1SD$ .

### 5.2.3 Optimization of Biotinylated DNA Probe Concentration

The optimal condition of the biotinylated DNA probe was studied for DNA hybridization detection. The potential changes of the biotinylated DNA probe at all concentrations tested are described in Figure 5.4. The potential shifts of the biotinylated DNA probe were noticed at  $2.1 \pm 1.44$ ,  $4 \pm 1.56$ ,  $4.9 \pm 0.73$ ,  $5.6 \pm 1.17$ ,  $5 \pm 0.94$ , and  $5.1 \pm 1.52$  mV for probe concentration at 0.0, 0.1, 0.25, 0.5, 1.0, and 2.0  $\mu\text{M}$ , respectively. The potential changes were calculated by using the gate potential of biotinylated DNA probe subtracted the gate potential of anti-biotin antibody. The highest potential shift was at 0.5  $\mu\text{M}$  and started to be stable at this concentration. The potential shift did not further increase even with increased concentration which could be due to the saturation of probe binding sites. The signal shifts indicated successful

immobilization of probe. Therefore, 0.5  $\mu\text{M}$  was chosen as the optimal condition to detect DNA hybridization.

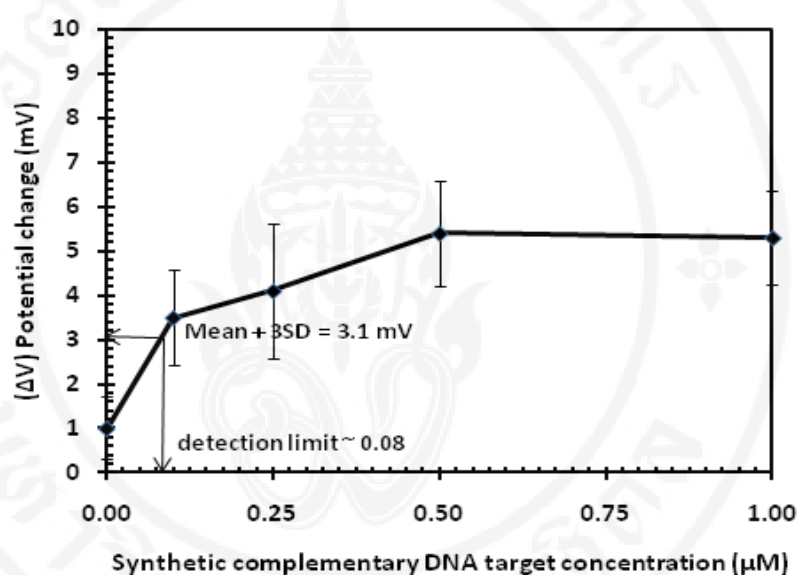

**Figure 5.4 Optimization of biotinylated probe concentration.** The graph represents the average values of gate potential change vs. biotinylated probe concentrations. All analyses were carried out with  $n=10$  and error bars represent  $\pm 1\text{SD}$ .

#### 5.2.4 Detection of Synthetic Complementary DNA Target

The signal shifts of synthetic complementary DNA target were measured by applying the synthetic complementary DNA target over the optimal condition of immobilized DNA probe obtained from 4.2.2.2.3 experiment. The results of synthetic complementary DNA target are summarized in Figure 5.5. The potential shifts of synthetic complementary DNA target were recognized at  $1\pm 0.7$ ,  $3.5\pm 1.08$ ,  $4.1\pm 1.51$ ,  $5.4\pm 1.17$ , and  $5.3\pm 1.06$  mV for DNA target concentration at 0.0, 0.1, 0.25, 0.5, and 1.0  $\mu\text{M}$ , respectively. The potential changes were calculated by using the gate potential of biotinylated DNA probe subtracted the gate potential of synthetic complementary DNA target. As can be seen in Figure 5.5, the potential changes were in upward position up to 0.5  $\mu\text{M}$  and reached nearly constant at higher concentration. The signal

shifts indicated the successful detection of DNA hybridization. According to the graph in Figure 5.5, the limit of detection (LOD) of DNA target was determined from the mean potential shift at 0  $\mu\text{M}$  (1mV) of target plus 3SD (2.1 mV) which is equal to 3.1 mV and the value extrapolated on the X-axis (synthetic complementary DNA target concentration) which is approximately at 0.08  $\mu\text{M}$  was assumed as detection limit of this method.

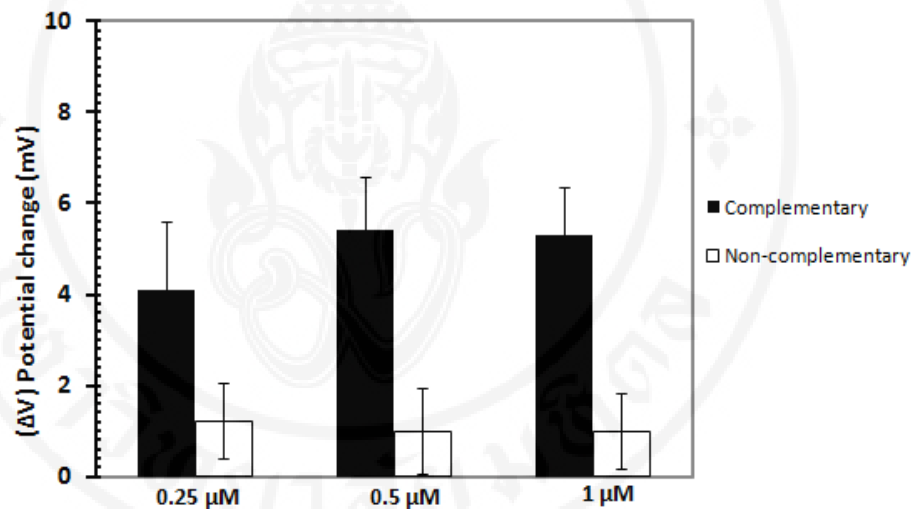

**Figure 5.5** **Detection of synthetic complementary DNA target.** The graph represents the average values of gate potential change vs. synthetic complementary DNA target concentrations. The detection limit of DNA target was determined from the mean potential shift at 0  $\mu\text{M}$  (1 mV) of target plus 3SD (2.1 mV) which is equal to 3.1 mV and the value extrapolated on the X-axis (synthetic complementary DNA target concentration) which is approximately at 0.08  $\mu\text{M}$  was assumed as detection limit. All analyses were carried out with  $n=10$  and error bars represent  $\pm 1\text{SD}$ .

### 5.2.5 Detection of Non-complementary DNA Target

To ensure that the system did not respond to the non-complementary DNA target and the signal shifts were obtained from the specific binding of complementary

DNA target, various concentrations of non-complementary DNA target ranging from 0.25, 0.5, and 1  $\mu\text{M}$  were tested as negative controls. The comparisons of potential changes between complementary and non-complementary DNA targets are demonstrated in Figure 5.6. The potential changes of all three concentrations of non-complementary DNA targets were not significantly change. The potential shifts of non-complementary DNA target were in 0-2 mV which were in the same range when tested with hybridization buffer (potential shifts at 0-2 mV). The results suggested the validity of ISFET for detection of DNA hybridization.



**Figure 5.6 Comparisons of the potential changes between complementary and non-complementary DNA targets.** The bars represent the average values of gate potential change of complementary and non-complementary DNA target. All analyses were carried out with  $n=10$  and error bars represent  $\pm 1\text{SD}$ .

## **CHAPTER VI**

### **DISCUSSION**

The developments of biosensors have gained more interest because of their sensitivity, selectivity, small in size, cost effective, and so on. Recently, most of the development of biosensors are based on the integration into microsystems. Biosensors have been developed for a wide variety of applications including: environmental monitoring, food safety, military, clinical diagnosis at the point of care system. In order to enhance the sensitivity, the integrations of the nanomaterials into biosensor approaches have been developed. The nanomaterials including: nanoparticles (gold nanoparticle), carbon nanotube, nanowire, etc. are popular because of their signal amplification due to large surface area allows more sensing space, high electrical and thermal conductivity, and great strength [9, 13, 15, 20, 32, 65]. Moreover, the developments of the nucleic acid detection techniques have gained more attention since the detection of DNA sequence is critically important for the diagnostic of inherited diseases, infectious disease, as well as cancer related genes. The detection of single nucleotide polymorphism extremely needs higher sensitivity and specificity methods. Therefore, developments for DNA detection techniques are very important for early stage treatment and monitoring.

There are traditional methods for nucleic acid detection containing Southern blot and microarray. Mostly DNA detection methods need DNA amplification in order to enhance the signal, such as polymerase chain reaction (PCR). Although these methods are sensitive, they are complex and time-consuming. Moreover, PCR equipment, reagents are high cost and it is restricted for using in the field [69]. The traditional method needs the radioactive and fluorescence labeling steps since these are the drawbacks. Ion sensitive field effect transistor (ISFET) is one of the methods that used to detect the nucleic acid. It is simple, small in size, thus, it needs small amount of sample. ISFET is a device for measuring ions or pH in the electrolyte. Its concept derived from the MOSFET except the metal gate electrode in MOSFET is

replaced by the reference electrode leaving the sensing membrane exposes to the electrolyte. The basic operation is the monitoring the gate potential by controlling the source drain current. The gate potential change is measured after depositing the charged molecules onto the gate surface and applying electric field. Many biorecognition elements can be used as bioreceptors in ISFET and it was classified as enzyme-based ISFET, DNA-based ISFET, immunosensor-based ISFET, and cell-based ISFET. In order to immobilize the biorecognition element, the surface of the ISFET needs modification step. Previously reported modification methods were based on the covalent bonding (silanization) via a series of chemical reaction which are complicated and cumbersome [63].

Therefore, the objective of this study is to develop the simple and sensitive technique based on protein A modified ISFET for detection of DNA hybridization. In this experiment, protein A was firstly immobilized on the gate surface of the ISFET to build an appropriate platform to allow an anti-biotin antibody to bind effectively. This antibody functioned as the linkage for binding specifically to the biotinylated DNA probe for detection of DNA hybridization. Antibody immobilization and maintenance of the functional formation on the solid support is important for high sensitivity detection. Therefore, to overcome the random orientation of antibody immobilization, protein A was used to immobilize the antibody to bind specifically. The technique using protein A is very advantageous as protein A can bind specifically to the Fc region of the antibody leading to the uniform orientation of antigen binding sites for effectively binding to the antigen, thus maximize the antigen binding affinity of antibody, it was also simple since both protein A and antibody were immobilized via physical adsorption and required no additional reagent, it is easy to handle when compared to complicated silanization technique. It is different from silanization technique that immobilizes the antibody in random manner thus some of them may be inhibited from binding due to steric hindrance of antigen binding domains. This modified technique could detect the DNA target without any labeling steps. In this experiment, all the concentrations of protein A, anti-biotin antibody, and biotinylated DNA probe were optimized to obtain the saturated condition for detection of DNA hybridization. Different concentrations of protein A from 0 to 1.5 mg/ml were done to study the saturation value. The gate potential changes of protein A at all

concentrations tested are shown in Figure 5.2. The saturated condition of protein A was found at 1 mg/ml and this result is similar to the previous study [84]. However, in this study, DNA hybridization occurred after modification of the surface with protein A, anti-biotin, and the probe layers. These three steps might increase the thickness on the gate surface and affect hybridization detection because the reaction might be too far from the gate surface. Therefore, not only the optimal (1 mg/ml) but also the lower (0.1 mg/ml) amounts of protein A were tested for optimization of the antibody in the next step to choose the suitable condition. Before coating protein A layer on the surface of the gate, the sensitivity of each ISFET was evaluated. The gate potential of each ISFET in three different pH values namely pH 4, pH 7, and pH 10 were measured and observed the response of the ISFET to the concentration of Hydrogen ions. The gate potential increased as the values of the pH increased as shown in Figure 5.1. The result indicates that there is a linear relationship between the gate potential and ions concentration in the pH solution. This shows the good response of ISFET with different pH solutions. The sensitivity value was  $47.833 \pm 1.81 \text{ mV/pH}$  which was in the range as predicted in the previous report of which maximum sensitivity was  $59 \text{ mV/pH}$  [56] and the sensitivity obtained is closely related with the previous reports [57, 60].

After immobilizing of protein A layer, anti-biotin antibody was immobilized over the protein A layer. The antibody was optimized over protein A at both concentrations 1 mg/ml and 0.1 mg/ml. Figure 5.3 shows the data of optimization of antibody with both concentrations of protein A. The saturated concentration of antibody at both concentrations of protein A tested was found at 1 mg/ml. As in Figure 5.3, the potential changes of all concentrations of antibody with both concentrations of protein A (1 and 0.1 mg/ml) showed nearly the same. From this experiment, lower amount of protein A (0.1 mg/ml) was more suitable to immobilize antibody. Although it was found that 1 mg/ml is the saturated condition of antibody, as discussed above in protein A, the thickness on the ISFET surface may interfere the signal detection, therefore, instead of using the saturated concentration (1 mg/ml), lower amount of anti-biotin at 0.1 mg/ml was selected for the next step. Fortunately, the potential changes could be detected after adding the biotinylated DNA probe at this lower concentration of anti-biotin. After immobilizing of protein A and antibody at 0.1

mg/ml, the biotinylated DNA probe was immobilized over the antibody layer to obtain the optimal condition for DNA hybridization detection. The results revealed that the potential change started to be stable at 0.5  $\mu\text{M}$  and did not increase with increased concentrations. Therefore, the maximal concentration of biotinylated DNA probe for DNA hybridization detection was 0.5  $\mu\text{M}$ . In order to test the system on detection of DNA hybridization, different concentrations of complementary DNA target ranges from 0 to 1  $\mu\text{M}$  were applied over the immobilized biotinylated DNA probe. The gate potential change increased up to 0.5  $\mu\text{M}$  and found to be stable at higher concentration. When compared 0.1 with 1  $\mu\text{M}$  of the synthetic DNA target, the potential changes were not proportionally increased with the elevated concentrations. This may be caused by electrostatic repulsion between DNA strands at higher concentration which might reduce hybridization event as discussed in previous study [72]. This electrostatic repulsion can be decreased by adding salt concentration in hybridization buffer. This salt absorbs to the phosphate backbone and decreases the repulsion. Stability of hybridization also depends on the melting temperature and GC content of oligonucleotides. GC pair is more stable than AT because GC pair has three hydrogen bonds while AT has two. Therefore, with increasing the GC content causing the hybridization reaction increases due to the higher melting temperature. According to the discussion in the previous study, after the DNA immobilization, the negative charge on the phosphate backbone of DNA on the sensing membrane repelled electrons away formed the depletion region. This region increased the conduction channel electrical resistance and decreased the drain current. Moreover, when the concentration of the DNA increased, the drain current further reduced [60, 72]. When the source drain current and voltage were kept at constant, the variation of the threshold voltage was influenced by the change of the concentration of deposited charge molecular on the sensing surface and thus, caused the variation on the gate potential [71]. Additionally, the non-complementary DNA targets were also tested to ensure the obtained potential changes were from specific binding with the complementary DNA targets. The potential shifts of the non-complementary DNA target were not significantly changed which were in the same range (0-2 mV) when tested with 0 concentration (hybridization buffer) of complementary DNA target. The LOD was calculated at the mean of potential change at zero concentration point plus 3

SD. This modified technique using protein A could detect the DNA hybridization at the LOD approximately at 0.08  $\mu\text{M}$ . According to the results obtained in this study, it suggested the validity of ISFET for detection of DNA hybridization and differentiation of complementary DNA from non-complementary DNA targets. This protein A modified ISFET DNA sensor can be further applied to detect the target of interest in various kinds of samples including clinical samples for detection of DNA of pathogens, gene mutation, cancer related gene and so on.

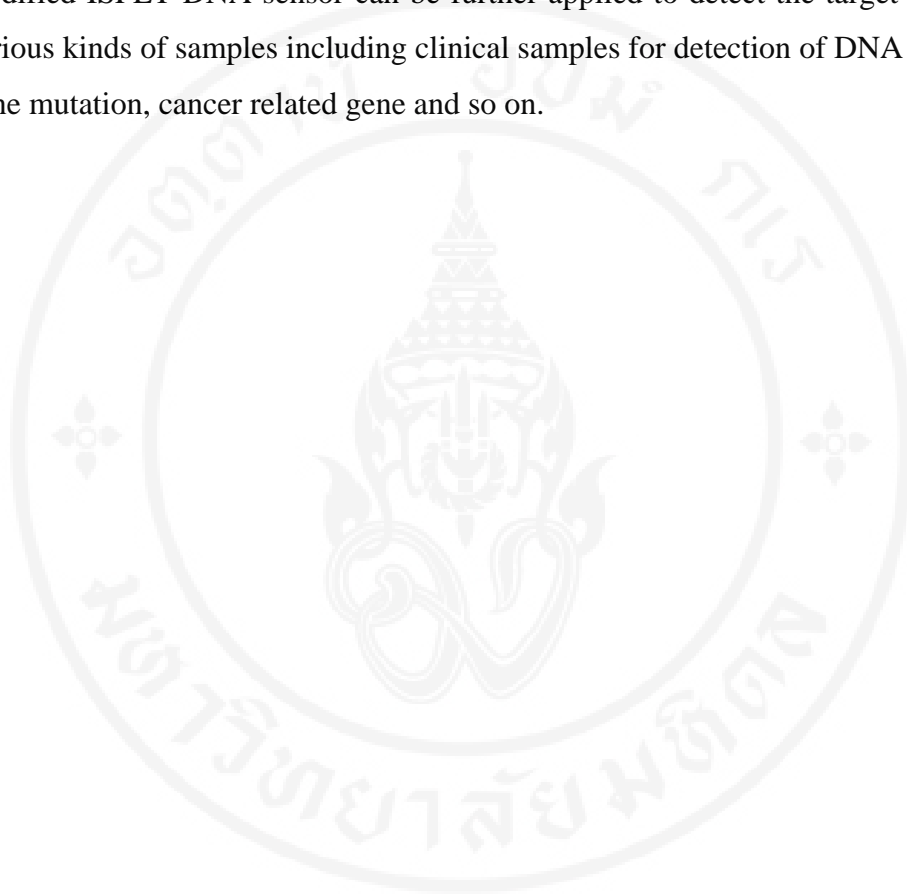

## CHAPTER VII

### CONCLUSION

DNA biosensor based on protein A modified-ISFET for detection of DNA hybridization was successfully developed with the detection limit approximately at 0.08  $\mu\text{M}$ . In this study, DNA-based ISFET sensor was carried out by modifying the sensing area of ISFET with only 0.1 mg/ml of both protein A and anti-biotin antibody, followed by immobilization of 0.5  $\mu\text{M}$  of biotinylated probe for detecting the complementary DNA target. Protein A was used to modify the ISFET surface successfully instead of the previous complicated silanization technique. The benefits of this technique over silanization are its simplicity and stickiness properties because protein A physically adsorbs to the surface of the ISFET and provides the receptors for antibody binding in highly oriented manner whereas silanization technique is complex and needs several hours to finish modification. Moreover, the system tested here could be able to clearly distinguish complementary from non-complementary DNA target. To conclude, the sensor proposed here is quite simple, sensitive and can be applied to detect various types of targets of interest from any kinds of samples.

## REFERENCES

- [1] Clark LC, Jr., Lyons C. Electrode systems for continuous monitoring in cardiovascular surgery. *Ann N Y Acad Sci.* 1962; 102: 29-45.
- [2] Malhotra BD, Chaubey A. Biosensors for clinical diagnostics industry. *Sensor Actua. B-Chem.* 2003; 91(1-3):117-27.
- [3] Yoo EH, Lee SY. Glucose biosensors: an overview of use in clinical practice. *Sensors.* 2010; 10(5):4558-76.
- [4] Xie B, Harborn U, Mecklenburg M, Danielsson B. Urea and lactate determined in 1-microL whole-blood samples with a miniaturized thermal biosensor. *Clin Chem.* 1994; 40(12):2282-7.
- [5] Xu X, Weng X, Liu A, Lin Q, Wang C, Chen W, et al. Electrochemical genosensor for detection of human mammaglobin in polymerase chain reaction amplification products of breast cancer patients. *Anal Bioanal Chem.* 2013; 405(10):3097-103.
- [6] Singh A, Poshtiban S, Evoy S. Recent advances in bacteriophage based biosensors for food-borne pathogen detection. *Sensors.* 2013; 13(2):1763-86.
- [7] Sharma H, Mutharasan R. Review of biosensors for foodborne pathogens and toxins. *Sensor Actua. B-Chem.* 2013; 183(0):535-49.
- [8] Bai S, Zhao J, Zhang Y, Huang W, Xu S, Chen H, et al. Rapid and reliable detection of 11 food-borne pathogens using thin-film biosensor chips. *Appl Microbiol Biotechnol.* 2010; 86(3):983-90.
- [9] Li Y, Cheng P, Gong J, Fang L, Deng J, Liang W, et al. Amperometric immunosensor for the detection of *Escherichia coli* O157:H7 in food specimens. *Anal Biochem.* 2012; 421(1):227-33.
- [10] Marrazza G, Chianella I, Mascini M. Disposable DNA electrochemical biosensors for environmental monitoring. *Analytica Chimica Acta.* 1999; 387(3):297-307.

- [11] Mazhabi R, Arvand M. Disposable electrochemical DNA biosensor for environmental monitoring of toxicant 2-aminoanthracene in the presence of chlorine in real samples. *J Chem Sci.* 2014; 126(4):1031-7.
- [12] Cesarino I, Moraes FC, Lanza MR, Machado SA. Electrochemical detection of carbamate pesticides in fruit and vegetables with a biosensor based on acetylcholinesterase immobilised on a composite of polyaniline-carbon nanotubes. *Food Chem.* 2012; 135(3):873-9.
- [13] Hao RZ, Song HB, Zuo GM, Yang RF, Wei HP, Wang DB, et al. DNA probe functionalized QCM biosensor based on gold nanoparticle amplification for *Bacillus anthracis* detection. *Biosens Bioelectron.* 2011; 26(8):3398-404.
- [14] Stratis-Cullum DN, Griffin GD, Mobley J, Vo-Dinh T. Intensified biochip system using chemiluminescence for the detection of *Bacillus globigii* spores. *Anal Bioanal Chem.* 2008; 391(5):1655-60.
- [15] Kell AJ, Page L, Tan S, Charlebois I, Boissinot M, Leclerc M, et al. The development of a silica nanoparticle-based label-free DNA biosensor. *Nanoscale.* 2011; 3(9):3747-54.
- [16] Bhatta D, Stadden E, Hashem E, Sparrow IJG, Emmerson GD. Multi-purpose optical biosensors for real-time detection of bacteria, viruses and toxins. *Sensor Actua. B-Chem.* 2010; 149(1):233-8.
- [17] Wong LS, Lee YH, Surif S. Whole Cell Biosensor Using *Anabaena torulosa* with Optical Transduction for Environmental Toxicity Evaluation. *Journal of Sensors.* 2013; 2013:8.
- [18] Tawil N, Sacher E, Mandeville R, Meunier M. Surface plasmon resonance detection of *E. coli* and methicillin-resistant *S. aureus* using bacteriophages. *Biosens Bioelectron.* 2012; 37(1):24-9.
- [19] Carrascosa LG, Calle A, Lechuga LM. Label-free detection of DNA mutations by SPR: application to the early detection of inherited breast cancer. *Anal Bioanal Chem.* 2009; 393(4):1173-82.
- [20] Kell AJ, Page L, Tan S, Charlebois I, Boissinot M, Leclerc M, et al. The development of a silica nanoparticle-based label-free DNA biosensor. *Nanoscale.* 2011; 3(9):3747-54.

- [21] Ittarat W, Chomean S, Sanchomphu C, Wangmaung N, Promptmas C, Ngrenngarmert W. Biosensor as a molecular malaria differential diagnosis. *Clin Chim Acta*. 2013; 419:47-51.
- [22] Chomean S, Potipitak T, Promptmas C, Ittarat W. Quartz crystal microbalance-based biosensor for the detection of alpha-thalassemia 1 (SEA deletion). *Clin Chem Lab Med*. 2010; 48(9):1247-54.
- [23] Khemthongcharoen N, Wonglumsom W, Suppat A, Jaruwongrungsee K, Tuantranont A, Promptmas C. Piezoresistive microcantilever-based DNA sensor for sensitive detection of pathogenic *Vibrio cholerae O1* in food sample. *Biosens Bioelectron*. 2015; 63: 347-53.
- [24] Lin YH, Chen SH, Chuang YC, Lu YC, Shen TY, Chang CA, et al. Disposable amperometric immunosensing strips fabricated by Au nanoparticles-modified screen-printed carbon electrodes for the detection of foodborne pathogen *Escherichia coli* O157:H7. *Biosens Bioelectron*. 2008; 23(12):1832-7.
- [25] Low KF, Chuenrangsikul K, Rijiravanich P, Surareungchai W, Chan YY. Electrochemical genosensor for specific detection of the food-borne pathogen, *Vibrio cholerae*. *World J Microbiol Biotechnol*. 2012; 28(4):1699-706.
- [26] Chowdhury AD, De A, Chaudhuri CR, Bandyopadhyay K, Sen P. Label free polyaniline based impedimetric biosensor for detection of E. coli O157:H7 Bacteria. *Sensor Actua. B-Chem*. 2012; 171–172(0):916-23.
- [27] Bonanni A, Esplandi MJ, del Valle M. Impedimetric genosensors employing COOH-modified carbon nanotube screen-printed electrodes. *Biosens Bioelectron*. 2009; 24(9):2885-91.
- [28] Okafor C, Grooms D, Alocilja E, Bolin S. Fabrication of a Novel Conductometric Biosensor for Detecting *Mycobacterium avium* subsp. paratuberculosis Antibodies. *Sensors*. 2008; 8(9):6015-25.
- [29] Muhammad-Tahir Z, Alocilja EC. A conductometric biosensor for biosecurity. *Biosens Bioelectron*. 2003; 18(5-6):813-9.

- [30] Kim HJ, Hummel JW, Birrell SJ. Evaluation of nitrate and potassium ion-selective membranes for soil macronutrient sensing. *American Society of Agricultural and Biological Engineers*. 2006; 49(3): 597-606.
- [31] Park K-Y, Choi S-B, Lee M, Sohn B-K, Choi S-Y. ISFET glucose sensor system with fast recovery characteristics by employing electrolysis. *Sensor Actua. B-Chem*. 2002; 83(1-3):90-7.
- [32] Lin C-H, Hung C-H, Hsiao C-Y, Lin H-C, Ko F-H, Yang Y-S. Poly-silicon nanowire field-effect transistor for ultrasensitive and label-free detection of pathogenic avian influenza DNA. *Biosens Bioelectron*. 2009; 24(10):3019-24.
- [33] Erden PE, Kilic E. A review of enzymatic uric acid biosensors based on amperometric detection. *Talanta*. 2013; 107: 312-23.
- [34] Cheng Y, Liu Y, Huang J, Xian Y, Zhang W, Zhang Z, et al. Rapid amperometric detection of coliforms based on MWNTs/Nafion composite film modified glass carbon electrode. *Talanta*. 2008; 75(1):167-71.
- [35] Weibel MK, Bright HJ. The glucose oxidase mechanism. Interpretation of the pH dependence. *J Biol Chem*. 1971; 246(9):2734-44.
- [36] Liu J, Wang J. A Novel Improved Design for the First-generation Glucose Biosensor. *Food technol. biotechnol*. 2001; 39(1): 55-58.
- [37] Palmisano F, Zambonin PG, Centonze D, Quinto M. A disposable, reagentless, third-generation glucose biosensor based on overoxidized poly(pyrrole)/tetrathiafulvalene-tetracyanoquinodimethane composite. *Anal Chem*. 2002; 74(23):5913-8.
- [38] Radhapyari K, Khan R. Amperometric immune-sensor for detection of toxin aflatoxin B<sub>1</sub> based on polyaniline probe modified with Mc-IgGs- $\alpha$ -AFB<sub>1</sub> antibodies. *Adv. Mat. Lett*. 2014; 5(8): 435-440.
- [39] Li Y, Hong M, Qiu B, Lin Z, Chen Y, Cai Z, et al. Highly sensitive fluorescent immunosensor for detection of influenza virus based on Ag autocatalysis. *Biosens Bioelectron*. 2014; 54:358-64.
- [40] Castellarnau M, Zine N, Bausells J, Madrid C, Juárez A, Samitier J, et al. Integrated cell positioning and cell-based ISFET biosensors. *Sensor Actua. B-Chem*. 2007; 120(2):615-20.

- [41] Singh J, Mittal SK. *Chlorella* sp. based biosensor for selective determination of mercury in presence of silver ions. *Sensor Actua. B-Chem.* 2012; 165(1):48-52.
- [42] Wang Y, Ye Z, Ying Y. New Trends in Impedimetric Biosensors for the Detection of Foodborne Pathogenic Bacteria. *Sensors.* 2012; 12(3):3449-71.
- [43] Cagnin S, Caraballo M, Guiducci C, Martini P, Ross M, Ana MS, Danley D, West T, Lanfranchi G. Overview of Electrochemical DNA Biosensors: New Approaches to Detect the Expression of Life. *Sensors.* 2009; 9:3122-3148.
- [44] Lee C-S, Kim S, Kim M. Ion-Sensitive Field-Effect Transistor for Biological Sensing. *Sensors.* 2009; 9(9):7111-31.
- [45] Bergveld P. Development of an ion-sensitive solid-state device for neurophysiological measurement. *IEEE Transaction on Biomedical Engineering.* 1970; 17(1): 70-71.
- [46] Matsuo T, Wise KD. An Integrated Field-Effect Electrode for Biopotential Recording. *Biomedical Engineering, IEEE Transactions on.* 1974; *BME-21*(6):485-7.
- [47] Bousse L, Mostarshed S, van der Schoot B, de Rooij NF. Comparison of the hysteresis of Ta<sub>2</sub>O<sub>5</sub> and Si<sub>3</sub>N<sub>4</sub> pH-sensing insulators. *Sensor Actua. B-Chem.* 1994; 17(2):157-64.
- [48] Chou J-C, Weng C-Y. Sensitivity and hysteresis effect in Al<sub>2</sub>O<sub>3</sub> gate pH-ISFET. *Mater Chem Phys.* 2001; 71(2):120-4.
- [49] Lue CE, Yu TC, Yang CM, Pijanowska DG, Lai CS. Optimization of urea-EnFET based on Ta<sub>2</sub>O<sub>5</sub> layer with post annealing. *Sensors.* 2011; 11(5):4562-71.
- [50] Abe H, Esashi M, Matsuo T. WP-B4 pH ISFET's using Al<sub>2</sub>O<sub>3</sub>, Si<sub>3</sub>N<sub>4</sub>, and SiO<sub>2</sub> gate thin films. *IEEE Transactions on Electron Devices.* 1979; 26(11):1856-1857.
- [51] Abe H, Esashi M, Matsuo T. ISFET's using inorganic gate thin films. *IEEE Transactions on Electron Devices.* 1979; 26(12):1939-44.

- [52] Ansuini FJ, Dimond JR. Factors affecting the accuracy of reference electrode. *Electrochemical device, Inc.* 1994.
- [53] Shinwari MW, Zhitomirsky D, Deen IA, Selvaganapathy PR, Deen MJ, Landheer D. Microfabricated reference electrodes and their biosensing applications. *Sensors*. 2010; 10(3):1679-715.
- [54] Jarmin R, Khuan LY, Hashim H, Sih AZM, Ghani MHBA. Simulation of ISFET Characteristics Using Constant Voltage Constant Current (CVCC) Readout Circuit. *Proceedings of the 2014 International Conference on Circuits, Systems, and Control*. 2014.
- [55] Bousse L. Single electrode potentials related to flat-band voltages measurement on EOS and MOS structures. *J Chem Phys*. 1982; 76(10): 5128–33.
- [56] Yates DE, Levine S, Healy TW. Site-binding model of the electrical doublelayer at the oxide-water interface. *Journal of the Chemical Society-Faraday Transactions 1*. 1974; 70:1807–1818.
- [57] Weng CS, Hashim U, Liu W-W. The Effect of Phosphate Buffer Solution (PBS) Concentration on the Ion Sensitive Field-Effect Transistor (ISFET) Detection. *Regional Symposium on Micro and Nanoelectronics proceeding*. 2013.
- [58] Atkins PW, Freeman WH. *Physical Chemistry*. San Fransisco, Calif, USA; 1978.
- [59] Vonau W, Guth U. pH monitoring: a review. *J Solid State Electr*. 2006; 10:746-752.
- [60] Hashim U, Chong SW, Liu W-W. Fabrication of Silicon Nitride Ion Sensitive Field-Effect Transistor for pH Measurement and DNA Immobilization/Hybridization. *J. Nano Mat*. 2013; 1-9.
- [61] Chodavarapu VP, Titus AH, Cartwright AN. CMOS ISFET microsystem for biomedical applications. *Sensors, 2005 IEEE*. 2005; 109-112.
- [62] Poghossian A, Cherstvy A, Ingebrandt S, Offenhäusser A, Schöning MJ. Possibilities and limitations of label-free detection of DNA hybridization with field-effect-based devices. *Sensor. Actuat. B-Chem*. 2005; 111–112(0):470-80.

- [63] Kamahori M, Ishige Y, Shimoda M. DNA detection by an extended-gate FET sensor with a high-frequency voltage superimposed onto a reference electrode. *Anal Sci.* 2007; 23(1):75-9.
- [64] Wenga G, Jacques E, Salaün AC, Rogel R, Pichon L, Geneste F. Step-gate polysilicon nanowires field effect transistor compatible with CMOS technology for label-free DNA biosensor. *Biosens Bioelectron.* 2013; 40(1):141-6.
- [65] Wu C-C, Ko F-H, Yang Y-S, Hsia D-L, Lee B-S, Su T-S. Label-free biosensing of a gene mutation using a silicon nanowire field-effect transistor. *Biosens Bioelectron.* 2009; 25(4):820-5.
- [66] Starovasnik MA, O'Connell MP, Fairbrother WJ, Kelley RF. Antibody variable region binding by Staphylococcal protein A: thermodynamic analysis and location of the Fv binding site on E-domain. *Protein Sci.* 1999; 8(7):1423-31.
- [67] Ohnishi S, Murata M, Hato M. Correlation between surface morphology and surface forces of protein A adsorbed on mica. *Biophysical Journal.* 1998; 74(1):455-65.
- [68] Goodyear CS, Silverman GJ. Death by a B cell superantigen: In vivo VH-targeted apoptotic supraclonal B cell deletion by a Staphylococcal Toxin. *J Exp Med.* 2003; 197(9):1125-39.
- [69] Vetrone SA, Huarng MC, Alcolija EC. Detection of non-PCR amplified *S. enteritidis* genomic DNA from food matrices using a gold-nanoparticle DNA biosensor: a proof-of-concept study. *Sensors.* 2012; 12(8):10487-99.
- [70] Coen MC, Lehmann R, Groning P, Biemann M, Galli C, Schlapbach L. Adsorption and Bioactivity of Protein A on Silicon Surfaces Studied by AFM and XPS. *Journal of colloid and interface science.* 2001; 233(2):180-9.
- [71] Loi A, Manunza I, Bonfiglio A. Flexible, organic, ion-sensitive field-effect transistor. *Applied Physics Letters.* 2005; 86.
- [72] Fritz J, Cooper EB, Gaudet S, Sorger PK, Manalis SR. Electronic detection of DNA by its intrinsic molecular charge. *Proceedings of the National Academy of Sciences.* 2002; 99(22):14142-6.

- [73] Caras S, Janata J. Field effect transistor sensitive to penicillin. *Anal Chem.* 1980; 52(12):1935-7.
- [74] Vijayalakshmi A, Tarunashree Y, Baruwati B, Manorama SV, Narayana BL, Johnson REC, et al. Enzyme field effect transistor (ENFET) for estimation of triglycerides using magnetic nanoparticles. *Biosens Bioelectron.* 2008; 23(11):1708-14.
- [75] Selvanayagam ZE, Neuzil P, Gopalakrishnakone P, Sridhar U, Singh M, Ho LC. An ISFET-based immunosensor for the detection of  $\beta$ -Bungarotoxin. *Biosens Bioelectron.* 2002; 17(9):821-6.
- [76] Zayats M, Raitman OA, Chegel VI, Kharitonov AB, Willner I. Probing antigen-antibody binding processes by impedance measurements on ion-sensitive field-effect transistor devices and complementary surface plasmon resonance analyses: development of cholera toxin sensors. *Anal Chem.* 2002; 74(18):4763-73.
- [77] Lin C-H, Hsiao C-Y, Hung C-H, Lo Y-R, Lee C-C, Su C-J, et al. Ultrasensitive detection of dopamine using a polysilicon nanowire field-effect transistor. *Chem Commun.* 2008; 30(44):5749-51.
- [78] Seo H-I, Kim C-S, Sohn B-K, Yeow T, Son M-T, Haskard M. ISFET glucose sensor based on a new principle using the electrolysis of hydrogen peroxide. *Sensor. Actuat. B-Chem.* 1997; 40(1):1-5.
- [79] Cautivo K, Schountz T, Acuna-Retamar M, Ferres M, Torres-Perez F. Rapid enzyme-linked immunosorbent assay for the detection of hantavirus-specific antibodies in divergent small mammals. *Viruses.* 2014; 6(5):2028-37.
- [80] Esteban-Fernandez de Avila B, Pedrero M, Campuzano S, Escamilla-Gomez V, Pingarron JM. Sensitive and rapid amperometric magnetoimmunosensor for the determination of *Staphylococcus aureus*. *Anal Bioanal Chem.* 2012; 403(4):917-25.
- [81] Sun X, Zhu Y, Wang X. Amperometric immunosensor based on a protein A/deposited gold nanocrystals modified electrode for carbofuran detection. *Sensors.* 2011; 11(12):11679-91.

- [82] Lin J, Wang R, Jiao P, Li Y, Liao M, Yu Y, et al. An impedance immunosensor based on low-cost microelectrodes and specific monoclonal antibodies for rapid detection of avian influenza virus H5N1 in chicken swabs. *Biosens Bioelectron.* 2014; 19(14):00724-6.
- [83] Huyen NTB. Urinary Microalbumin measurement by using antibody-modified field effect transistor biosensor. Msc thesis. Mahidol University. 2013.

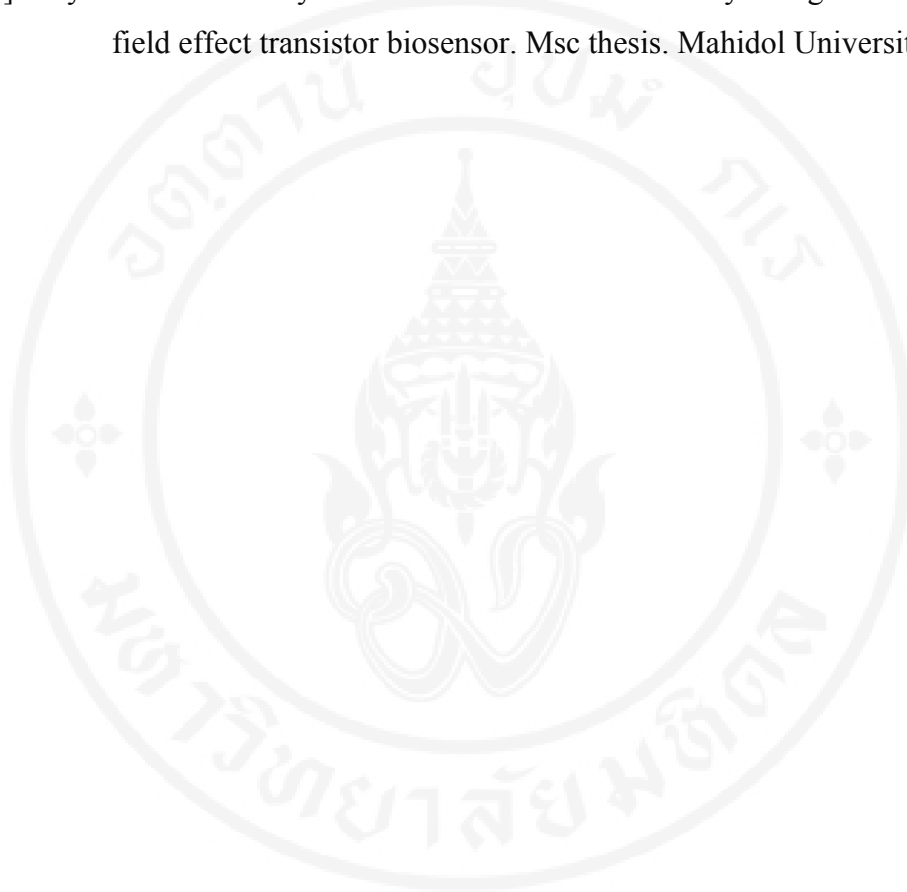

## BIOGRAPHY

**NAME** NANG MO HOM

**DATE OF BIRTH** 2 June 1990

**PLACE OF BIRTH** Mong Yang, Myanmar

**INSTITUTION ATTENDED** University of Medical Technology, Yangon  
2007-2010  
Bachelor of Medical Technology  
Mahidol University, 2012-2014  
Master of Science

**HOME ADDRESS** No. 56, 7(A), Shangone street, Myaynigone,  
Sanchaung Township, Yangon.  
Tel. +9595250518  
Email: [luvmohom@gmail.com](mailto:luvmohom@gmail.com)