

**INFLATION FORECASTING IN THAILAND USING  
ARTIFICIAL NEURAL NETWORK**



**LADAWAN KHONGDAMNERN**

**A THEMATIC PAPER SUBMITTED IN PARTIAL  
FULFILLMENT OF THE REQUIREMENTS FOR  
THE DEGREE OF MASTER OF BUSINESS ADMINISTRATION  
(BUSINESS MODELING AND ANALYSIS)  
FACULTY OF GRADUATE STUDIES  
MAHIDOL UNIVERSITY**

**2010**

**COPY RIGHT OF MAHIDOL UNIVERSITY**

Thematic Paper  
entitled  
**INFLATION FORECASTING IN THAILAND USING  
ARTIFICIAL NEURAL NETWORK**

.....  
Miss Ladawan Khongdamnern  
Candidate

.....  
Lect. Pandej Chintrakan, Ph.D.  
Major advisor

.....  
Lect. Chairawee Anamthawat-Kierig,  
Ph.D.  
Co-advisor

.....  
Prof. Banchong Mahaisavariya,  
M.D., Dip Thai Board of Orthopedics  
Dean  
Faculty of Graduate Studies  
Mahidol University

.....  
Asst. Prof. Yingyot Chiaravutthi, Ph.D.  
Program Director  
Master of Business Administration  
Program in Business Modeling and  
Analysis  
International College  
Mahidol University

Thematic Paper  
entitled  
**INFLATION FORECASTING IN THAILAND USING  
ARTIFICIAL NEURAL NETWORK**

was submitted to the Faculty of Graduate Studies, Mahidol University  
for the degree of the Master of Business Administration (Business Modeling and  
Analysis)

on  
August 28, 2010

.....  
Miss Ladawan Khongdamnern  
Candidate

.....  
Asst. Prof. Sittisak Leelahanon, Ph.D.  
Chair

.....  
Lect. Chairawee Anamthawat-Kierig,  
Ph.D.  
Member

.....  
Lect. Pandej Chintrakan, Ph.D.  
Member

.....  
Prof. Banchong Mahaisavariya,  
M.D., Dip Thai Board of Orthopedics  
Dean  
Faculty of Graduate Studies  
Mahidol University

.....  
Assoc. Prof. Rassamidara Hoonsawat,  
Ph.D.  
Dean  
International College  
Mahidol University

## ACKNOWLEDGEMENTS

First and Foremost, I would like to thank my advisor, Dr. Pandej Chintrakan for providing valuable topic, guidance on the first thematic written and example of related topic of my thematic.

Second, I would like to thank Pongsak Srithongnopawong for educating me on the Artificial Neural Network and provide valuable knowledge for the experiments and thematic written.

Third, I would like to thank Phornlerd Suthikiat for educating me on the Artificial Neural Network, providing valuable knowledge for the experiments and thematic writing and giving technique to execute the ANN model.

Forth, I would like to thank Dr. Ornlatcha Sivarak for being supportive in any questions related to thematic paper. She also provided much valuable guidance.

Lastly, I would like to thank officers at Ministry of Commerce and Bank of Thailand for providing secondary CPI and Inflation data and precious documentation on how the data is originated and being used.

The success of this thematic paper cannot be succeeded with attentive support from mentioned above. Last but not least, my honorable mention goes to my family and friends for their understanding and supports.

Ladawan Khongdamnern

INFLATION FORECASTING IN THAILAND USING ARTIFICIAL NEURAL NETWORK

LADAWAN KHONGDAMNERN 5038664 ICMA/M

M.B.A. (BUSINESS MODELING AND ANALYSIS)

THEMATIC PAPER ADVISORY COMMITTEE: PANDEJ CHINTRAKAN, Ph. D.,

CHAIRAWEE ANAMTHAWAT-KIERIG, Ph. D.

ABSTRACT

The purpose of this thematic paper is to build a forecasting Consumer Pricing Index and inflation model using an Artificial Intelligence Neural Network (ANN) to predict inflation rates. The key objective is to predict only inflation rates, an exceptional the inflation rate having a direct relationship to the consumer pricing index, by calculating the percentage change of the consumer pricing index. Therefore, the thematic paper captured the prediction through CPI forecasting and through the Inflation forecasting by associating both ANN and Autoregressive order with 2 degrees of freedom (Autoregressive (2)). There have been ten models constructed to forecast the inflation rate of Thailand based on two types of inflation; headline and core. Since headline inflation is more sensitive to changes in the world economy, oil prices and raw food, it is more oscillated than core inflation. As expected, ANN is able to handle more fluctuated situations than building from the normal process of Autoregressive modeling (2). The data was analyzed and the conclusion is that ANN performed better in finding non-linear or non-pattern inflation statistics than Autoregressive (2) model.

KEY WORDS: ARTIFICIAL NEURAL NETWORK/ FORECASTING/  
INFLATION/ CONSUMER PRICING INDEX/ CPI

45 pages

การคาดการณ์เงินเฟ้อโดยใช้โครงข่ายประสาทเทียม

INFLATION FORECASTING IN THAILAND USING ARTIFICIAL NEURAL NETWORK

ลดาวัลย์ คงคำเนิน 5038664 ICMA/M

บธ.ม. (การวิเคราะห์และการสร้างตัวแบบธุรกิจ)

คณะกรรมการที่ปรึกษาสารนิพนธ์: ปานเดช ชินตระกูล, Ph.D., ฉายรวี อนามธวัช – คีริก, Ph. D.

#### บทคัดย่อ

สารนิพนธ์ฉบับนี้มีจุดมุ่งหมายเพื่อศึกษาการสร้างโครงข่ายประสาทเทียมเพื่อพยากรณ์อัตราเงินเฟ้อสำหรับประเทศไทย จากตัวแบบการคาดการณ์ดัชนีผู้บริโภคและเงินเฟ้อโดยมีวัตถุประสงค์หลักในการทำนายเพียงอัตราเงินเฟ้อใน นอกเสียแต่ว่าอัตราเงินเฟ้อมีความแปรผันตรงกับดัชนีผู้บริโภค การทำนายนี้จึงกระทำโดยการคำนวณอัตราการเปลี่ยนแปลงของดัชนีผู้บริโภค และอัตราเงินเฟ้อ การศึกษานี้ได้สร้างการทำนายดัชนีผู้บริโภคโดยการประยุกต์ใช้โครงข่ายประสาทเทียมและระเบียบวิธีการถดถอยอัตโนมัติ จากอดีตถึงปัจจุบันได้มีการสร้างตัวแบบลักษณะนี้ในรูปแบบเพื่อใช้ในการคาดการณ์อัตราเงินเฟ้อในประเทศไทย เป็นสองกรณีกล่าวคือ กรณีหัวเรื่อง และ แก่น เนื่องจากอัตราเงินเฟ้อเสดไลน์มีความอ่อนไหวต่อการเปลี่ยนแปลงทางเศรษฐกิจและสินค้าโภคภัณฑ์เช่นน้ำมัน และ วัตถุดิบอาหาร ดังนั้นอัตราเงินเฟ้อชนิดนี้จึงมีความผันผวนมากกว่ากรณีแก่น และจากการตระหนักว่าโครงข่ายประสาทเทียมมีความสามารถในการจัดการกับการผันผวนมากกว่าระเบียบวิธีการถดถอยแบบอัตโนมัติ ดังนั้นข้อมูลได้ถูกวิเคราะห์และได้ผลยืนยันว่าโครงข่ายประสาทเทียมมีความสามารถในการแสดงผลดีกว่าในการค้นหารูปแบบความไม่เชิงเส้นของสถิติดัชนีผู้บริโภค

45 หน้า

## CONTENTS

	<b>Page</b>
<b>ACKNOWLEDGEMENTS</b>	<b>iii</b>
<b>ABSTRACT (ENGLISH)</b>	<b>iv</b>
<b>ABSTRACT (THAI)</b>	<b>v</b>
<b>LIST OF TABLES</b>	<b>vii</b>
<b>LIST OF FIGURES</b>	<b>viii</b>
<b>CHAPTER I INTRODUCTION</b>	<b>1</b>
<b>CHAPTER II LITERATURE REVIEW</b>	<b>6</b>
<b>CHAPTER III RESEARCH AND METHODOLOGY</b>	<b>17</b>
<b>CHAPTER IV EMPIRICAL RESULTS</b>	<b>25</b>
<b>CHAPTER V CONCLUSION</b>	<b>33</b>
<b>REFERENCES</b>	<b>36</b>
<b>APPENDICES</b>	
Appendix A: Results of Inflation Forecasting based on forecasting of CPI using ANN result	39
Appendix B: Results of Core CPI Forecasting	40
Appendix C: Results of Core Inflation Forecasting result	41
Appendix D: Results of Headline Inflation Forecasting based on forecasting of CPI using ANN	42
Appendix E: Results of Headline CPI Forecasting	43
Appendix F: Results of Headline Inflation Forecasting	44
<b>BIOGRAPHY</b>	<b>45</b>

## LIST OF TABLES

<b>Table</b>	<b>Page</b>
2.1 Types of Transfer Function	10
4.1 Default Parameters of ANN Topologies	27
4.2 Autoregressive (2) Parameters	29
4.3 Performance summary of twelve models	30
4.4 Performance on Forecasting Inflation	32
5.1 Performance summary of twelve models	34

## LIST OF FIGURES

<b>Figure</b>	<b>Page</b>
2.1 Structure of ANN Model	9
2.2 Single Input Neuron	11
2.3 Multiple Input Neurons	12
2.4 Single Layer of Neuron	12
2.5 Multi Layers of Neuron	13
2.6 Recurrent Network	13
3.1 Data Flow Diagram of Inflation Forecasting System	18
3.2 (1) Two lagged CPI used to predicted CPI (2) Two lagged Inflation rate used to predicted Inflation rate	20
4.1 Neural Network Model captured from MATLAB	28
4.2 Factor affects of instable of CPI	31
4.3 Methodologies constructed for inflation forecasting	31

## **CHAPTER I**

### **INTRODUCTION**

#### **1.1 Background of Study**

Obtaining superior forecasting information on macroeconomic indicators has attracted the attention of many policy makers and business people as well as academics over the past decades. As a consequence, there are a number of forecasting models available for researchers to formulate and measure their forecasting performance on variables such as; stock prices, GDP percentage growth, the currency exchange rate, gold prices, oil prices, the consumer pricing index, inflation, etc. This research builds a model to forecast the consumer pricing index and inflation in Thailand. There are two main approaches to the forecasting. The traditional approach is commonly used by statisticians involving a statistically model, such as Bayesian, Autoregressive, ARIMA, etc. A recent tactic is the technical approach, which involves computerization to predict the pattern of the data, i.e. the artificial neural network (ANN).

##### **1.1.1 Consumer Pricing Index versus Inflation Rate**

The consumer pricing index (CPI) in Thailand is reported by the Thai Ministry of Commerce. It is an indicator estimated from the average price of consumer goods and services at one period compared to a base year, having an index equivalent to a hundred items. The base year for this study is 2007 and consumer goods and services include food, drink, entertainment services, transportation, communication, medical care, raw food, the oil price index, etc. The Ministry of Commerce has chosen the “Laspeyres Index” as a formula to calculate the Thai CPI, which compares the price change over base period (year 2007). The benefits of the CPI are: to measure the inflation rate, measure the cost of living, measure the minimum rate and measure the Gross Domestic Product.

Whereas, the inflation rate in Thailand is derived from the percentage change of the CPI of the current period comparing it to the same period of the previous year. It can be reported on a monthly, quarterly or annual basis as all use the same source of CPI in the calculation. In other words, the inflation rate is the same as the CPI but reported in units of percentage. Therefore, by choosing to forecast inflation upon the forecasting of the CPI would be more dynamic in terms of reporting and it is more straightforward.

There are two types of CPI obtainable in Thailand: core and headline. Both types use the same formula as the Laspeyres Index. The only distinct difference is the calculation that is included or not included the intense fluctuated indices. The fluctuated indices are the oil price and raw food. The core CPI excludes the fluctuated indices, whereas the headline CPI includes fluctuated indices. Therefore, the headline CPI is more fluctuated than the core CPI. This study captures and compares the differences on the same forecasting technique of core and headline inflation. The study is to validate the artificial neural network model for their different patterns of data arrangement.

### **1.1.2 Reasons for Choosing the Artificial Neural Network for the Study**

This study has chosen to forecast the inflation rate of Thailand by associating the artificial neural network paradigm. The neural network is one of the Artificial Intelligence approaches, which nowadays is believed to be one of the most popular tools to estimate most of the macroeconomics data. The artificial neural network (ANN) paradigm is inspired by the way the human brain functions. The important constituent of the ANN model is the information processing system that can be assembled from an input data set. ANN learns from past experience or historical data inputted into the system, and process the pattern of the observation to find potential assessment. For example, a human can learn how to write a number 5 by seeing and copying the pattern into a handwritten shape. Even though, each person constructs a number 5 differently, but it is likely all will be comprehended. As the

prototype is the same as it has small straight line on top, vertical line connected on the left and at the bottom of vertical line, inverse “c” is connected.

### **1.1.3 Advantages and Disadvantages of Artificial Neural Network**

There are many advantages of ANN over other models. ANN can be trained from any kind of inputs to develop a transfer function or its intelligence. This feature is suitable for any non-linear manipulation. Another distinctive characteristic of ANN is competence in noise barring, which mean it has ability to handle deficient data sets. Nevertheless, its disadvantages have not failed to be noticed by researchers, such as over-fitting and over-saturation on data examined by ANN. Over-fitting or over-saturation occurs when a training algorithm is ended before a local minimum is reached (Nakamura, 2005). However, there is a technique to overcome these disadvantages; researchers applied data preprocessing as to re-group, rearrange the input data in a more appropriately way, a technique which will be mentioned in detail in Chapter 3. Another disadvantage is: ANN does not illustrate its intelligence into the functional form. Still, it is believed to be an inclusive and precise model for financial statistics (Kaastra and Boyd, 1995).

In conclusion to this section, this research uses the ANN paradigm to forecast Thailand's consumer pricing index to forecast the Thailand inflation rate. Thailand uses a consumer pricing index (CPI) to calculate the inflation rate, and hence CPI can be referred to as inflation. The consumer pricing index is obtained from the Ministry of Commerce on a monthly basis, categorized into two types; headline and core. Maximum existence of data as of researching time would be acquired, i.e. Headline CPI from January 1976 to December 2009 and core CPI from January 1985 to December 2009. Headline CPI includes a fresh food index and energy index to its calculation upon core CPI. As energy and fresh food fluctuate more than other indices, headline CPI is deliberated to be more varied. To measure ANN performance, the study uses an autoregressive model to evaluate its results, and the unit measurement is mean square error or MSE.

## **1.2 Significance of study**

The rate of inflation has often been reported to show the direction of the country's financial health. It is well known as a measuring unit of the value of the money at any current period, it can be more or less depending on the inflation rate. During recession, people reduce spending on products until prices fall, referred to as deflation. Inflation would imply that money has less value, or require more money to spend on the same product. Whereas, deflation means that value of money is augmented. Deflation and inflation are the same in terms of calculation, where deflation is negatively reported and inflation is positively reported. Knowing how to analyze inflation is extremely vital. Governments often use current and forecasted inflation to launch a new policy to handle an economic situation. Inflation has also defined monetary direction, such as increasing and decreasing the money supply of the country. Foreign investors use inflation rates to foresee their investment, measure their risk and expected return. Consequently, an artificial neural network can assist in finding more accurate future inflation to leverage the country's risk.

## **1.3 Objective of the Study**

The objective of the research is first to build forecasting consumer pricing index and inflation models using Artificial Intelligence neural networks to predict inflation rates. Secondly, to utilize existing autoregressive models to process the forecasting. Lastly, evaluation of the performance of each model is using a mean square error technique.

## **1.4 Scope of the Study**

Both types of consumer pricing indexes are obtained from the Ministry of Commerce; headline and core. As mentioned, headline CPI includes a raw food index and an energy index for the calculation which fluctuates more than core CPI. Headline CPI from January 1976 to December 2009 and core CPI from January 1985 to December 2009. Two models are associated; Artificial Intelligence neural network

and autoregressive. Back propagation feed forward technique with Levenberg-Marquardt training algorithm is used for ANN. Autoregressive model engaged second degree of freedom, since predicted value based on two lagged periods (further discussed in Chapter 3), known as AR(2). MATLAB application is used to build both models for this study.

### **1.5 Benefits**

Thailand's inflation rate is calculated from only one source, which is the consumer pricing index. By forecasting CPI to the most accurate or having smallest MSE would be of benefit to the country. As mentioned earlier, inflation is an important indicator of the country's economic health as inflation forecasting helps the country to manage its monetary system. If successful in finding conditions of using a neural network, this methodology will greatly benefit the country to forecast inflation more accurately. Inflation data is not constructed in linearly pattern; ANN will observe and find the matching pattern for Thai inflation data.

## **CHAPTER II**

### **LITERATURE REVIEW**

#### **2.1 Introduction**

There are many techniques applicable for inflation forecasting, they have been proved and described differing results in many papers. Even though using the same model to forecast with the same type of information, but inputs come from different sources, i.e. inflation rates or consumer pricing indices from different countries, results are distinctive. Some studies have been chosen to apply to the forecasting model repetitively because of the accurate or close results of forecasting data to the existing data. While unpopular researches are often brought to further study or extending existing research, and become successful and widely accepted later on. Therefore, this study associates with both well known and newly introduced methodologies which are the autoregressive model and neural network respectively. This section is pooled from existing studies and classifies them into type approaches; traditional and neural network.

#### **2.2 Traditional Econometric Approach or Human Intelligence**

The traditional approach or human intelligence comes from the approach of using formulas built from understanding human responses over many years. Many existing principles are presented and are being used for newer studies. The traditional approach is through having valid formulae, which can be statistical formulas, econometric techniques, regression formulas, multiple regression models etc. For example, a regression formula seeks patterns of input data and finding parameters of variables for equations. Nonetheless, regression formulas only support linear patterns. If a data pattern is not linear, regression will not be suitable. Therefore, each group of data requires different kinds of formulas. The more data input and more

variance, the easier to find the equation for prototypes. For inflation forecasting techniques would be varied depending on the pattern of historical information kept in each country. Even in the same country, the formulas can be more than one type for inflation forecasting.

There are many factors that can cause the calculation of inflation rates to be uncertain, depending on the time period. Recession can cause inflation rates to be low, since consumers will spend less money on consumer goods, which is used as a main indicator to calculate consumer pricing index or the inflation rate. The government also obtains main indicators that affect economics of the country to apply to the calculation, and most of the time it is not in the same pattern, i.e. not always going up or not always going down. It can increase for current period, and decrease over the next two periods.

Ippei Fugiwara and Maiko Koga (2002) is one example that chose econometric Statistic Forecasting Method (SFM) to predict inflation in Japan. This technique is associated with time series data, which was believed to be uncertain. The study collected historical inflation rates in time series to study the trend of inflation rates. The SFM is very generic, where this paper is distinct from others on the processes to construct a model to capture uncertainty. It was first started with building large observations of the vector autoregressive (VAR) forecasting model and then re-arranges the outputs into more uniform patterns, which is similar to ANN's data preprocessing step. VAR forecasting of Hamilton (1995) is shown that it is a forecasting tool that applies from multiple time series of data. Affected variables can also be applied to the VAR model, but researchers need to ensure those variables are stationary for the model by applying other methods, such as evaluating using F-Statistic. The difficulty arises with this technique when one wants to find which variables should affect the forecasting model and which do not. Moreover, researchers are required to have economic and financial knowledge to judge if the variables inputted to the model are enough. It is a very good forecasting model if we can define the exact variables for it.

Other inflation forecasting technique being researched by Cagas et al. (2006) are the automatic leading indicator (ALI) and the econometric structural model (ESM), which are believed to be competent in working with uncertain data.

ALI is also used on other macroeconomic forecasting, such as GDP growth forecasting researched by Gonzalo, Kapetanios, Smith and Weale (1999). It chose the factors that are analyzed to affect the growth of GDP. Similarly Cagas et al. (2006), found the factors affecting inflation trends. The angle of each research is dependent on the variable selected. The ALI model has also proved to perform better than the VAR model in terms of giving forecasting data close to the presented data by Banerjee et al. (2003). Neither techniques (VAR and ALI) will result in best performance if variables inputted are not stationary and not related to the model.

Dynamic model averaging by Koop and Korobilis (2009) proved to be another sustainable approach of coping with inflation changes over time by comparing the results with recursive ordinary least square (OLS) forecasts. The name of the model is already defined that the model can be changed to fit certain groups of data. Since the inflation rate is stable in one year and falling dramatically the next year, the study can adjust the model to either marginal affect or affect the whole model. Inflation rates change over time due to both internal and external factors. Thus, dynamic model averaging is eliminating the differences between coefficient and actual data. However, the data of each certain period might not be varied enough to find accurate marginal effects. While an ordinary least square model is predicted historical inflation regard list of dramatically change of data. It focuses on the pattern of the whole set of data, and marginal effects do not change over time as in a dynamic model averaging. The paper has proven that the dynamic model averaging approach has better forecasting performance than ordinary least approach.

The final framework is the autoregressive (AR) model, which is a predicted model by using previous input data to forecast current output data. Previous input data can be lagged back more than one period. The more lagging period, the more degree of freedom applied to the equation. It depends on the way researchers utilize the data for their studies. Kane and Malkiel (1976) was the first to use an autoregressive model to forecast inflation rates. However, the main purpose of this paper is to show how important it is to forecast inflation. Nakamura (2005) is another researcher that used an autoregressive model as a benchmark of her study. The study intends to find forecasting inflation of the United States. Nakamura applied up to four lagged inflation rates to the AR model. Number of lags influence

on mean square error or MSE, which used as performance indicator of the model. If MSE is small, then the model is more accurate. Although the autoregressive model is designed for linear statistics, it is used as the main forecasting technique in many countries including Thailand. Choudhary (2008) has extended his study from that of Nakamura (2005), but forecasting inflation rate for Pakistan and using a performance indicator as root mean square error (RMSE) instead of mean square error. RMSE is determined by the same method as MSE but reporting in a smaller quantity because it has been rooted out. Both Nakamura and Choudhary compared the result with Artificial Intelligence neural network, which is computer intelligence. Therefore, both researches examine efficiency differences between computer and human intelligences.

### 2.3 Artificial Neural network Approach or Computer Intelligence

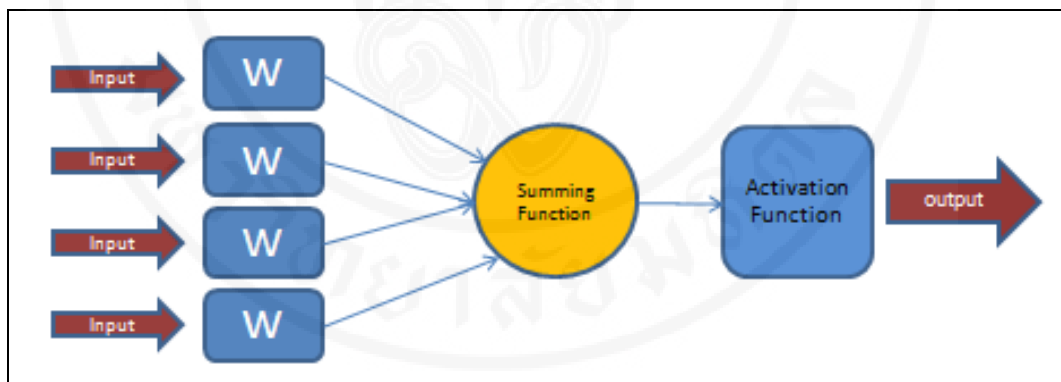

**Figure 2.1** Structure of ANN Model

*Source: Adapted by researcher*

Artificial neural network or computer intelligence is implied as the model constructed by computer intelligence, no exact formula is provided and cannot be calculated by hand or human brain. The formula is viewed as a black box for humans. According to Choudhary (2008), it works similar to the human brain, which has cognitive ability. ANN has been developed from the biological nervous system of the human brain. The process of thinking is sent via each nerve to integrated learning process, which later composes as human output or decision. ANN is also

constructed its learning process similar to human brain. Neural network received the input(s) and processed its input(s) through networks (or identical to human nerve) and presented its output after pattern recognition. However, a neural network requires many/large observation data sets for neural network training. The more it is trained, the better it captures the data pattern. Choudhary (2008) is also briefing the definition of neural network in the paper that it consists of three parts; input connection, summing (or learning) and output connection as depicted in Figure 2.1.

**Table 2.1** Types of Transfer Function

Name	Input/Output Relation	Icon	MATLAB Function
Hard Limit	$a = 0 \quad n < 0$ $a = 1 \quad n \geq 0$		hardlim
Symmetrical Hard Limit	$a = -1 \quad n < 0$ $a = +1 \quad n \geq 0$		hardlims
Linear	$a = n$		purelin
Saturating Linear	$a = 0 \quad n < 0$ $a = n \quad 0 \leq n \leq 1$ $a = 1 \quad n > 1$		satlin
Symmetric Saturating Linear	$a = -1 \quad n < -1$ $a = n \quad -1 \leq n \leq 1$ $a = 1 \quad n > 1$		satlins
Log-Sigmoid	$a = \frac{1}{1 + e^{-n}}$		logsig
Hyperbolic Tangent Sigmoid	$a = \frac{e^n - e^{-n}}{e^n + e^{-n}}$		tansig
Positive Linear	$a = 0 \quad n < 0$ $a = n \quad 0 \leq n$		poslin
Competitive	$a = 1 \quad \text{neuron with max } n$ $a = 0 \quad \text{all other neurons}$		compet

Source: *Neural network Design (Hagan, Demuth and Beale, 1995)*

### 2.3.1 Components of Neural Network

2.3.1.1 Input Connection: It can either be the same type as output or different types with output connection. Input is the information sending to the neural network and weight is adjusted according to the way researcher design the model. Total weight that distributed to each input will equal to 1.

2.3.1.2 Summing and Activation Function (transfer function):

As weight is treated as the ration of input applied to the model, summing function is a summation of the multiplication of weight with input values. Summing amount will be utilized in activation function. Activation function is the method to define transfer signals which can be log, sigmoid, linear, etc.

2.3.1.3 Output Connection: The result of the activation

process has returned the output value. This value is sent back to the beginning of network as an input value to repeat the cognitive process again.

**2.3.2 Type of Neuron Model**

According to Hagan, Demuth and Beale (1995), there are two types of neurons; single input neurons and multiple input neurons.

2.3.2.1 Single Input Neuron: As the name implies, there is

only one input to input in the model and can simply define the function as in equation 2.1 or 2.2.

$$\text{output} = f(\text{weight} * \text{input} + \text{bias}) \text{ or} \tag{2.1}$$

$$a = f(wp + b) \tag{2.2}$$

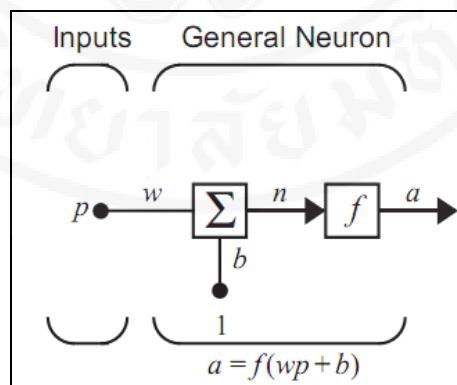

**Figure 2.2** Single Input Neuron

*Source: Neural network Design (Hagan, Demuth and Beale, 1995)*

2.3.2.2 Multiple Input Neurons – More than one inputs to

input in the model and it is standard practice to work with an artificial neural network as shown in equation 2.3, 2.4 or 2.5.

$$\text{output} = f(\text{summation of weight inputs} + \text{bias}) \text{ or} \tag{2.3}$$

$$a = f(W_p + b) \tag{2.4}$$

$$\text{Where } \mathbf{Wp} = W_{1,1}P_1 + W_{1,2}P_2 + W_{1,3}P_3 + b \quad (2.5)$$

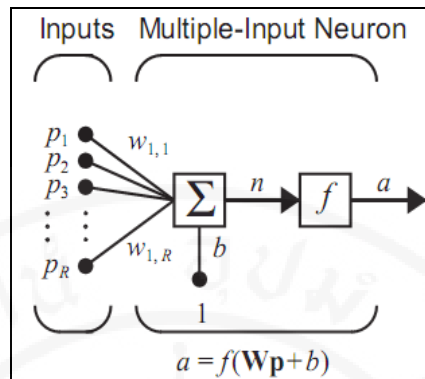

**Figure 2.3** Multiple Input Neurons

*Source: Neural network Design (Hagan, Demuth and Beale, 1995)*

### 2.3.3 Neural Network's Architecture

As the above information explains the parameter of the neural network in this section is to focus on how the neural network is operated by reference to the book written by Hagan, Demuth and Beale (1995). Neural networks can operate single task or multiple tasks at once. A task in this sense is known as “Layer” in the model. However, the more layers do not mean that the performance of the neural network will be better off than with a small number of layers or even a single layer. For example, a person working and concentrating on each task at a time might result in better outcomes than working on multi-tasks. However, if the multi-task person has skills the performance might be better and faster than the single-task person. There is also the re-check process, which improves the accuracy of the result.

2.3.3.1 Single Layer of Neuron: Only one layer of network constructs for the model and can be either one input or many inputs.

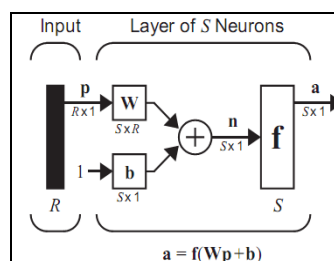

**Figure 2.4** Single Layer of Neuron

*Source: Neural network Design (Hagan, Demuth and Beale, 1995)*

2.3.3.2 Multi Layers of Neuron: More than one layer construct for the model. Figure 2.5 shows a neural network with three layers built in. In each layer weights are adjusted as well as bias applied to the summing function. The second layer is processing inputs from the output of layer one, the same practice applies to layer three and so on. However, the more layers of neuron do not mean the better learning curve of the model. Experiments are required to find out the best number of layers suitable for the model.

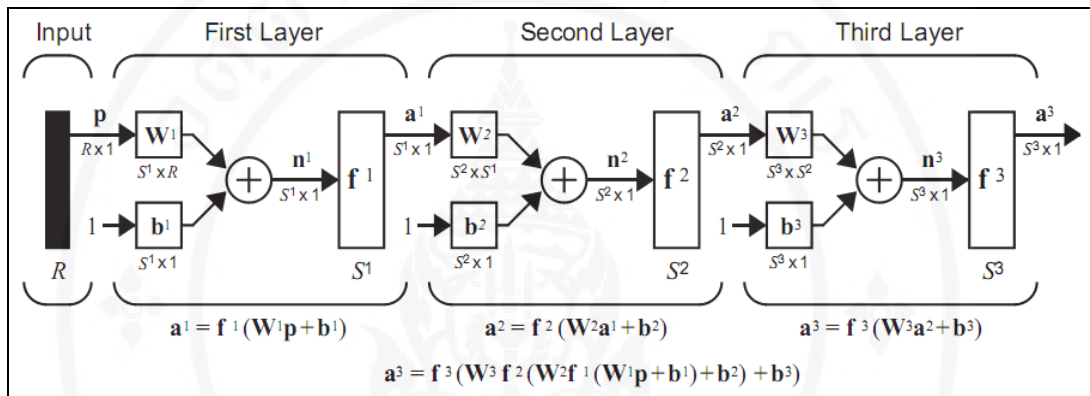

**Figure 2.5** Multi Layers of Neuron

Source: *Neural network Design (Hagan, Demuth and Beale, 1995)*

2.3.3.3 Recurrent Network: Can be either single layer or multi layer network that recursively used.

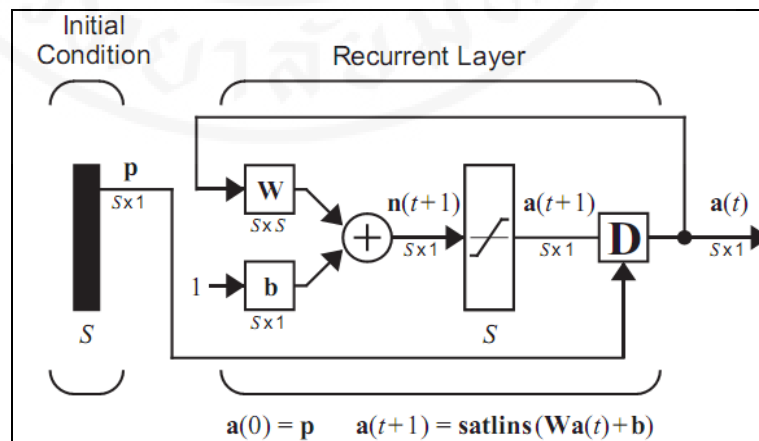

**Figure 2.6** Recurrent Network

Source: *Neural network Design (Hagan, Demuth and Beale, 1995)*

### **2.3.4 Neural Network with Macroeconomic Forecasting**

Neural network is one Artificial Intelligence that has been applied to many macroeconomic forecasting issues, such as inflation, stock, GDP and etc. It has been widely accepted by the financial industry (Trippi and Turban [1993]). The main reason for choosing neural network is because of its flexibility to recognize data patterns, especially non-linear ones (White [1989]). Many central banks in numerous countries have been using the ANN model to forecast inflation; CZECH National Bank, (Marek Hlavacek, Michael Konak and Josef Cada [2005]), Bank of Canada, (Greg Tkacz and Sarah Hu [1999]) and Bank of Jamaica, amongst others (Serju [2002]). However, the way they calculate inflation rates might not be the same as there are many types of neural network available. Moreover, the network can use either the historical data of itself to calculate its future data, or use other potential factors as inputs to find the future value of another output. For example, some papers found future inflation based on historical inflation that kept in time series (Nakamura [2005]). On the contrary, some papers might use other factors that are believed to affect the trend of inflation rates, i.e. GDP, stock price index, interest rates, wages and so forth (McNelis and McAdam [2004]).

Neural network is popular among macroeconomic forecasting in addition to inflation forecasting - this will be commented in more detail later in this paper. Srithongnopawong (2010) applied ANN to Thai stock prediction. His research brings together factors that affect the Stock Price Index of Thailand. Each factor has been tested against stationary findings the F-Statistic on the correlation of input and output of the model. The finalized factor effects are gold price, foreign exchange rate (USD/THB), Thai government bond yield, Set 50 index and Dow Jones Index. As the study picking naïve portfolios as a benchmark to ANN and using root mean square error as a performance measurement, it proved that ANN outperforms the naïve method. Another forecasting macroeconomic is over Malaysian revenue forecasting using ANN time series modeling by Shamsuddin, Sallehuddin and Yusof (2007). Instead of using other factors to predict revenue, the study involved with historical revenue to predict itself. The researcher used the data series of revenue pertaining to the back propagation type of ANN. However, the researcher has carried out preprocessing on the raw data to have range between 1 and -1. This process

allows ANN to overlook those outlier and more precise on finding revenue patterns in Malaysia. The study is measured its performance using root mean square error and transfer function or activate function as Sigmoid, Logarithmic and Siglog. The objective is to study which activation functions outperform, and it resulted in activate function Sigmoid. Therefore, there are two techniques of applying inputs into neural network model. For the using the same type of input and output to find the network, another one is using input differently from output to find the network. Neither one is right nor wrong, it depends upon the way researchers design their model.

Another popular forecasting macroeconomic using ANN is inflation starting with the study of Nakamura (2005) has shown the usefulness of neural networks over inflation forecasting based on time series data. To check out the accuracy percentage, Nakamura evaluated the result of ANN with univariate autoregression models. The paper associated ANN built out from foundation of hyperbolic tangent function with lagged inflation variables. U.S. GDP deflation is used from first quarter of 1960 to the third quarter of 2003. The observations are grouped into two sets; training and validation. A hundred initial values of randomly searched for lowest MSE using as training set, which also help out in balancing to constraints of ANN on “over-fitting” and “over-saturation”. The training algorithm employs “Levenberg- Marquardt”. Training set has specified the independent variables base on Lebaron and Weigend (1998), as two consecutive preceding periods used to estimate subsequent inflation. For example, input variables of first quarter and second quarter are formed to predict output of third quarter. The estimated equation of ANN simplified by using Hyperbolic function, but the actual practice of the paper was using non-linear function available in MATLAB toolbox. Neurodes are defined from trial and error offset the consequence by early stop procedure. As stated earlier, Nakamura evaluated the performance of ANN by comparing outcome with a simple univariate autoregression model. In conclusion, using ANN paradigm has contributed in more accurate predicted inflation than a autoregressive model. Moreover, there is an extending study of Nakamura (2005) by Haider et al. (2007). The study is forecasting Pakistan’s inflation using ANN feed forward to compare out-of-sample forecast performance of ANN with AR, which results in the same direction as Nakamura (2005).

## 2.4 Performance Measurement

To determine the performance or accuracy of the model deviation from actual value is determined as error or performance. The smaller amount deviate the better the model is. Due to many observations involved the average method on error term is required. There are many methods available to measure the error of the model, such as mean square error, root Mean square error, hit ratio etc. Mean square error or MSE is the average of error difference of predicted and actual observation square. Root mean square error or RMSE has a smaller result compared to MSE. Both methods use the same process, but one has square root the error out.

$$RMSE = \sqrt{\frac{(F_i - A_i)^2}{N}} \quad (2.6)$$

Where

<i>RMSE</i>	= Root Mean Square Error
<i>F</i>	= Forecasted Value
<i>A</i>	= Actual Value
<i>N</i>	= Numbers of Observation

## 2.5 Methodology Selected for the Study

In conclusion, this study brings together two models to evaluate forecasting performance by comparing mean square error (MSE); simple neural network model (Back Propagation Feed Forward or BPF) and autoregressive model 2 (AR(2)). Both paradigms examine different technical analysis. In addition, neural network is newly introduced and more utilize of using historical inflation to indicate future inflation. Estimated data uses Thailand's headline and core consumer pricing index in % month-on-month from year 1976 to 2009, and further finding forecasting inflation out-of-CPI resulted from the model. The research extends from Nakamura (2005) by using similar models but using a different data set. The study also contributes to the finding on how ANN can handle fluctuated inflation, i.e. headline, which includes the oil pricing index. The result is expected to have ANN perform better than AR (2).

## **CHAPTER III**

### **RESEARCH AND METHODOLOGY**

#### **3.1 Introduction**

There has been significant research on inflation forecasting using the artificial neural network (ANN). The study by Kaastra and Boyd (1995) shows that ANNs are finest tool for finding patterns of non linear events, which imitate from the ability of the human brain. The reasons that making ANN highly flexible to observe and find patterns of non-linear functions are: flexible to adapt connection processing factors, flexible to adjust independent variables for the model and efficient in finding the best model based on assembling minimum errors. Hence, a trial and error technique is used to model the inflation forecasting of this research until reaching minimum mean square error or MSE.

#### **3.2 Artificial Neural Network Selected for the Study**

A back propagation neural network is the most common type of neural network used for designing the combination of all topologies; input, hidden and output (figure 1). Input topology is holding any independent variables to contribute ANNs. Independent variables can be designed in time series prototype or they can be structured in dynamic data, such as GDP growth, consumer pricing index, oil pricing etc. Hidden layer or training layer or transfer layer processes the independent input by using training algorithms, which are presented in many functions. MATLAB has provided approximately twenty training algorithms, which each applies to different usage. For example, Lavenberg-Marquardt training algorithm is chosen by Nakamura (2005) to forecast US' inflation. Lavenberg-Marquardt sets as the default training in MATLAB, as indicated as most supervision algorithm, which adjusts weights and bias according to Lavenberg-Marquardt optimization theory. Output layer is a result of hidden layer process the independent input variable. Output data can be called a

dependent variable. Each layer contains every one of the parameters, referred to as “Neurode or Neural Node”. Numbers of neurodes on each layer does not show the performance of the neural network, i.e. the more input nodes do not mean a higher forecasting performance. As a result, many studies are using a trial and error technique until their models meet the desired mean square error.

### 3.3 Development of an Inflation Forecasting System Using an Artificial Neural Network Model

The overview of the inflation forecasting model of this study can be categorized into three divisions, as shown in the data flow diagram.

1. Preparing Data
2. Training Network
3. Predicting Inflation

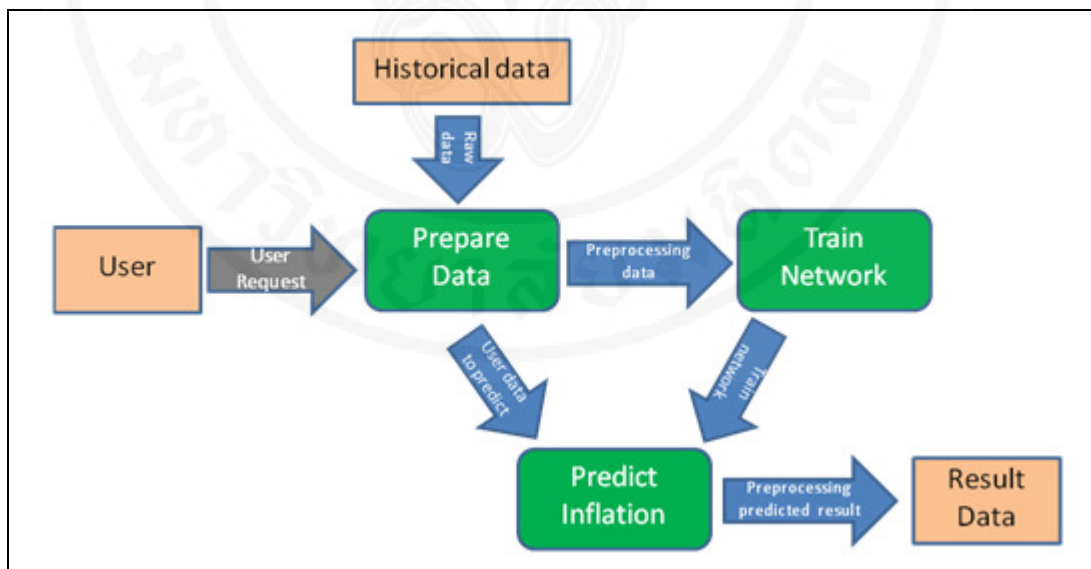

**Figure 3.1** Data Flow diagram of inflation forecasting system

*Source: Researcher's own Conceptual Model*

The diagram in figure 3.1 begins with inputting historical data to the preparation state to first process the data preprocessing. The processed data is sent to be trained in the network, varied by training algorithm. Trained data is passed to the transfer function to find the pattern of data or predicted inflation. The second process

of the diagram starts at user input inflation request to forecast. The requested data is sent to data preparation and then to the network with training algorithm. System stimulates the predict data based on user request and network algorithm.

### **3.4 Steps in Designing an ANN Inflation Forecasting Model**

#### **3.4.1 Data Preparation**

In this study, both headline and core consumer pricing indexes are selected as data sets of the ANN inflation forecasting model. They are retrieved from the Ministry of Commerce (MOC)'s official website on a monthly basis. Covering period of headline CPI is from January 1976 to December 2009. However, headline and core CPI do not have the same epoch, in which core CPI starting from January 1985 to December 2009. Both Indexes are determined from a base year of 2007 (CPI is 100). Therefore, each group of data sets (training, testing and validation) for headline and core will be varied in numbers. Two networks are built for each index, where training set is 70%, equally for testing and validation as 15% of total observations of each index type. Moreover, the inflation rate is also grouped in the same structure, which is training set 70%, testing set 15% and validation set 15%.

3.4.1.1 Headline CPI (406 Observations): training set as 285 observations out of 406 in total observations. (January 1976 to September 1999); testing set as 61 observations out of 406 in total observations (October 1999 to October 2004). Validation set as 60 observations out of 406 in total observations. (November 2004 to December 2009)

3.4.1.2 Core CPI (298 Observations): training set as 208 observations out of 298 in total observations. (January 1985 to April 2002); testing set as 45 observations out of 298 in total observations. (March 2002 to January 2006). Validation set as 45 observations out of 298 in total observations. (February 2006 to December 2009)

3.4.1.3 Headline inflation (394 observations): found from existing headline CPI, by computing percentage change of headline CPI of the same period of inflation rate month with the same month of the previous year. Therefore,

the observation sets are less than headline CPI as 12 months. Training set as 276 observations out of 394 in total observations. (January 1977 to Dec 2000); testing set as 60 observations out of 394 in total observations. (January 2001 to January 2006). Validation set as 60 observations out of 394 in total observations. (February 2006 to December 2009)

3.4.1.4 Core inflation (286 observations): found from existing core CPI, by computing percentage change of core CPI of the same period of inflation rate month with the same month of the previous year. Therefore, the observation sets are less than core CPI as 12 months. Training set as 200 observations out of 286 in total observations. (January 1986 to June 2003); testing set as 43 observations out of 286 in total observations. (July 2003 to December 2006). Validation set as 43 observations out of 286 in total observations. (January 2007 to December 2009)

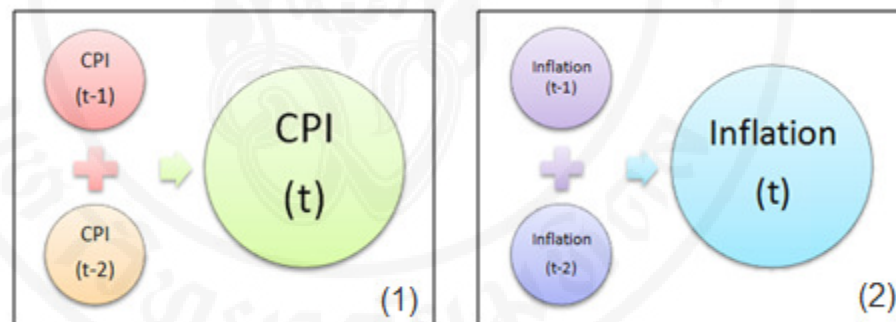

**Figure 3.2** (1) Two lagged CPI used to predict CPI (2) Two lagged inflation rate used to predict inflation rate

*Source: Adapted by Researcher*

Each observation includes two input variables and one output variable based on estimation of neural network hyperbolic tangent function from Emi Nakamura (2005). Two previous months of data inputs are used to forecast the following months of a data output as shown in Figure 8. Therefore, three consecutive months are used as inputs and output. Regarding study of Kaastra and Boyd (1996), each data set should have all observations completed, i.e. two inputs and one output are not blank. Otherwise, there are biases in the model. Since a neural network cannot present its thinking knowledge into equations, Nakamura (2005) has simply

applied the tangent function as an equation of neural network. The simple equation that illustrates the ANN model contains numbers of layers constructed in the model, weight that leverage on each layer, and also bias that contains in each layer into the equation. The equation to illustrate the neural network in the study is stated in equation 3.1. The definitions of each parameter are also explained in that there are two layers constructed in the model and each layer contains weight and lagged inflation or CPI and lastly is bias value.

$$\pi_t = L_1 * \tan h(w_1 * \pi_{t-1} + B_1) + L_2 * \tan h(w_2 * \pi_{t-2} + B_2) \quad (3.1)$$

Where

- $\pi_t$  = predicted inflation
- $L_1$  = Layer 1's weight
- $L_2$  = Layer 2's weight
- $\pi_{t-1}$  = Inflation lagged one period
- $\pi_{t-2}$  = Inflation lagged two periods
- $w_1$  = Input weight 1
- $w_2$  = Input weight 2
- $B_1$  = Bias 1
- $B_2$  = Bias 2

### 3.4.2 Preprocessing Data

This performing step helps in leveraging redundant observations. Data preprocessing is analyzing and rearranging input and output variables in a more uniform distribution. As the artificial neural network learns from patterns of data, data preprocessing would assist in minimize error, and emphasize the importance of input and output relationships. Data preprocessing employs and arranges the indexes data in Excel according to section 3.5.1

3.4.2.1 Create the fourth column and input command “=rand()” to assign random number.

3.4.2.2 Shuffle the data by sorting from random number

3.4.2.3 Graphing observation

#### 3.4.2.4 Reporting observation set

#### 3.4.2.5 Apply these data sets to ANN

### **3.4.3 Construct an Artificial Neural Network model**

Constructing neural network architecture is a very important step, since it can establish networks which sufficiently forecast inflation. The architecture of neural networks can be viewed in three aspects: number of hidden layers, number of neurons in each hidden layer, and transfer function.

3.4.3.1 Number of hidden layers: Quantity of layers has not concluded on the efficiency of the neural network. The more hidden layers are designed, the more computation time is engaged. Since the study occupies only two inputs for each observation, general recommendation will be used, which is at most two layers Kaastra and Boyd (1996).

3.4.3.2 Number of neurons in each hidden layer: approximation of number of nodes is dependent on number of input and output variables. There is a formula to estimate number of neuron for each layers of the ANN model, which is a square root of input and output multiplication. However, this study is developing neurons from MATLAB toolbox.

3.4.3.3 Transfer Function: Transfer function or activation function represents the relationship between output and input. For any non-linear and time series data like historical inflation being used in this paper sigmoid shape as transfer function is examined.

### **3.4.4 Neural Network Training**

A Levenberg-Marquardt algorithm is used for this research's ANN training. It is also a default algorithm built in MATLAB. Training data set has been prepared in step 1, is being processed. Training network is trained until result in having least MSE in excess of data validation set. Apply testing dataset to the best network obtained.

### 3.4.5 Benchmarking

An autoregressive model is used as benchmarking in comparing the results of forecasting performance from the artificial neural network. Performance is measured in terms of MSE of training dataset over validation dataset.

## 3.5 Development of Inflation Forecasting System Using an Autoregressive Model

Autoregressive (AR) model is utilized in the study as the evaluation tool for artificial neural network. Second degree order of AR manipulates is used to find forecasting inflation in time series disturbances, by using MATLAB application. Commonly it is known as autoregressive (2) with two degrees of freedom. The application is based on the equation 3.2. AR (2) has built in similar way as ANN by having two lagged periods of data to predict the current period.

$$\pi_t = C + \beta_1 \pi_{t-1} + \beta_2 \pi_{t-2} + \varphi_t \quad (3.2)$$

Where,

- $\pi_t$  = Predicted inflation
- $\pi_{t-1}$  = Lagged inflation/ CPI to one month
- $\pi_{t-2}$  = Lagged inflation/ CPI to two months
- $\beta_1$  = Slope
- $\beta_2$  = Slope
- $C$  = Intercept
- $\varphi_t$  = Error Term

## 3.6 Finding Mean Square Error

Mean Square Error (MSE) is a measurement of accuracy of the predicted value over actual value. Different types of data cannot be cross compared using MSE, since the data might be different in size. For example, data A is ranged between 100 and 200, whereas data B is ranged between 0 and 1. MSE for data A

would definitely greater than MSE of data B. The acceptable quantity of MSE depends on the researcher. The researcher could find MSE upon two different models and compare the performance or MSE. Therefore, there is no exact minimum value that researcher should define for MSE. As the name implies, it is an average of square error; the equation can then be defined as equation 3.3.

$$MSE = \frac{1}{n} \sum_{i=1}^n (F_i - A_i)^2 \quad (3.3)$$

Where

$MSE$  = Mean Square Error

$n$  = Number of validated observations

$F$  = Forecasted value

$A$  = Actual Value

$i$  = Observation  $i^{th}$

## **CHAPTER IV**

### **EMPIRICAL RESULTS**

#### **4.1 Introduction**

This section shows the results from the study using the methodology specified in chapter three. All of them are developed using a MATLAB application, which are artificial neural network and autoregressive models built up for both core and headline CPI and inflation. The results are expected to have better performance for artificial neural networks than the normal process or autoregressive (2) models. Inflation forecasting will be based on two sources; one is computed from percentage changes of forecasting CPI and the other is computed from historical inflation itself. As discussed earlier, consumer pricing index is more dynamic in terms of making use for further study such as finding inflation, defining minimum wages and so forth. Therefore, the study chooses to find both forecasting CPI and inflation. Moreover, another reason to use the consumer pricing index instead of the inflation rate is the inflation rate from CPI can be reported into more manners, such as in quarterly, monthly or annually. For example, first quarter inflation of 2010 will be calculated from a percentage change of average CPI of first quarter of 2010 and first quarter of 2009. Therefore, forecasting CPI is more dynamic than focusing directly on the inflation rate. Due to these reasons, forecasting CPI will give great benefits to the research. Therefore, this chapter categorizes empirical results into two main sections; results of implementation and interpretation of the results.

#### **4.2 Results of Implementation**

These are the results after applying the same set of CPI observations to neural network and autoregressive models (core and headline). From the developing of MATLAB program, parameters are found on the best construct of a neural network model. Core and headline are constructed differently to suit best for each

type of data. Parameters of each model are found from hundreds of iteration running of data until finding the lowest result of mean square error. For the autoregressive model, parameters are found from MATLAB by using multiple regressions. To also seal the gap of the study, ANN to forecast inflation rate is also built to compare with topologies of ANN developed for CPI forecasting. Therefore, inflation forecasting is associated from the results of CPI forecasting and forming of ANN for historical inflation. There are a total of twelve models constructed for the experiment; each has different parameters arranging for the lowest obtaining of mean square error in despite other types of ANN. To describe the design of the model, two sections are separately indicated for ANN and autoregressive.

#### **4.2.1 Parameters Defined for ANN model**

Four ANN topologies were built classified by inputted observation types obtained from the Ministry of Commerce as following:

4.2.1.1 Headline CPI

4.2.1.2 Core CPI

4.2.1.3 Headline Inflation

4.2.1.4 Core Inflation

The models are constructed per individual data type. The main setup of every topology contained seven default parameters. They are defined for each artificial neural network model, which is based on Back Propagation Feed Forward Procedure. The network is the final product of many iterated trainings until its results in lowest MSE. Defining these parameters are the most important steps and the most time consuming, since it requires a lot of trial and error looping. Even having the same set of parameters and apply to the same data set, the results of performance are different in each run. As due to neural network will adjust weight differently for the inputs of each execution, MSE will not be the same. Therefore, the network is saved once receiving lowest MSE and reported in this study. To have the same understanding each of the default parameters' definitions are explained according to the experiment.

**Default Parameter Definitions**

1. Hidden layer is the procedure operated by the network in parallel process. The study uses multiple layers as proved to have better performance.
2. Node: Each layer contains nodes, which define weight for each input and adjusted every time the model was executed.
3. Training set is fixed at 70% of total observation. The more training set is the better the network can learn the pattern of data.
4. Learning rate is the rate that controls the adjusted weight for each executable time.
5. Learning Increment/ Learning Decrement is the adjusted learning rate on iteration.
6. Training Parameter Epoch – Maximum number of trial an error each executable time. Each round of execution is set to be a thousand times. However, the real execution is not always using up the whole epoch.
7. Target MSE – Since forecasting is based on CPI and spot as 100, 0.0005 out of 100 is considered to target percentage error at 0.00005%.

**Table 4.1** Default Parameters of ANN Topologies

	<b>Headline CPI</b>	<b>Core CPI</b>	<b>Headline Inflation</b>	<b>Core Inflation</b>
<b>Hidden Layer</b>	3	3	3	3
<b>Number of Nodes for each hidden layer</b>	5	5	5	5
<b>Training Set</b>	285	210	208	200
<b>Learning Rate</b>	0.5	0.25	0.5	0.25
<b>Learning Increment/ Decrement</b>	1.2/0	1.05/0.7	1.05/0.7	1.05/0.7
<b>Training Parameter Epoch</b>	1000	1000	1000	1000
<b>Target MSE</b>	0.00005	0.00005	0.00005	0.00005

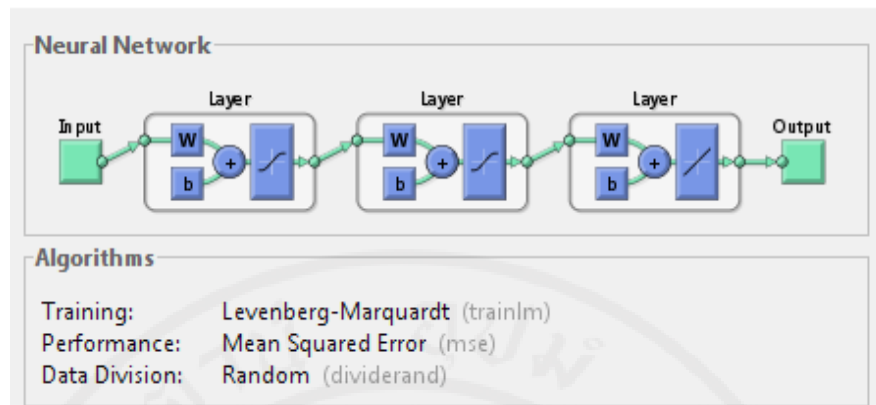

**Figure 4.1** Neural network Model

*Source: Captured from MATLAB*

The default parameters in table 4.1 are defined following the design of Choudhary (2008). However, some parameters are adjusted to obtain the smallest MSE. They are designed and trained until the network is most efficient or lowest MSE; the networks are also recorded for further reference. The network will then be applied to the validation observation (year 2008 to year 2009). If the results are highly relevant to actual values, MSE is low or equal to zero. Moreover, figure 4.1 shows the structure of the network assembles for the study. All models have three hidden layers, having training techniques as Levenberg-Marquardt, and performance measurements as mean square error (default measurement sets in MATLAB). The techniques are applied to all ANN models.

#### 4.2.2 Parameters or Coefficients Defined for Autoregressive Model

Each coefficient results from finding multiple regression of CPI lagged two periods, where each period equals one month. An autoregressive model does not require a validation set, therefore the whole observations are exercised. The result of multiple regressions contains a constant value and two coefficients. The constant value is the intercept of the point when forecasting inflation/CPI equal to constant and lagged inflation/CPI are zero. The first coefficient is set in front of the lagged one month value, and the second coefficient is set in front of the lagged two month value. They are used to adjust slope relationships between dependent and independent variables. The same practice is performed for headline and core inflation. Each equation's parameter is defined as shown in the table 4.2, in the total

of four models. They are applied to the equation indicated in Chapter 3 and brought to display here (equation 4.1). The mean square in figure 4.1 is not having the same objective as the mean square finding on the performance. It is the averaging of error when the system is trying to construct a multiple linear line. The line might not precisely touch the actual data, although it is constructed for the best angle to pass thru the observation set the most.

$$\pi_t = C + \beta_1\pi_{t-1} + \beta_2\pi_{t-2} + \varphi_t \tag{4.1}$$

**Table 4.2** Autoregressive (2) Parameters

	<b>Headline CPI</b>	<b>Core CPI</b>	<b>Headline Inflation</b>	<b>Core Inflation</b>
<b>Constant (C)</b>	0.1675	0.1897	0.1150	0.0423
<b><math>\beta_1</math></b>	-0.2356	-0.2973	-0.1680	-0.2100
<b><math>\beta_2</math></b>	1.2353	1.2968	1.1453	1.1942
<b>Mean square of <math>\varphi_t</math></b>	0.0846	0.0484	0.6315	0.1906

### 4.3 Interpretation of Results

After constructing each model using parameter sets defining in section 4.2, the differences between forecasting value and actual value as a mean squared error (MSE) are found according to the steps indicated in Chapter 3. The summary of the twelve constructed models are shown in table 4.3. It shows four MSE values measure the performance of CPI forecasting and eight MSE values measure the performance of inflation forecasting. The size of MSE cannot be crossed comparing, i.e. MSE results from forecasting CPI cannot use to compare the performance of forecasting inflation, as it resulted in a different unit. CPI ranges from 20 to 105 whereas inflation ranges between -2 to 5. Therefore, the explanation and analysis are extended into two sections; performance of forecasting CPI and performance of forecasting inflation as our main purpose of study. Yet, the performance of forecasting CPI does affect the analysis of inflation as it has a mutual relationship;

the consequent of forecasting CPI will be used. The period of validating the result of measurement is two years, Jan 2008 to December 2009. During this period, global recession effect became established. The inflation rate dramatically dropped and went gradually up after government policy aimed at boosting spending. The actual value of CPI and inflation are diverging. As a consequence, choosing these two years to validate the result of model is very uncertain. Since there is no exact trend which encourages the experiment to measure all methodologies to find out which one has the most relevant products.

**Table 4.3** Performance summary of twelve models

	Forecasting CPI		Forecasting Inflation			
	ANN	AR(2)	ANN (CPI)	AR(2) (CPI)	ANN (Inflation)	AR(2) (Inflation)
<b>Headline</b>	1.12	1.14	1.83	1.81	2.71	2.98
<b>Core</b>	0.25	1.07	0.60	1.14	0.62	0.37

#### 4.3.1 Performance of CPI forecasting

As shown in the table 4.3, accomplishment of an artificial neural network has enhanced performance in terms of MSE for headline and core CPIs forecasting. ANN Headline CPI is 0.02 units greater than autoregressive (2) on the same type of data. However, ANN of Core CPI has proved to have great deviation from autoregressive (2) as 0.82 units. Therefore, ANN model has substantiated outstanding performance of finding forecasting CPI for all types of CPI reserved in Thailand. However, headline CPI has shown poorer performance than core CPI due to numerous factors. Headline CPI is more fluctuated than core CPI as it included the oil price index and raw food index to the calculation. Moreover, there was an economic recession in 2008 to trigger the fluctuating of CPI and inflation. According to figure 4.2 shows the summary of factor effects on its adjustment, Headline CPI correlates to economic recession, the oil price index and the raw food index where core CPI is affected by economic recession only. According to the Ministry of Energy website, oil prices rose highest in history in 2008 and gradually decreased in consecutive years. It shows that a consumer pricing index that includes oil prices

would absolutely oscillate. Consequently, the result of performance measurement on headline is lower than core CPI over the same method.

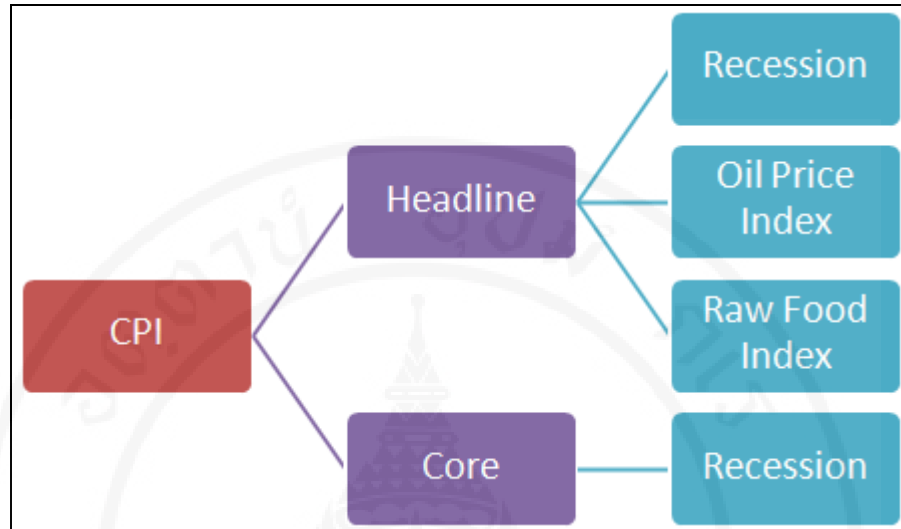
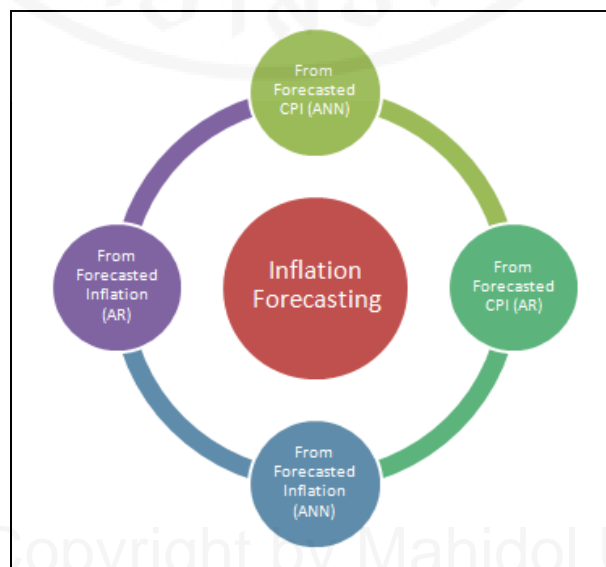

**Figure 4.2** Factor effects of instable CPI

*Source: Adapted by Researcher*

### 4.3.2 Performance of Inflation Forecasting

As already mentioned, validation sets from year 2008 to 2009 occur during economic recession contains instability information. To predict any macroeconomic values during this period is very challenging. Therefore, the study has analyzed the inflation forecasting in four ways to find the best performance (Figure 4.3):



**Figure 4.3** Methodologies constructed for inflation forecasting

*Source: Adapted by Researcher*

1. Using forecasted CPI that executed from artificial neural network to find forecasting inflation by finding percentage change of CPI.
2. Using forecasted CPI that executed from an autoregressive model to find forecasting inflation by finding percentage change of CPI.
3. Using historical inflation to apply to an artificial neural network to find forecasting inflation rate.
4. Using historical inflation to apply to Autoregressive (2) to find forecasting inflation rate.

**Table 4.4** Performance on Forecasting Inflation

	<b>ANN (CPI)</b>	<b>ANN (Inflation)</b>	<b>AR(2) (CPI)</b>	<b>AR(2) (Inflation)</b>
<b>Headline Inflation</b>	1.81	2.71	1.83	2.98
<b>Core Inflation</b>	0.60	0.623	1.14	0.37

Artificial neural network of CPI has proved to have the best performance among the methods to forecast headline inflation. Whereas, core inflation rates have proved that AR (2) constructed from historical inflation has lowest MSE. However, MSE on forecasting headline inflation has greater deviation than core inflation on implementation of ANN models. The performance of an autoregressive model on predicting headline inflation is similar to the ANN of CPI to forecast headline inflation. However, the performance of ANN for core inflation predicting is far better than the autoregressive model. In conclusion, an artificial neural network has been proven to have higher performance than the autoregressive model for both CPI and inflation.

## **CHAPTER V**

### **CONCLUSION**

#### **5.1 Introduction**

From the beginning of the research this author has had the objective to build an artificial neural network model to forecast the inflation rate of Thailand. The autoregressive model is another that builds against the ANN to compare performance, which measures in mean square error unit. The second chapter has provided the background and previous research that seeks to find the most accurate future macroeconomic data, especially inflation rates. The study has brought those previous researches to apply in this study to seek out if ANN model is suitable to forecast the Thai inflation rate or not. The results of all scenarios from this research are shown in matrix form in Chapter four. Thus, the final chapter aims to provide a summary of the research, explain the limitations of analysis and last but not least make suggestions for further study.

#### **5.2 Research Conclusion**

Computer intelligence systems have been included in this research to compare effectiveness with statistical intelligence. Artificial neural network is the computer intelligence methodology selected to find the estimation of Thai inflation. For the statistical intelligence an autoregressive model with time series was selected. The supports of design and parameters defined are stated in chapters two and three which were established based on previous research and own adjustment until reaching the most accurate results or lowest MSE. Artificial neural network has a working capability similar to the human brain. The “brain” of ANN is called a “Network”. The network has been trained from historical time series of CPI and inflation until it starts to pick up the pattern of these statistics. Whereas, the autoregressive model is finding the line that passes close to data the most. It

constructs the same in both models, by having two previous periods of data of consecutive inflation or CPI rates. There are twelve models in total that were designed from different sorts of data, i.e. core/ headline CPI and core/headline inflation, and their performance results are shown in the table 5.1.

**Table 5.1** Performance summary of twelve models

	Forecasting CPI		Forecasting Inflation			
	ANN	AR(2)	ANN (CPI)	AR(2) (CPI)	ANN (Inflation)	AR(2) (Inflation)
<b>Headline</b>	1.12	1.14	1.83	1.81	2.71	2.98
<b>Core</b>	0.25	1.07	0.60	1.14	0.62	0.37

Headline and core consumer pricing indices are formally accounted for inflation computation of Thailand. The same method of computation is used on the headline and core CPI, where the main differences are the price of oil and raw food. Headline CPI includes groups of fluctuating data, which is more diverging month by month. On the contrary, core CPI excludes them and is often used for news reporting. The main reason that the study uses both types of CPI to build the model is to find if ANN model is applicable for very fluctuating statistics like headline CPI or not. The outcomes of the experiment show ANN has a better performance than the autoregressive on forecasting headline CPI and inflation and core CPI and inflation. Nevertheless, headline has not proved to have outstanding performance by using ANN. There are three factors affecting the influence of the learning process of ANN: economic recession, the oil price index and the raw food index. The majority of Thai exports are to the United States. The US originated the global recession and the situation caused the income flow system to be trapped. Moreover, oil prices had reached their highest in 2008 from the stability of oil prices. These two main factors caused the difficulty with the ANN model to find the trend. Therefore, the performance of ANN to forecast headline CPI and inflation are about the same as using an autoregressive model.

On the contrary, forecasting core CPI and Inflation from building ANN model has an outstanding result over the autoregressive model. The study experimented with inflation forecasting using forecasted CPI as well as forecasting

inflation based on historical time series of inflation itself. Even though the economic recession occurred from 2008 to 2009, the performance of the model was deemed to be excellent. Since there are two ANN models used to forecast core inflation, the ANN model form to forecast core CPI (and then used to find forecasting inflation) has a slightly higher performance than the ANN model form to forecast core inflation. However, by forecasting core CPI first and then using the value to forecast core inflation is more flexible in any further adjustment. Therefore, there would be no doubt that ANN gives a better performance to the forecasting of inflation, as it is the main factor to drive economic policies and show the country monetary direction. If predicted inflation will be surge in the next two months, the government or policy makers can in time issue strategy to deal with the economic situation. The study has demonstrated that ANN is applicable to forecast inflation rates of Thailand by either CPI or inflation.

### **5.3 Limitation of Analysis**

The limitations during the study which reduced efficiency in predicting inflation rates were in the validation period. The study happened to be during the present economic recession period, thus validation periods fluctuate inflation and consumer pricing index. Therefore, the experimental results are causing mean square error to be higher than in a more stable period.

### **5.4 Further Research**

The author's current study is associated with only inflation or consumer pricing index to predict their forecasting statistics. Therefore, the suggestion of continuous study would be to gather and study other factors that cause changes in inflation rates and consumer pricing index. The researcher needs to study if those factors have a relationship to inflation or CPI. Moreover, to be able to fully make use of each factor, stationary testing is required for the most accurate result of the model. Results may be better or worse depending on the design of the ANN employed in the research.

## REFERENCES

- Choudhary, A. (2008). Neural Network Models for Inflation Forecasting. *IEEE Transactions on Neural Networks*, 12, 674-683.
- Enders, W. (2003), *Applied Econometric Time Series, 2nd Edition*. United States: Wiley.
- Fujiwara, I. and Koga, M. (2002). A Statistical Forecasting Method for Inflation Forecasting, *Working Paper Series* (02-5).
- Hagan, M., Demuth, H. and Beale, M. (1995). *Neural Network Design*. United States: PWS Publishing Company.
- Hamilton, J.D. (1995). *Time Series Analysis*. United States: Princeton University Press.
- Kaastra, I. and Boyd, M. (1995). Designing a Neural Network for Forecasting Financial and Economic Time 1. *Neurocomputing ELSEVIER Neurocomputing 10* (1996), 215-236.
- Kane, E.J. and Malkiel, B.G. (1976). Autoregressive and Nonautoregressive Elements in Cross-Section Forecasts of Inflation. *Econometrica*, 44, 1.
- Koop, G. and Korobilis, D. (2009). Forecasting Inflation using Dynamic Model Averaging. *Working Paper Series – personal.strath.ac.uk*.
- Lebaron, B. and Weigend, A.S. (1998). A Bootstrap Evaluation of the Effect of Data Splitting on Financial Time Series. *IEEE Transactiontions on Neural Networks*, 9 (1), 213-220.
- Moshiri, S. and Cameron, N. (2000). Econometrics Versus ANN Models in Forecasting Inflation. *Journal of Forecasting*, 19, 201-217.
- Nakamura, E. (2005). Inflation Forecasting using a Neural Network. *Economics Letters* (86-3), 373-378.
- Shamsuddin, S.M., Sallehuddin, R. and Yusof, N.M. (2007). Artificial Neural Network Time Series Modeling for Revenue Forecasting. *Chiang Mai Journal Science*, 35(3), 411-426.

- Srithongnopawong, P. (2007). Using Relative Movement to Support ANN-based Stock Forecasting in Thai Stock Market. *International Journal of Electronic Finance* (4), 84-98.
- Thawornwong, S. and Enke, D. (2004). The Adaptive Selection of Financial and Economic Variables for Use with Artificial Neural Networks. *Neurocomputing*, 56 (2004), 205-232.

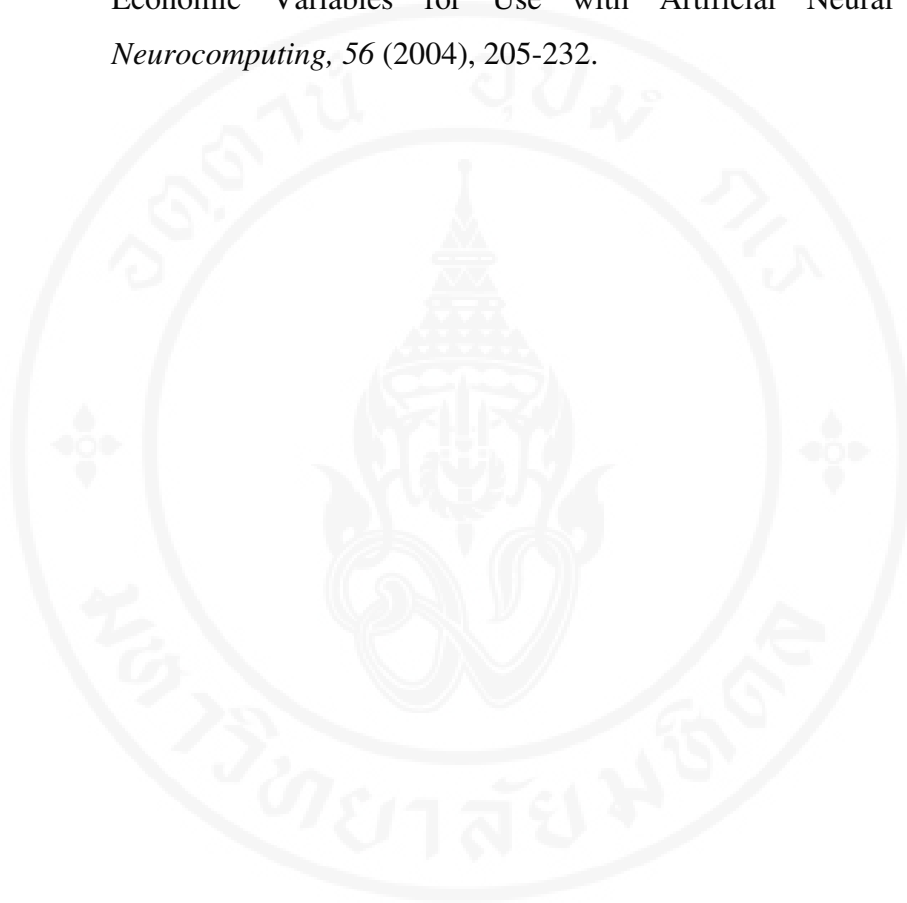



**APPENDICES**

**APPENDIX A****Results of Core Inflation Forecasting based on forecasting of CPI using ANN during year 2008 to 2009**

<b>Month</b>	<b>Actual CPI</b>	<b>Actual Inflation</b>	<b>Forecasted CPI using ANN</b>	<b>CPI Error Square</b>	<b>Forecasted Inflation base on Forecasted CPI using ANN</b>	<b>Inflation Error Squared</b>
<b>Jan-08</b>	100.80	1.31	101.17	0.14	1.15	0.03
<b>Feb-08</b>	101.00	1.51	101.25	0.06	1.10	0.17
<b>Mar-08</b>	101.30	1.71	101.40	0.01	1.28	0.19
<b>Apr-08</b>	101.90	2.10	101.61	0.09	1.36	0.56
<b>May-08</b>	102.60	2.81	101.96	0.41	1.50	1.70
<b>Jun-08</b>	103.50	3.60	102.28	1.50	1.86	3.03
<b>Jul-08</b>	103.70	3.70	102.58	1.26	2.05	2.74
<b>Aug-08</b>	102.70	2.70	102.66	0.00	2.04	0.44
<b>Sep-08</b>	102.70	2.50	102.24	0.22	1.64	0.73
<b>Oct-08</b>	102.80	2.29	102.30	0.25	1.49	0.63
<b>Nov-08</b>	102.60	1.99	102.35	0.06	1.28	0.50
<b>Dec-08</b>	102.50	1.79	102.25	0.06	1.14	0.42
<b>Jan-09</b>	102.40	1.59	102.21	0.04	1.03	0.31
<b>Feb-09</b>	102.80	1.78	102.17	0.40	0.91	0.76
<b>Mar-09</b>	102.80	1.48	102.35	0.20	0.94	0.29
<b>Apr-09</b>	102.90	0.98	102.34	0.31	0.73	0.06
<b>May-09</b>	102.30	-0.29	102.39	0.01	0.42	0.50
<b>Jun-09</b>	102.50	-0.97	102.08	0.18	-0.19	0.60
<b>Jul-09</b>	102.50	-1.16	102.23	0.08	-0.34	0.67
<b>Aug-09</b>	102.50	-0.19	102.22	0.08	-0.43	0.06
<b>Sep-09</b>	102.60	-0.10	102.22	0.15	-0.02	0.01
<b>Oct-09</b>	102.70	-0.10	102.27	0.19	-0.04	0.00
<b>Nov-09</b>	102.70	0.10	102.31	0.15	-0.04	0.02
<b>Dec-09</b>	102.80	0.29	102.30	0.25	0.05	0.06
<b>MSE</b>				<b>0.25</b>		<b>0.60</b>

## APPENDIX B

### Results of Core CPI Forecasting during year 2008 to 2009

Month	Actual CPI	Actual Inflation	Forecasted CPI using AR Bo = 0.1897 B1 = -0.2973 B2 = 1.2968		Forecasted Inflation base on Forecasted CPI using AR	
			CPI	Error Square	Inflation Error Squared	Inflation Error Squared
<b>Jan-08</b>	100.80	1.31	101.18	0.15	1.55	0.06
<b>Feb-08</b>	101.00	1.51	101.51	0.26	1.75	0.06
<b>Mar-08</b>	101.30	1.71	102.18	0.77	2.19	0.24
<b>Apr-08</b>	101.90	2.10	102.90	1.00	2.97	0.74
<b>May-08</b>	102.60	2.81	103.85	1.56	3.79	0.96
<b>Jun-08</b>	103.50	3.60	103.88	0.15	3.72	0.01
<b>Jul-08</b>	103.70	3.70	102.60	1.21	2.46	1.54
<b>Aug-08</b>	102.70	2.70	102.84	0.02	2.44	0.07
<b>Sep-08</b>	102.70	2.50	102.96	0.07	2.24	0.07
<b>Oct-08</b>	102.80	2.29	102.69	0.01	1.91	0.14
<b>Nov-08</b>	102.60	1.99	102.61	0.00	1.74	0.06
<b>Dec-08</b>	102.50	1.79	102.51	0.00	1.54	0.06
<b>Jan-09</b>	102.40	1.59	103.03	0.40	1.82	0.06
<b>Feb-09</b>	102.80	1.78	102.94	0.02	1.41	0.14
<b>Mar-09</b>	102.80	1.48	103.06	0.07	0.86	0.38
<b>Apr-09</b>	102.90	0.98	102.30	0.37	-0.59	2.47
<b>May-09</b>	102.30	-0.29	102.68	0.15	-1.12	0.69
<b>Jun-09</b>	102.50	-0.97	102.64	0.02	-1.20	0.05
<b>Jul-09</b>	102.50	-1.16	102.64	0.02	0.03	1.42
<b>Aug-09</b>	102.50	-0.19	102.76	0.07	-0.07	0.01
<b>Sep-09</b>	102.60	-0.10	102.86	0.07	-0.10	0.00
<b>Oct-09</b>	102.70	-0.10	102.84	0.02	0.14	0.06
<b>Nov-09</b>	102.70	0.10	105.68	8.90	2.99	8.38
<b>Dec-09</b>	102.80	0.29	106.01	10.28	3.41	9.70
<b>MSE</b>				<b>1.07</b>		<b>1.14</b>

**APPENDIX C****Results of Core Inflation Forecasting during year 2008 to 2009**

<b>Month</b>	<b>Actual CPI</b>	<b>Actual Inflation</b>	<b>Forecasted Inflation using ANN</b>		<b>Forecasted Inflation using AR</b>	
			<b>on Historical Inflation</b>	<b>Inflation Error Square</b>	<b>Bo =0.0423 B1 = -0.2100 B2 =1.1942</b>	<b>Inflation Error Squared</b>
<b>Jan-08</b>	100.80	1.31	1.48	0.03	1.57	0.07
<b>Feb-08</b>	101.00	1.51	1.96	0.21	1.76	0.07
<b>Mar-08</b>	101.30	1.71	2.08	0.14	2.20	0.24
<b>Apr-08</b>	101.90	2.10	2.73	0.39	2.95	0.72
<b>May-08</b>	102.60	2.81	3.31	0.26	3.76	0.90
<b>Jun-08</b>	103.50	3.60	3.58	0.00	3.70	0.01
<b>Jul-08</b>	103.70	3.70	2.53	1.38	2.49	1.46
<b>Aug-08</b>	102.70	2.70	2.43	0.07	2.45	0.06
<b>Sep-08</b>	102.70	2.50	2.21	0.08	2.25	0.06
<b>Oct-08</b>	102.80	2.29	1.90	0.15	1.94	0.12
<b>Nov-08</b>	102.60	1.99	1.68	0.09	1.76	0.05
<b>Dec-08</b>	102.50	1.79	1.48	0.09	1.56	0.05
<b>Jan-09</b>	102.40	1.59	1.73	0.02	1.84	0.06
<b>Feb-09</b>	102.80	1.78	1.36	0.17	1.44	0.12
<b>Mar-09</b>	102.80	1.48	0.84	0.42	0.90	0.33
<b>Apr-09</b>	102.90	0.98	-0.59	2.48	-0.51	2.23
<b>May-09</b>	102.30	-0.29	-0.81	0.27	-1.05	0.57
<b>Jun-09</b>	102.50	-0.97	-0.89	0.01	-1.14	0.03
<b>Jul-09</b>	102.50	-1.16	-0.43	0.53	0.05	1.46
<b>Aug-09</b>	102.50	-0.19	-0.13	0.00	-0.03	0.03
<b>Sep-09</b>	102.60	-0.10	-0.14	0.00	-0.05	0.00
<b>Oct-09</b>	102.70	-0.10	-0.10	0.00	0.18	0.08
<b>Nov-09</b>	102.70	0.10	2.33	4.99	0.37	0.08
<b>Dec-09</b>	102.80	0.29	2.11	3.31	0.10	0.04
<b>MSE</b>				<b>0.63</b>		<b>0.37</b>

**APPENDIX D****Results of Headline Inflation Forecasting based on forecasting of CPI using ANN during year 2008 to 2009**

<b>Month</b>	<b>Actual CPI</b>	<b>Actual Inflation</b>	<b>Forecasted CPI using ANN</b>	<b>CPI Error Square</b>	<b>Forecasted Inflation base on Forecasted CPI using ANN</b>	<b>Inflation Error Squared</b>
<b>Jan-08</b>	102.50	4.27	101.88	0.39	3.16	1.23
<b>Feb-08</b>	103.20	5.41	102.70	0.25	4.21	1.44
<b>Mar-08</b>	103.80	5.38	103.33	0.22	5.31	0.01
<b>Apr-08</b>	105.60	6.13	103.86	3.02	5.09	1.08
<b>May-08</b>	107.90	7.58	105.55	5.50	5.70	3.51
<b>Jun-08</b>	109.10	8.77	107.50	2.56	6.84	3.72
<b>Jul-08</b>	109.50	9.17	108.35	1.33	7.78	1.95
<b>Aug-08</b>	106.20	6.52	108.58	5.69	8.01	2.23
<b>Sep-08</b>	106.40	6.08	105.59	0.66	5.71	0.14
<b>Oct-08</b>	105.10	3.85	106.08	0.97	5.46	2.57
<b>Nov-08</b>	103.80	2.17	104.83	1.06	3.29	1.27
<b>Dec-08</b>	102.10	0.39	103.67	2.47	1.83	2.05
<b>Jan-09</b>	102.10	-0.39	102.07	0.00	0.19	0.33
<b>Feb-09</b>	103.10	-0.10	102.24	0.74	-0.44	0.12
<b>Mar-09</b>	103.60	-0.19	103.27	0.11	-0.06	0.02
<b>Apr-09</b>	104.60	-0.95	103.67	0.86	-0.18	0.58
<b>May-09</b>	104.30	-3.34	104.61	0.10	-0.89	5.97
<b>Jun-09</b>	104.70	-4.03	104.22	0.23	-3.05	0.96
<b>Jul-09</b>	104.70	-4.38	104.64	0.00	-3.42	0.93
<b>Aug-09</b>	105.10	-1.04	104.60	0.25	-3.67	6.93
<b>Sep-09</b>	105.30	-1.03	104.99	0.10	-0.57	0.22
<b>Oct-09</b>	105.50	0.38	105.15	0.13	-0.88	1.60
<b>Nov-09</b>	105.80	1.93	105.32	0.23	0.47	2.13
<b>Dec-09</b>	105.70	3.53	105.58	0.01	1.84	2.83
<b>MSE</b>				<b>1.12</b>		<b>1.83</b>

**APPENDIX E****Results of Headline CPI Forecasting during year 2008 to 2009**

Month	Actual CPI	Actual Inflation	Forecasted CPI using AR		Forecasted Inflation base on	
			Bo = 0.1675 B1 = -0.2356 B2 = 1.2353	CPI Error Square	Forecasted CPI using AR	Inflation Error Squared
<b>Jan-08</b>	102.50	4.27	101.86	0.41	3.29	0.96
<b>Feb-08</b>	103.20	5.41	102.83	0.14	4.51	0.82
<b>Mar-08</b>	103.80	5.38	103.50	0.09	5.67	0.09
<b>Apr-08</b>	105.60	6.13	104.08	2.32	5.36	0.59
<b>May-08</b>	107.90	7.58	106.16	3.03	6.29	1.65
<b>Jun-08</b>	109.10	8.77	108.58	0.27	7.90	0.76
<b>Jul-08</b>	109.50	9.17	109.52	0.00	9.04	0.02
<b>Aug-08</b>	106.20	6.52	109.73	12.45	9.25	7.46
<b>Sep-08</b>	106.40	6.08	105.56	0.71	5.88	0.04
<b>Oct-08</b>	105.10	3.85	106.58	2.20	5.97	4.48
<b>Nov-08</b>	103.80	2.17	104.93	1.28	3.33	1.35
<b>Dec-08</b>	102.10	0.39	103.63	2.34	1.77	1.89
<b>Jan-09</b>	102.10	-0.39	101.84	0.07	-0.02	0.13
<b>Feb-09</b>	103.10	-0.10	102.24	0.74	-0.57	0.23
<b>Mar-09</b>	103.60	-0.19	103.47	0.02	-0.03	0.03
<b>Apr-09</b>	104.60	-0.95	103.85	0.56	-0.21	0.54
<b>May-09</b>	104.30	-3.34	104.97	0.45	-1.12	4.92
<b>Jun-09</b>	104.70	-4.03	104.37	0.11	-3.88	0.02
<b>Jul-09</b>	104.70	-4.38	104.93	0.05	-4.19	0.04
<b>Aug-09</b>	105.10	-1.04	104.84	0.07	-4.46	11.72
<b>Sep-09</b>	105.30	-1.03	105.33	0.00	-0.22	0.67
<b>Oct-09</b>	105.50	0.38	105.48	0.00	-1.03	1.99
<b>Nov-09</b>	105.80	1.93	105.68	0.01	0.72	1.46
<b>Dec-09</b>	105.70	3.53	106.01	0.09	2.29	1.52
<b>MSE</b>				<b>1.14</b>		<b>1.81</b>

## APPENDIX F

### Results of Headline Inflation Forecasting during year 2008 to 2009

Month	Actual CPI	Actual Inflation	Forecasted Inflation		Forecasted Inflation using AR	
			using ANN on Historical Inflation	Inflation Error Square	Bo =0.1150 B1 = -0.1680 B2 = 1.1453	Inflation Error Squared
<b>Jan-08</b>	102.50	4.27	5.68	1.99	5.60	1.76
<b>Feb-08</b>	103.20	5.41	5.49	0.01	5.37	0.00
<b>Mar-08</b>	103.80	5.38	6.30	0.84	6.23	0.73
<b>Apr-08</b>	105.60	6.13	7.81	2.82	7.76	2.67
<b>May-08</b>	107.90	7.58	8.91	1.79	8.89	1.72
<b>Jun-08</b>	109.10	8.77	9.12	0.12	9.15	0.14
<b>Jul-08</b>	109.50	9.17	6.06	9.69	6.04	9.81
<b>Aug-08</b>	106.20	6.52	6.06	0.21	5.99	0.29
<b>Sep-08</b>	106.40	6.08	3.82	5.13	3.51	6.63
<b>Oct-08</b>	105.10	3.85	2.23	2.65	1.95	3.63
<b>Nov-08</b>	103.80	2.17	0.55	2.61	0.20	3.86
<b>Dec-08</b>	102.10	0.39	-0.01	0.16	-0.40	0.63
<b>Jan-09</b>	102.10	-0.39	0.28	0.44	0.07	0.21
<b>Feb-09</b>	103.10	-0.10	0.18	0.08	-0.09	0.00
<b>Mar-09</b>	103.60	-0.19	-0.39	0.04	-0.94	0.55
<b>Apr-09</b>	104.60	-0.95	-1.34	0.16	-3.55	6.76
<b>May-09</b>	104.30	-3.34	-1.40	3.75	-3.94	0.37
<b>Jun-09</b>	104.70	-4.03	-1.42	6.85	-4.23	0.04
<b>Jul-09</b>	104.70	-4.38	-0.25	17.10	-0.33	16.39
<b>Aug-09</b>	105.10	-1.04	-0.41	0.39	-0.90	0.02
<b>Sep-09</b>	105.30	-1.03	0.75	3.19	0.72	3.09
<b>Oct-09</b>	105.50	0.38	2.27	3.56	2.26	3.52
<b>Nov-09</b>	105.80	1.93	1.27	0.43	3.83	3.62
<b>Dec-09</b>	105.70	3.53	2.57	0.92	1.29	4.98
<b>MSE</b>				<b>2.70</b>		<b>2.98</b>

## BIOGRAPHY

**NAME** Ladawan Khongdamnern

**DATE OF BIRTH** 21 July 1982

**PLACE OF BIRTH** Songkhla, Thailand

**INSTITUTION ATTENDED** Mahidol University, 2002 – 2006  
Bachelor of Science (Computer)

Mahidol University, 2008 – 2010  
Master of Business Administration  
(Business Modeling)

**HOME ADDRESS** 857/ 15 Sukhumvit 101 Rd.  
Bangchak Prakhanong  
Bangkok, Thailand 10260  
E-mail: [ladawank@gmail.com](mailto:ladawank@gmail.com)

**EMPLOYEE ADDRESS** ExxonMobil Ltd.  
54 Sathorn Rd.  
Bangrak Bangkok, Thailand  
E-mail: [th-lms@exxonmobil.com](mailto:th-lms@exxonmobil.com)